

TECHNICAL MANUAL

**OPERATOR'S AND UNIT MAINTENANCE MANUAL
(INCLUDING REPAIR PARTS AND SPECIAL TOOLS LISTS)**

**SPACE HEATER, CONVECTIVE
NSN 4520-01-431-8927**



DISTRIBUTION STATEMENT A – Approved for public release; distribution is unlimited.

**HEADQUARTERS, DEPARTMENT OF THE ARMY
29 JANUARY 2002**

WARNING SUMMARY

This warning summary contains general safety warnings and hazardous materials warnings that must be understood and applied during operation of this equipment. Failure to observe these precautions could result in serious injury or death to personnel. Also included are explanations of safety and hazardous materials icons used within this technical manual. Refer to FM 4-25.11 for all first aid needs.

EXPLANATION OF SAFETY WARNING ICONS



ELECTRICAL - electrical wire to arm with electricity symbol running through human body shows that shock hazard is present.



HEAVY OBJECT – human figure stooping over heavy object shows physical injury potential from improper lifting technique.



CARBON MONOXIDE – human figure showing gaseous substance being inhaled into respiratory system, demonstrating potential hazard.



EXPLOSION - rapidly expanding symbol shows that the material may explode if subjected to high temperatures, sources of ignition, or high pressure.



FIRE - flame shows that a material may ignite and cause burns.



HOT AREA - hand over object radiating heat shows that part is hot and can burn.



CRYOGENIC - hand in block of ice shows that the material is extremely cold and can injure human skin or tissue.



CHEMICAL - drops of liquid on hand shows that the material will cause burns or irritation to human skin or tissue.



POISON - skull and crossbones shows that a material is poisonous or is a danger to life.



SHARP OBJECT - pointed object in hand shows that a sharp object presents a danger to limb.

GENERAL SAFETY WARNINGS DESCRIPTION



WARNING

Carbon monoxide is without color or smell, but can kill you. Breathing carbon monoxide produces symptoms of headache, dizziness, loss of muscular control, a sleepy feeling, unconsciousness, or coma. Brain damage or death can result from heavy exposure. Carbon monoxide is present in the exhaust of any fuel-burning heater and internal combustion engines. Dangerous levels of carbon monoxide will occur from operating the Space Heater, Convective in an enclosed area.

Precautions must be followed to ensure operator's safety when the Space Heater, Convective is in operation.

- DO NOT operate Space Heater, Convective in an enclosed area.
- Direct the Space Heater, Convective exhaust outlet away from shelters or personnel.
- BE ALERT at all times during operating procedures for carbon monoxide poisoning. If symptoms are present, IMMEDIATELY evacuate personnel and seek medical attention.
- BE AWARE the field protection mask used for nuclear-biological-chemical attack WILL NOT protect you from carbon monoxide poisoning.

The best defense against Carbon Monoxide poisoning is good ventilation.



WARNING

Do not touch extremely cold metal parts with bare hands. Flesh may stick to extremely cold metal parts. Frostbite can cause permanent injury to personnel.



WARNING



Fuels are toxic and flammable. Do not refuel near open flame or other ignition sources. Only refuel in a well-ventilated area. Wear protective goggles, avoiding contact with skin and clothes, and don't breathe vapors. If contact with eyes or skin is made, immediately flush with clean water and get medical first aid for eyes immediately.



WARNING

The Space Heater Convective weighs approximately 74 pounds (33.6 kg) without accessories. Two persons must carry the unit, lifting with your legs, not your back, to prevent injury. Failure to do so may result in serious back or other musculo-skeletal injuries.



WARNING

Do not remove the heater assembly while any of the advisory lights are lit.

Small, portable, shelter heaters of this type are not designed to be moved during operation or before purge cycles are complete. Serious injury, burns, or death can occur if the heater assembly is moved while operating or before the HEATER ON/ON-HOLD advisory light goes OFF indicating the end of operation, post purge, and cool down cycle completion.

During operation some metal components of the heater assembly become extremely hot, such as the louver on the outlet duct, and the upper and lower heater housing assemblies. Contact with bare skin can cause severe burn injuries.

During heater operation, air leaving the HEATED AIR OUTLET of the heater and passing through outlet duct with louver may exceed 220°F. Make sure tent personnel are aware of burn hazards and equipment hazards presented by the heated air and the louver.

Do not attempt service procedures on a burner that has recently been in operation. Switch heater ON/OFF control to the OFF position, wait until the green HEATER ON/ON-HOLD light is OFF, and let the burner cool down before performing these procedures to avoid the possibility of serious burns.



WARNING



Gasoline, JP-4, Used Motor Oil, Solvents, Fuel Mixtures, or other unauthorized fuels should not be used with the Space Heater, Convective under any circumstance. Only JP-8 or an approved alternate fuel as detailed in WP 0002 00 and WP 0001 00 Table 2 may be used. Failure to observe fuel requirements could cause damage to the heater assembly, fire danger-potential explosion, and injury or death to personnel within or around the tent and the heater assembly.

Always place fuel can and stand in well-ventilated area as far away from open flames and other potential ignition sources as possible. Fuel spills shall be cleaned up in accordance with local requirements.

Combustible material must be kept at least 2 feet away from the sides of the heater during operation.

Always switch heater ON/OFF control to the OFF position and wait until the green HEATER ON/ON-HOLD light is OFF before refueling.



WARNING

Some metal components of SHC may have sharp edges. Wear gloves and use caution when handling and assembling the SHC to prevent cuts.

CHANGE
NO. 2

HEADQUARTERS
DEPARTMENT OF THE ARMY
WASHINGTON, D.C., 1 August 2008

TECHNICAL MANUAL

OPERATOR'S AND UNIT MAINTENANCE MANUAL
(INCLUDING REPAIR PARTS AND SPECIAL TOOLS LIST)

SPACE HEATER, CONVECTIVE
NSN: 4520-01-431-8927

DISTRIBUTION STATEMENT A. -- Approved for public release; distribution is unlimited.

TM 10-4520-262-12&P, 29 January 2002, is updated as follows:

1. File this sheet in front of the manual for reference.
2. This change is a result of several procedural changes.
3. New or updated text is indicated by a vertical bar in the outer margin of the page or at the bottom of the page, next to the footer if the majority of the content on the page changed.
4. Remove old pages and insert new pages as indicated below.

<u>Remove Pages</u>	<u>Insert Pages</u>	<u>Remove Pages</u>	<u>Insert Pages</u>
a-d	a-d	Sample 2028	Sample 2028
A/(B Blank)	A/(B Blank)	DA 2028	DA 2028
i-iii/(iv Blank)	i-iii/(iv Blank)	DA 2028	DA 2028
DA 2028 Instructions	DA 2028 Instructions	DA 2028	DA 2028

5. Replace the following work packages with their revised version:

<u>Work Package</u>	<u>Work Package</u>	<u>Work Package</u>	<u>Work Package</u>
<u>Number</u>	<u>Number</u>	<u>Number</u>	<u>Number</u>
0001 00	0010 00	0048 00	0062 00
0002 00	0018 00	0049 00	0063 00
0005 00	0023 00	0058 00	0064 00
0006 00	0042 00	0059 00	0065 00
0007 00	0044 00	0060 00	0066 00
		0061 00	0067 00

By Order of the Secretary of the Army:

GEORGE W. CASEY, JR.
General, United States Army
Chief of Staff

Official:

JOYCE E. MORROW
Administrative Assistant to the
Secretary of the Army
0820501

DISTRIBUTION:

To be distributed in accordance with initial distribution number (IDN) 256698 requirements for TM 10-4520-262-12&P.

TECHNICAL MANUAL
OPERATOR'S AND UNIT MAINTENANCE MANUAL
(INCLUDING REPAIR PARTS AND SPECIAL TOOLS LIST)
SPACE HEATER, CONVECTIVE
NSN: 4520-01-431-8927

DISTRIBUTION STATEMENT A: Approved for public release; distribution is unlimited.

TM 10-4520-262-12&P, 29 January 2002, is updated as follows:

1. File this sheet in front of the manual for reference.
2. This change is a result of several procedural changes.
3. New or updated text is indicated by a vertical bar in the outer margin of the page or at the bottom of the page next to the footer if the majority of the content on the page changed.
4. Remove old pages and insert new pages as indicated below.

<u>Remove Pages</u>	<u>Insert Pages</u>	<u>Remove Pages</u>	<u>Insert Pages</u>
a-d	a-d	Sample 2028	Sample 2028
A/(B Blank)	A/(B Blank)	DA 2028	DA 2028
i-iii/(iv Blank)	i-iii/(iv Blank)	DA 2028	DA 2028
DA 2028 Instructions	DA 2028 Instructions	DA 2028	DA 2028
			FP-1/(2 Blank)
			INDEX-1 – INDEX-8

5. Replace the following work packages with their revised version:

<u>Work Package Number</u>	<u>Work Package Number</u>	<u>Work Package Number</u>	<u>Work Package Number</u>
0001 00	0014 00	0027 00	0038 00
0002 00	0015 00	0028 00	0039 00
0004 00	0018 00	0029 00	0042 00
0005 00	0019 00	0030 00	0043 00
0006 00	0020 00	0031 00	0044 00
0007 00	0021 00	0032 00	0062 00
0008 00	0022 00	0033 00	0063 00
0009 00	0023 00	0034 00	0064 00
0010 00	0024 00	0035 00	0065 00
0012 00	0025 00	0036 00	0066 00
0013 00	0026 00	0037 00	0067 00

6. Add the following new work packages.

Work Package Number
0009 01

TM 10-4520-262-12&P
C1

By Order of the Secretary of the Army:

PETER J. SCHOOMAKER
General, United States Army
Chief of Staff

Official:

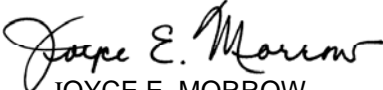
JOYCE E. MORROW
Administrative Assistant to the
Secretary of the Army
0634003

DISTRIBUTION:

To be distributed in accordance with initial distribution number (IDN) 256698 requirements for TM 10-4520-262-12&P.

LIST OF EFFECTIVE PAGES/WORK PACKAGES

NOTE: This portion of text affected by the change is indicated by a vertical bar in the outer margins of the page. Changes to illustrations are indicated by a vertical bar adjacent to the title. Zero in the "Change No." column indicates an original page or work package.

Date of issue for the original manual is:

Original 29 January 2002
 Change 1 22 December 2006
 Change 2 1 August 2008

TOTAL NUMBER OF PAGES FOR FRONT AND REAR MATTER IS 34 AND TOTAL NUMBER OF WORK PACKAGES IS 70, CONSISTING OF THE FOLLOWING:

Page / WP No.	Change No.	Page / WP No.	Change No.
Front Cover	0	WP 0034 00 (4 pgs)	1
Warning summary (4 pgs)	2	WP 0035 00 (2 pgs)	1
i-v/(vi Blank) (6 pgs)	2	WP 0036 00 (4 pgs)	1
WP 0001 00 (8 pgs)	2	WP 0037 00 (18 pgs)	1
Chp 1 title page (2 pgs)	0	WP 0038 00 (16 pgs)	1
WP 0002 00 (10 pgs)	2	WP 0039 00 (10 pgs)	1
WP 0003 00 (4 pgs)	0	WP 0040 00 (2 pgs)	0
Chp 2 title page (2 pgs)	0	WP 0041 00 (2 pgs)	0
WP 0004 00 (12 pgs)	1	WP 0042 00 (4 pgs)	2
WP 0005 00 (26 pgs)	2	Chp 6 title page (2 pgs)	0
WP 0006 00 (20 pgs)	2	WP 0043 00 (2 pgs)	0
WP 0007 00 (6 pgs)	2	WP 0044 00 (8 pgs)	2
Chp 3 title page (2 pgs)	0	WP 0045 00 (8 pgs)	0
WP 0008 00 (2 pgs)	1	WP 0046 00 (2 pgs)	0
WP 0009 00 (10 pgs)	1	WP 0047 00 (2 pgs)	0
Chp 4 title page (2 pgs)	0	WP 0048 00 (4 pgs)	2
WP 0010 00 (20 pgs)	2	WP 0049 00 (4 pgs)	2
WP 0011 00 (2 pgs)	0	WP 0050 00 (4 pgs)	0
WP 0012 00 (4 pgs)	1	WP 0051 00 (2 pgs)	0
WP 0013 00 (2 pgs)	1	WP 0052 00 (4 pgs)	0
Chp 5 title page (2 pgs)	0	WP 0053 00 (4 pgs)	0
WP 0014 00 (2 pgs)	1	WP 0054 00 (4 pgs)	0
WP 0015 00 (2 pgs)	1	WP 0055 00 (2 pgs)	0
WP 0016 00 (2 pgs)	0	WP 0056 00 (2 pgs)	0
WP 0017 00 (2 pgs)	0	WP 0057 00 (2 pgs)	0
WP 0018 00 (8 pgs)	2	WP 0058 00 (4 pgs)	2
WP 0019 00 (2 pgs)	1	WP 0059 00 (4 pgs)	2
WP 0020 00 (8 pgs)	1	WP 0060 00 (4 pgs)	2
WP 0021 00 (4 pgs)	1	WP 0061 00 (4 pgs)	2
WP 0022 00 (2 pgs)	1	WP 0062 00 (4 pgs)	2
WP 0023 00 (14 pgs)	2	WP 0063 00 (2 pgs)	2
WP 0024 00 (2 pgs)	1	WP 0064 00 (2 pgs)	2
WP 0025 00 (2 pgs)	1	WP 0065 00 (4 pgs)	2
WP 0026 00 (2 pgs)	1	WP 0066 00 (2 pgs)	2
WP 0027 00 (4 pgs)	1	WP 0067 00 (2 pgs)	2
WP 0028 00 (2 pgs)	1	WP 0068 00 (2 pgs)	0
WP 0029 00 (2 pgs)	1	WP 0069 00 (4 pgs)	0
WP 0030 00 (2 pgs)	1	WP 0070 00 (2 pgs)	0
WP 0031 00 (2 pgs)	1	Glossary	0
WP 0032 00 (2 pgs)	1	INDEX-1 - INDEX-8	0
WP 0033 00 (4 pgs)	1	F0-1	1
		Back cover	0

HEADQUARTERS,
DEPARTMENT OF THE ARMY
WASHINGTON, D.C., 29 January 2002

**OPERATOR'S AND UNIT MAINTENANCE MANUAL
(INCLUDING REPAIR PARTS AND SPECIAL TOOLS LIST)
FOR**

**SPACE HEATER, CONVECTIVE
NSN 4520-01-431-8927**

REPORTING ERRORS AND RECOMMENDING IMPROVEMENTS

You can help improve this manual. If you find any mistakes or if you know of a way to improve the procedures, please let us know. Mail your letter, DA Form 2028 (Recommended Changes to Publications and Blank Forms), directly to: TACOM Life Cycle Management Command, ATTN: AMSTA-LC-LMPP/TECH PUBS, 1 Rock Island Arsenal, Rock Island, IL 61299-7630. You may also send in your recommended changes via electronic mail or by fax. Our fax number is DSN 793-0726 and Commercial (309)782-0726. Our e-mail address is TACOMLCMC.DAForm2028@us.army.mil. A reply will be furnished to you.

DISTRIBUTION STATEMENT A – Approved for public release. Distribution is unlimited.

TABLE OF CONTENTS

	<u>WP Sequence No.</u>
WARNING SUMMARY	
HOW TO USE THIS MANUAL	
General Information.....	0001 00
CHAPTER 1 - DESCRIPTION AND THEORY OF OPERATION	
Location and Description of Major Components	0002 00
Theory of Operation	0003 00
CHAPTER 2 - OPERATOR INSTRUCTIONS	
Controls, Indicators, and Labels/Instruction Plates	0004 00
Preparation for Use	0005 00
Operation Under Usual Conditions.....	0006 00
Operation Under Unusual Conditions.....	0007 00

TABLE OF CONTENTS - Continued

WP Sequence No.

CHAPTER 3 – TROUBLESHOOTING PROCEDURES

Troubleshooting Malfunction Symptom Index	0008 00
Operator Troubleshooting Procedures	0009 00
Unit Troubleshooting Procedures	0009 01

CHAPTER 4 – OPERATOR MAINTENANCE INSTRUCTIONS

Operator Preventive Maintenance Checks and Services (PMCS)	0010 00
Operator Maintenance Procedures	0011 00
Flame Sensor	0012 00
Glow Plug	0013 00

CHAPTER 5 – UNIT MAINTENANCE INSTRUCTIONS

Unit Preventive Maintenance Checks and Services	0014 00
Unit Maintenance Procedures	0015 00
In-tent Controller Assembly	0016 00
In-tent Controller Assembly Cable	0017 00
Battery Pack Assembly	0018 00
Fuel Quick Disconnect	0019 00
Fuel Solenoid Valve and Sediment Strainer.....	0020 00
Fuel Hose	0021 00
Heater Control Assembly	0022 00
Wire Harness.....	0023 00
Power Control Assembly	0024 00
Ignition Pack Assembly	0025 00
Dust Cover Assembly.....	0026 00
Combustion Blower Assembly.....	0027 00
Combustion Blower Duct Assembly	0028 00
Combustion Air Inlet Assembly	0029 00
Upper Housing Assembly.....	0030 00
Exhaust Grommet	0031 00
Duct Adapters.....	0032 00
Heated Air Blower Assembly.....	0033 00
Fuel Pump Assembly	0034 00
Internal Fuel Lines.....	0035 00
Float Assembly.....	0036 00
Burner Assembly	0037 00
Thermoelectric Generator	0038 00
Heat Exchanger.....	0039 00
Lower Housing Assembly.....	0040 00
Return and Supply Ducts	0041 00
Preparation for Storage or Shipment.....	0042 00

CHAPTER 6 - SUPPORTING INFORMATION

References	0043 00
Maintenance Allocation Chart (MAC)	0044 00

TABLE OF CONTENTS - continued

WP Sequence No.

CHAPTER 6 - SUPPORTING INFORMATION - Continued

Repair Parts and Special Tools List (RPSTL) Introduction	0045 00
RPSTL Group 1 In-tent Controller Assembly	0046 00
RPSTL Group 2 Battery Pack Assembly	0047 00
RPSTL Group 3 External Fuel System	0048 00
RPSTL Group 4 Electronic Control System	0049 00
RPSTL Group 5 Dust Cover Assembly	0050 00
RPSTL Group 6 Combustion Blower Assembly	0051 00
RPSTL Group 7 Combustion Air Inlet Assembly	0052 00
RPSTL Group 8 Upper Housing Assembly	0053 00
RPSTL Group 9 Exhaust Grommet	0054 00
RPSTL Group 10 Duct Adapters	0055 00
RPSTL Group 11 Heated Air Blower Assembly	0056 00
RPSTL Group 12 Internal Fuel System	0057 00
RPSTL Group 13 Burner Assembly	0058 00
RPSTL Group 14 Thermoelectric Generator (TEG)	0059 00
RPSTL Group 15 Heat Exchanger	0060 00
RPSTL Group 16 Air Return and Supply Ducts With Debris Grill	0061 00
SPECIAL TOOLS LIST	0062 00
National Stock Number (NSN) Index	0063 00
Part Number Index	0064 00
Components of End Item (COEI) List & Basic Issue Items (BII) List	0065 00
Additional Authorization List	0066 00
Expendable and Durable Items List	0067 00
Lubrication Instructions	0068 00
Torque Limits	0069 00
Mandatory Replacement Parts	0070 00
Glossary	Glossary-1

ALPHABETICAL INDEX

Index-1

HOW TO USE THIS MANUAL

This manual contains General Information, Operating Instructions, Operator Preventive Maintenance Checks and Services (PCMS), Troubleshooting, and Maintenance/Repair instructions for the Convective Space Heater.

Chapter 1 contains introductory information on the SHC and its associated equipment as well as a Theory of Operation. Chapter 2 includes operating instructions under usual and unusual conditions. Chapter 3 contents include operator troubleshooting, PMCS, and service procedures. Chapter 4 contains Operator Maintenance instructions. Chapter 5 contains Unit Maintenance instructions. Chapter 6 contains references and other supporting information. Chapter 6 also includes the Repair Parts and Special Tools List (RPSTL) which identifies those parts or tools which are unique to the operation and maintenance of this equipment.

HOW TO OBTAIN TECHNICAL MANUALS

When a new system is introduced to the Army inventory, it is the responsibility of the receiving units to notify and inform the Unit Publications Clerk that a Technical Manual is available for the new system. Throughout the life cycle of the new system, the Distribution Center DOL-W will also provide updates and changes to the Technical Manual.

To receive new Technical Manuals or change packages to existing Technical Manuals (TM) for fielded equipment, provide the Unit Publications Clerk the full Technical Manual number, title, date of publication, and number of copies required. The Unit Publications Clerk will justify the request through the Unit Publications Officer. When the request is approved, the Unit Publications Clerk will use DA Form 12-R to order the series of Technical Manuals from the Army Publishing Directorate (APD).

Instructions for Unit Publications Clerk

Obtain DA Form 12-R and request a publications account from the APD Web site at <http://www.apd.army.mil>. Once on the Website, click on the "Orders/Subscriptions/Reports" tab. From the dropdown menu, select "Establish an Account," then select "Tutorial" and follow the instructions in the tutorial presentation.

Complete information for obtaining Army publications can be found in DA PAM 25-33.

Manual Organization and Page Numbering System. The manual is divided into six major chapters that detail the topics mentioned above. Within each chapter are work packages covering a wide range of topics. Each work package is numbered sequentially starting at page 1. The work package has its own page numbering scheme and is independent of the page numbering used by other work packages. Each page of a work package has a page number of the form XXXX YY-ZZ where XXXX is the work package number (e.g. 0010 is work package 10) and YY is the revision number for that work package and ZZ represents the number of the page within that work package. A page number such as 0010 00-1/2 blank means that page 1 contains information but page 2 of that work package has been intentionally left blank.

Text and Illustrations. Descriptive text and procedures are always accompanied by one or more illustrations. The text or procedure will be annotated with find numbers such as "(1)" that correspond to a specific callout on the illustration. In this technical manual, the descriptive text or procedure will always precede the illustration. Therefore, when reading a section in the manual, always look for the accompanying illustration to follow the section.

Finding Information. The Table of Contents permits the reader to find information in the manual quickly. The reader should start here first when looking for a specific topic. The Table of Contents lists the topics contained within each chapter and the Work Package Sequence Number where it can be found.

Example: If the reader were looking for instructions on “Preventive Maintenance Checks and Services”, which is an Operator Maintenance topic, the Table of Contents indicates that Operator Maintenance information can be found in Chapter 4. Scanning down the listings for Chapter 4, “Preventive Maintenance Checks and Services” information can be found in WP 0010 00 (i.e. Work Package 10).

An Alphabetical Index can be found at the back of the manual, and lists specific topics with the corresponding work package.

**SPACE HEATER, CONVECTIVE (SHC)
GENERAL INFORMATION**

SCOPE

Type of Manual. Operator's and Unit, Maintenance Manual, including RPSTL.

Part Number and Equipment Name. Part Number 5-13-5600 U.S. Army Modular Command Post System Space Heater, Convective.

Purpose of Equipment. Heats a modular command post system (Tent) or other equivalent enclosure.

MAINTENANCE FORMS, RECORDS, AND REPORTS

Department of the Army forms and procedures used for equipment maintenance will be those prescribed by DA PAM 750-8, The Army Maintenance Management System (TAMMS) Users manual; DA PAM 738-751, Functional Users Manual for The Army Maintenance Management System - Aviation (TAMMS-A); or AR 700-138, Army Logistics Readiness and Sustainability.

DESTRUCTION OF ARMY MATERIEL TO PREVENT ENEMY USE

For destruction procedures for materiel, refer to TM 750-244-3.

PREPARATION FOR STORAGE OR SHIPMENT

See unit maintenance instructions (WP 0042 00) for procedures that ensure safe storage or shipment of the heater.

NOMENCLATURE CROSS-REFERENCE LIST

Shortened nomenclature is used in this manual to make procedures easier for you to read. A cross-reference between the shortened nomenclature and the official nomenclature is shown in the following table.

Manual Nomenclature	Official Nomenclature
Flange clamp Heater	Clamp, V-Band with Nut U.S. Army Modular Command Post System Space Heater, Convective
Mat	Mat, Petroleum Absorbent
Tent	Modular Command Post System

REPORTING EQUIPMENT IMPROVEMENT RECOMMENDATIONS (EIR).

If your heater needs improvement, let us know. Send us an EIR. You, the user, are the only one who can tell us what you don't like about your equipment. Let us know why you don't like the design or performance. If you have internet access, the easiest and fastest way to report problems or suggestions is to go to <https://aeps.ria.army.mil/aepspublic.cfm> (scroll down and choose the "Submit Quality Deficiency Report). You can send your SF 368 via e-mail, regular mail, or facsimile using the address/facsimile numbers specified in DA PAM 750-8, The Army Maintenance Management System (TAMMS) Users Manual.

SAFETY, CARE, AND HANDLING**General Safety**

While in operation, the heater presents a potential burn and carbon monoxide hazard. Proper precautions should be observed while operating the heater.

Observe all warning and caution notes that appear before each maintenance operation. Refer also to the Warning Summary.

HANDLING**WARNING**

The Space Heater Convective weighs approximately 74 pounds (33.6 kg) without accessories. Two persons must carry the unit, lifting with your legs, not your back, to prevent injury. Failure to do so may result in serious back or other musculo-skeletal injuries.

**WARNING**

Do not remove the heater assembly while any of the advisory lights are lit.

Small, portable, shelter heaters of this type are not designed to be moved during operation or before purge cycles are complete. Serious injury, burns, or death can occur if the heater assembly is moved while operating or before the HEATER ON/ON-HOLD advisory light goes OFF indicating the end of operation, post purge, and cool down cycle completion.

During operation some metal components of the heater assembly become extremely hot, such as the grill on the outlet duct, the upper and lower heater housing assemblies, combustion exhaust pipe, etc., Contact with bare skin can cause severe burn injuries.

During heater operation, air leaving the HEATED AIR OUTLET of the heater and passing through outlet duct with grill may exceed 220°F. Make sure tent personnel are aware of burn hazards and equipment hazards presented by the heated air and the grill.

Combustible material must be kept at least 2 ft away from, the sides of the heater during operation.

Do not attempt service procedures on a burner that has recently been in operation. Switch heater ON/OFF control to the OFF position, wait until the green HEATER ON/ON-HOLD light is OFF, and let the burner cool down before performing these procedures to avoid the possibility of serious burns.

CORROSION PREVENTION AND CONTROL (CPC)

Corrosion Prevention and Control of Army materiel is a continuing concern. It is important that any corrosion problems with this item be reported so that the problem can be corrected and improvements can be made to prevent the problem in future items.

While corrosion is typically associated with rusting of metals, it can also include deterioration of other materials, such as rubber and plastic. Unusual cracking, softening, swelling, or breaking of the materials may be a corrosion problem.

If a corrosion problem is identified, it can be reported using Standard Form 368, Product Quality Deficiency Report. Use of key words such as "rust," "deterioration," "corrosion," or "cracking" will ensure that the information is identified as a CPC problem. The form should be submitted to the address specified in DA PAM 750-8.

LIST OF ABBREVIATIONS/ACRONYMS

AAL	Additional Authorization List	MCPS	Modular Command Post System
AMP	Ampere	m	Meter
Approx	Approximately	mm	Millimeter
BD	Bundle	MSDS	Material Safety Data Sheet
BE	Bale	MTOE	Modified Table of Org and Equipment
BII	Basic Issue Item	MWO	Modification Work Order
BTU	British Thermal Unit	NBC	Nuclear, Biological, Chemical
BX	Box	NHA	Next Higher Assembly
°C	Degrees Celsius	NSN	National Stock Number
CAGEC	Commercial And Government Entity Code	N-m	Newton Meters
CFM	Cubic Feet per Minute	OZ	Ounce
Cm	Centimeter	PAM	Pamphlet
COEI	Component of End Item	PMCS	Preventive Maintenance Checks and Services
CPC	Corrosion Prevention Control	POL	Petroleum, Oil and Lubricant
CTA	Common Table of Allowances	psi	Pounds Per Square Inch
DA	Department of the Army	QD	Quick Disconnect
DOZ	Dozen	Qty	Quantity
DC	Direct Current	Ref	Reference
ea/EA	Each	Rqd	Required
EIR	Equipment Improvement Recommendation	RL	Roll
FGC	Functional Group Code	RPSTL	Repair Parts and Special Tools List
FT	Foot	RTV	Room Temperature Vulcanizing
gal	Gallons	SHC	Space Heater, Convective
GFA	Gravity Feed Adapter	SMR	Source Maintenance and Recoverability
GFE	Government Furnished Equipment	SRA	Specialized Repair Activity
GL	Gallon	SOP	Standard Operating Procedure
HR/hr	Hour	TDA	Table of Distribution and Allowances
IAW	In Accordance With	TEG	Thermoelectric Generator
ID	Inside Diameter	™	Trademark
Illus	Illustrated / Illustration	TMDE	Test, Measurement, Diagnostic Equipment
in.	Inches	TOE	Table of Organization and Equipment
in.-lb	Inch-pound	TU	Tube
JTA	Joint Table of Allowances	TWMK	Tent Wall Modification Kit
k/PA	Kilopascals	U/I	Unit of Issue
Kg	Kilogram	UOC	Usable On Code
L	liter	V	Volt
lbs	Pounds	VDC	Volt Direct Current
lb-ft	Pound-foot	WP	Work Package
MAC	Maintenance Allocation Chart		
MAX	Maximum		

EQUIPMENT CHARACTERISTICS, CAPABILITIES, AND FEATURES

The Modular Command Post System (MCPS), hereafter referred to as the tent, requires a heat source. This heater fulfills the need for an independent, powerful, self-powered, self-sustaining, self-regulating, self-diagnostic heater.

The heater is set up for operation outside the tent. The tent control assembly (with controls, visual advisory lights, and an audible alarm) must be mounted inside the tent and a control cable (remote) used to connect the tent control assembly to the heater.

The operation of the heater is controlled by the ON-OFF switch, the LOWER-HIGHER control knob (both located on the control assembly), and the heater control assembly (located within the heater itself).

Manual movement of the ON/OFF switch to the ON position will cause the heater to automatically execute a series of steps that lead to heater operation. Manual movement of the ON/OFF switch to the OFF position will cause the heater to automatically execute a safe and orderly shutdown.

The status of the heater assembly can be determined by looking at the advisory lights on the tent control assembly or by listening to the audible alarm. These lights and the related audible alarm are controlled by the heater control assembly, which monitors the normal operation of heater, and, when an abnormal operating condition is detected, cause the heater to shut off. Also, when an abnormal operating condition is detected, the SYSTEM FAULT advisory light and the integral audible alarm are activated and pulse out the following SYSTEM FAULT diagnostic codes:

Table 1. System Fault Diagnostic Codes.

Number of Pulses and Audible Tones	System Fault
1	LOW VOLTAGE
2	COMBUSTION BLOWER
3	LOSS OF FLAME
4	BURNER MAINTENANCE
5	GLOW PLUG
6	TEG OVER TEMPERATURE
7	OVER VOLTAGE
8	TIP-OVER
9	FIN TEMP SENSOR
10	TENT OVER TEMPERATURE
11	NOT USED
12	BATTERY BELOW 10 VOLTS

JP-8 is the preferred fuel for all temperature conditions because it burns cleaner than other approved fuels and will provide the best heater performance, reducing the frequency of required burner maintenance. Use of diesel fuel will require regular burner cleaning every 250 operating hours. Alternate fuels are listed in Table 2 below.

Table 2. Approved Fuels at Various Temperatures.

Primary Fuel	Ambient Temperature	Specification
JP-8	Above -60°F (-51.1°C)	MIL-DTL-83133E
Alternate Fuels	Ambient Temperature	Specification
K-1 (Kerosene)	Above -25°F (-31.7°C)	
DF-A	Above -60°F (-51.1°C)	A-A-52557A
DF-1	Above -25°F (-31.7°C)	A-A-52557A
JP-5	Above -25°F (-31.7°C)	MIL-DTL-5624U
DF-2	Above +20°F (-6.7°C)	A-A-52557A

TM 10-4520-262-12&P

CHAPTER 1

**DESCRIPTION AND
THEORY OF OPERATION**

SPACE HEATER, CONVECTIVE

SPACE HEATER, CONVECTIVE (SHC)
LOCATION AND DESCRIPTION OF MAJOR COMPONENTS

The following are the major components of the Space Heater, Convective. A brief description of the function of each component and its location is detailed below.

In-Tent Controller Assembly (1)

The in-tent control assembly (1) contains the operator controls and advisory lights for the heater. The in-tent control assembly is a remotely wired, splash proof box that can be easily attached to the tent framework. The in-tent controller assembly is only intended for use inside the tent.

In-Tent Controller Cable Assembly (2)

An in-tent controller cable assembly (2) is used to connect the in-tent controller assembly to the heater.

Battery Pack Assembly (3)

The battery pack assembly consists of a 12-volt lead-acid gel cell battery (3) with an electrical heating element. The battery pack assembly location is clearly marked and is located in a recess (4) below the lower housing assembly. Two fuse holders (5) carrying 20 amp fuses are incorporated into the side of the battery pack. Two spare fuses (6) are located at the breathable air inlet end of the heater.

The battery is used for burner ignition, and to power the control system until the thermoelectric generator (TEG) generates power. The battery is recharged during heater operation by the TEG. Depending on battery condition and temperature, the battery has a approximate 30-minute recharge time.

If battery temperatures are below 40°F (4.4°C), it is electrically heated by the heating element. When the battery reaches 60°F (15.6°C), the heating element is shut off by the controller. When battery heat is called for, only excess power is used for heating the tent.

Combustion Air Inlet Assembly (7)

The combustion air inlet assembly (7) is connected to the combustion air blower located inside the heater and is the source of outside air used for combustion by the burner assembly.

Upper Housing Assembly (8)

The upper housing assembly (8) consists of a compartment cover assembly having certain hardware and electrical wiring and connections mounted on it.

Lower Housing Assembly (9)

The frame and heater housing are welded together to form the lower housing assembly (9).

Fuel Solenoid Valve Assembly (10)

The fuel solenoid valve assembly (10) has a normally closed valve, which opens to allow fuel to enter the heater when the ON/OFF switch is in the ON position. The solenoid valve is closed when the switch is turned OFF or if heater control assembly detects a SYSTEM FAULT condition. This solenoid is independent of the fuel pump assembly described below.

Fuel Quick Disconnect (11)

A fuel quick disconnect (11) is located at the inlet side of the fuel solenoid valve assembly (10). This military style male fitting has a protective dust cap (12) chained to it for use when the heater is not connected to the fuel supply.

Operating Instructions Plate

Operating instructions plate (13) is provided on the in-tent control assembly (1).

LOCATION AND DESCRIPTION OF MAJOR COMPONENTS – Continued

Air Supply Duct with Debris Grill (14)

The air supply duct with debris grill (14) conducts air from the tent to heater assembly for warming. This duct is 10.5 inches in diameter and has a debris grill (15) to prevent accidental entry of foreign objects into the heater assembly. A strap is used to connect the duct to the heater inlet. Note that upon initial shipment, the debris grill is not installed in the duct. The debris grill must be installed in the duct prior to using the heater IAW WP 0005 00.

An airflow direction arrow tag (16) is permanently attached to the duct indicating that the flow of air moves from the debris grill end of the duct to the open end that connects to the heater.

Air Return Duct with Debris Grill (17)



WARNING

Do not touch the metal debris grill of the air return duct while the heater is running. During heater operation the metal debris grill and the heated air coming from it can be as hot as 220°F (104°C). Touching the metal debris grill may result in serious burns.

The air return duct with debris grill (17) conducts heated (breathable) air from the heater assembly to tent. This duct is 10.5 inches in diameter and has a debris grill (17) to prevent accidental entry of foreign objects into the heater assembly. A strap is used to connect the duct to the heater outlet duct adapter. Note that upon initial shipment, the debris grill is not installed in the duct. The debris grill must be installed in the duct prior to using the heater IAW WP 0005 00.

An airflow direction arrow tag is permanently attached to the duct indicating that the flow of air moves from the open end that connects to the heater to the debris grill end of the duct that is installed in the tent duct tunnel.

Accessory Bag (18)

An accessory bag is provided to permit stowage of all loose Space Heater Convective items such as the air inlet and return ducts, in-tent controller assembly and cable, battery charger, gravity feed adapter, fuel hose, and fuel can stand.

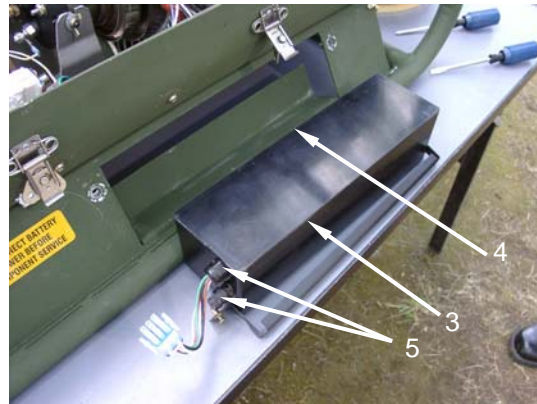
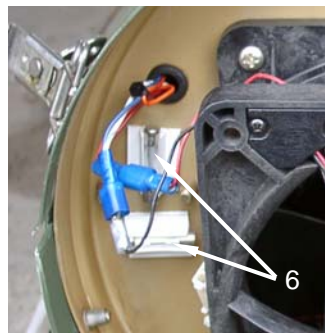

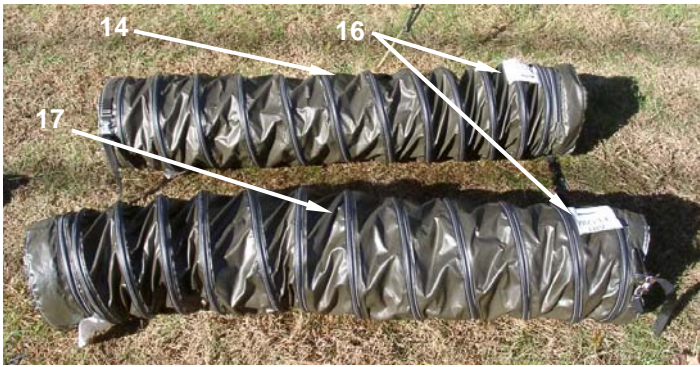
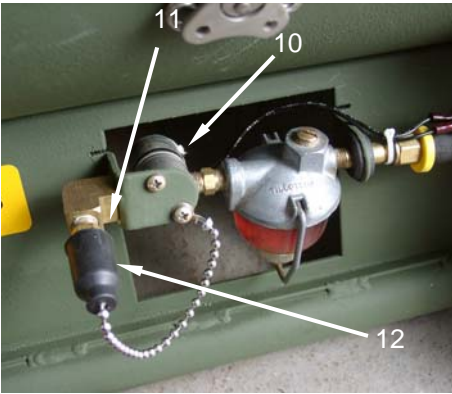
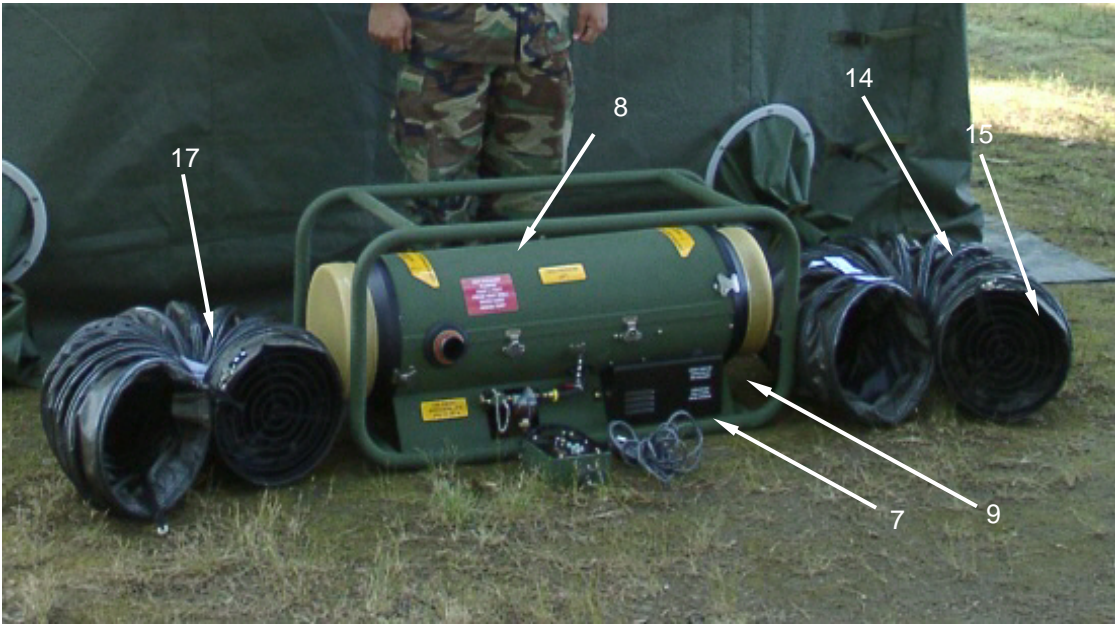

Burner Assembly (1)

The burner assembly (1) consists of a vaporization type burner. The burner assembly uses a glow plug (2) for starting and requires no power other than the combustion blower (3) and the fuel pump (4) to operate. During starting, an ignition pack (5) provides approximately 24 volts to the glow plug to improve cold weather performance. An external fuel drain (6) is also provided on the burner assembly to facilitate draining the fuel system.

Heater Control Assembly (7)

The heater control assembly (7) uses information from the heater's sensors and the tent control assembly to determine the ideal firing rate. The air/fuel ratio is adjusted as needed to maintain the ideal firing rate.

The heater control assembly (7) is located on the inside lower housing opposite the battery compartment and is clearly marked. The heater control assembly controls all electrical functions, including system startup, shutdown, and safety checks. It includes temperature and tilt sensors and the control circuit. The control circuit analyzes information from the sensors to maintain the optimum firing rate for the heater. To maintain the firing rate, it controls the rates of fuel flow and air flow, and continuously monitors the in-tent control assembly settings to verify that the desired settings are reached.

The control system also controls system startup and shutdown, and monitors the heater safety systems. If a fault is detected, it immediately begins the shutdown procedure and signals the operator that a fault has occurred.

Combustion Air Blower (3)

The combustion air blower assembly (3) integrates a 12-volt direct current (DC) combustion air fan (8). It is located in the lower heater housing directly below the control cable electrical connector and is clearly marked. The combustion air blower (3) draws air through the combustion air inlet (9) and passes it through flexible hoses (10) to the burner assembly (1).

Heated Air Blower Assembly (11)

A heated air blower assembly (11) is mounted under the duct adapter (12). It features a 12-volt DC fan in series at the inlet end of the heater. The fan moves approximately 250 cubic feet per minute (CFM) of heated, breathable air when operating.

The heated air blower assembly (11) forces fresh air or air removed from the tent through the heater. This air passes across the TEG and the heat exchanger, where it absorbs heat and is directed into the tent.

Since the heater is designed to provide a variable British Thermal Units per hour (BTU/HR) output and still maintain internal generation of system and battery electricity, the heater needs to regulate between being a heater and being a generator of electricity as operational requirements change. This electronic marriage of components allows for a safe and smooth transition from generation of electricity to heating. The selection of a sophisticated controller reduces the amount of training required to operate the heater and provides continuous monitoring and control of the heater.

Fuel Pump (4)

The fuel pump (4) is controlled by frequency pulses from the heater control assembly and is responsible for supplying fuel in a vaporized state to the burner assembly.

Heat Exchanger (13)

The heat exchanger (13) transfers heat from hot gases produced by the burner to the heated (breathable) air. The heat exchanger is sandwiched between the upper housing assembly and the lower housing assembly. The heat exchanger provides an outlet and mounting flange for the combustion exhaust pipe (14) and an O-ring seal and gasket (15). This heated (breathable) air is then used to heat the tent. The heated air runs over the outside of the heat exchanger to collect the heat. The hot gases, or combustion fumes, inside the heat exchanger are exhausted outside the enclosure through the combustion exhaust pipe (14).

Thermoelectric Generator (16)

The thermoelectric generator (TEG) (16) provides heater system operating and battery recharging electrical power. Once the TEG is operating at full power, it supplies enough energy to operate the heater assembly and maintain a battery charging voltage of 14.5 volts. When the battery pack has been fully charged, the extra energy the TEG creates is converted into heat and used to heat the shelter.

The TEG includes a mantle which directs the hot gases exiting the burner assembly to evenly heat the inside diameter (ID) of the TEG. This improves the ability of the TEG to generate electrical power.

Power Control Assembly (17)

The power control assembly is housed on a printed circuit board and mounted to the side wall of the lower housing assembly. The power control board manages the distribution of power throughout the Space Heater Convective.

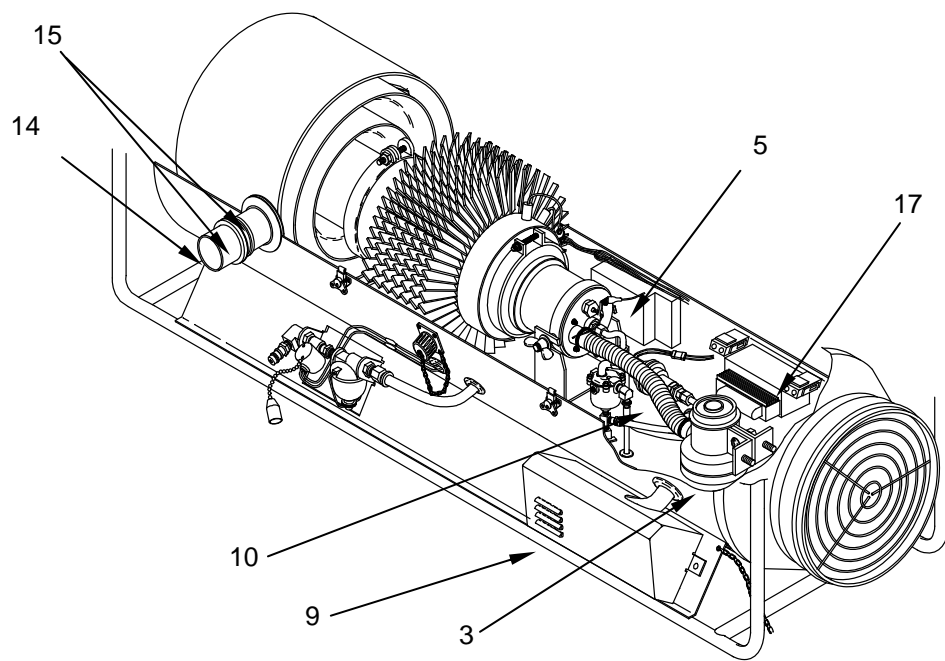
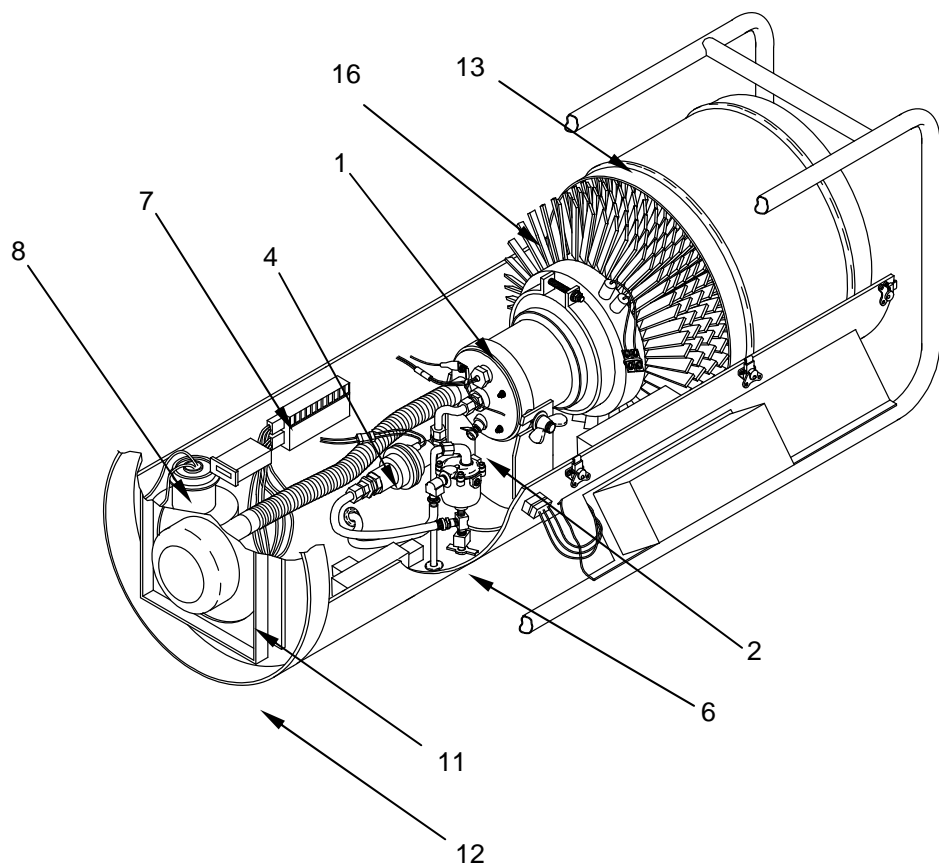

ONBOARD SPARES AND TOOLS. In addition to the foregoing major components, each space heater, convective package includes onboard spares and/or tools listed in Table 1. All the spares and tools are stored behind the duct adapter at the end of the heater labeled "Breathable Air Inlet" with the exception of the battery charging adapter. The battery charging adapter is stored in the Accessory Bag.

Table 1. Onboard Spares and Tools.

Item	Name	Qty	Item	Name	Qty
1	Glow plug	1	5	Wrench	1
2	Flame sensor	1	6	Sediment Strainer Gasket	1
3*	Battery charging adapter	1	7	Sediment Strainer Screen	1
4	Battery pack fuses 20 amp	2			

* Battery charging adapter stored in accessory bag.

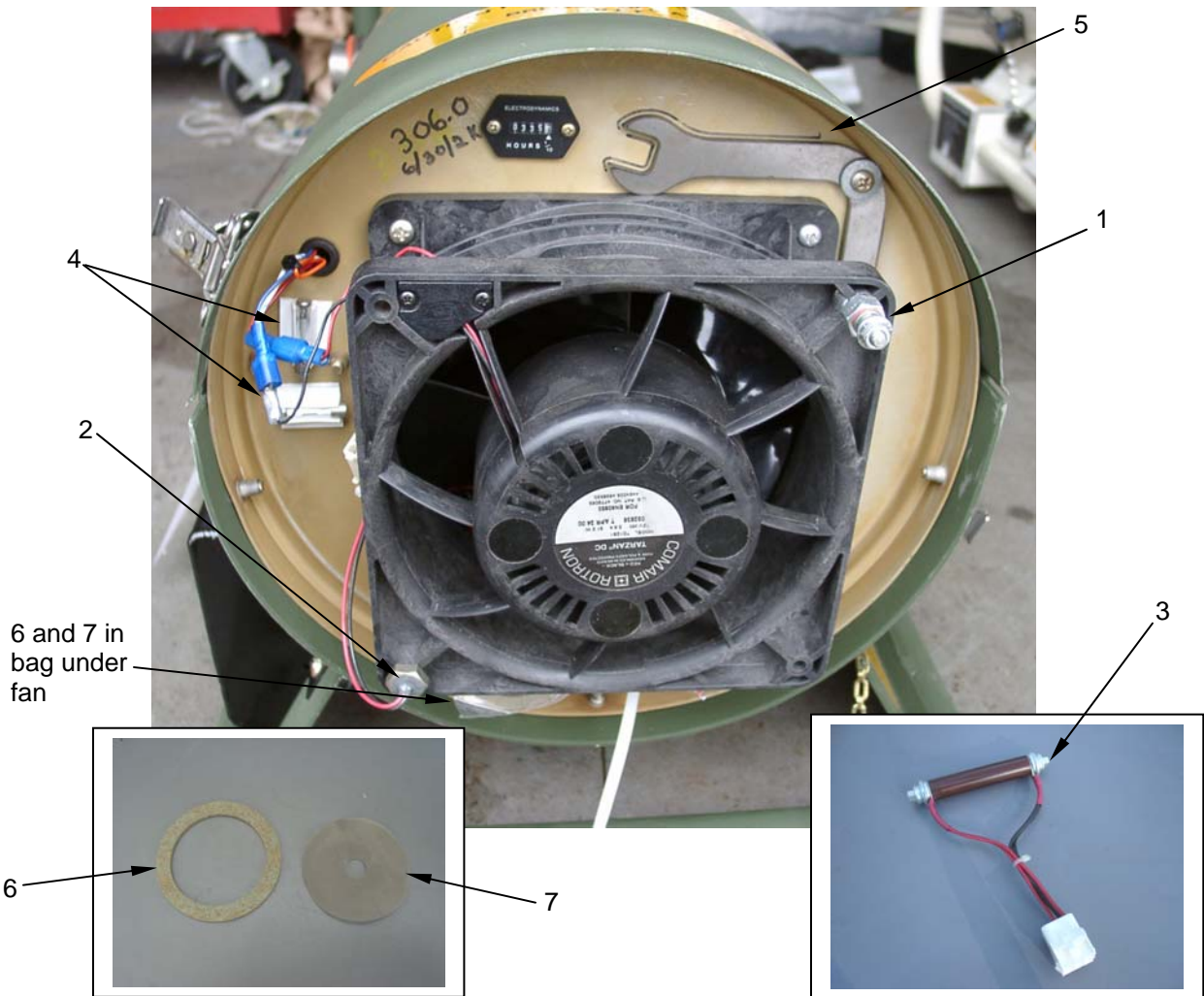

ADDITIONAL EQUIPMENT REQUIRED FOR USE WITH THIS HEATER

FUEL CAN. The 5 gallon (18.9 L) fuel can, listed on the AAL, provides a fuel source during heater operation.

Table 2. Equipment Data.

Manufacturer	Hunter Manufacturing Company
Part number	5-13-5600
Operating temperature range	+65°F(+18.3°C) -60°F (-51.1 °C)
BTU/Hr (automatically variable)	
Low	28,000
High	35,000
Efficiency	75-82%
Electrical system	10.50-14.75 volts DC
Glow plug	11.5 volts DC (Starting only)
Fuses, Spare Battery Pack – 20 amp	2 each
Battery Pack Fuses – 20 Amp	2 each
Combustion air fan	12 volt DC Rotron Revaflow™
Air flow	
Heated air (breathable) high fire rate	250 CFM
Heated air temperature rise	140°F (60°C)
Maximum at duct debris grill	240°F (115°C)
Combustion air outlet temperature (exhaust)	400-600°F (204-316°C)
Heater dimensions (without accessories)	
Length	40.50 inches (102,87 cm)
Width	14.25 inches (36,19 cm)
Height	18.37 inches (46,66 cm)
Heater volume	6.202 cubic feet (0,1756 m ³)
Heater weight (without accessories)	74 pounds
Fuel requirements:	
Primary Fuel:	
Above -60°F (-51.1°C)	MIL-DTL-83133E (JP-8)
Alternate Fuels	
Above -25°F (-31.7°C)	Kerosene (K-1)
Above -60°F (-51.1°C)	A-A-52557A (DF-A)
Above -25°F (-31.7°C)	A-A-52557A (DF-1)
Above -25°F (31.7°C)	MIL-DTL-5624U (JP-5)
Above +20°F (-6.7°C)	A-A-52557A (DF-2)
Fuel consumption	2 hours/gal. (maximum) 3.5 hours/gal. (average)

Table 2. Equipment Data - Continued

Minimum safe distance to combustibles	2 feet
Battery pack (with heater)	
Type	Starved electrolyte (gel cell)
Rating	
Burner assembly	
Glow plug	11.5-12 volts
All other electrical components	12-24 volts
Manufacturer	Gates
Battery Pack	1 each
Thermoelectric generator (TEG)	
Manufacturer	Global
Type	Lead telluride (vacuum sealed)
Rating	180 watts, 15 amps

**SPACE HEATER, CONVECTIVE (SHC)
THEORY OF OPERATION**

The Space Heater, Convective (1) is installed outside the tent with its air supply (2) and return (3) ducts routed through passthrough sleeves (4) located in the side of the tent (5). A fuel can (6) mounted on a fuel can stand (7) feeds fuel to the space heater by means of a gravity feed adapter (8) and fuel hose (9). The fuel hose (9) is connected to the SHC by means of a quick disconnect connector (10).

All SHC functions are controlled via the in-tent controller assembly (11) which hangs inside the tent. An in-tent controller assembly cable (12) is connected between the in-tent controller assembly and the heater in order to control all heater operations from inside the tent.

An SHC operational cycle begins by switching the ON-OFF switch (13) on the in-tent controller assembly (11) to the ON position.

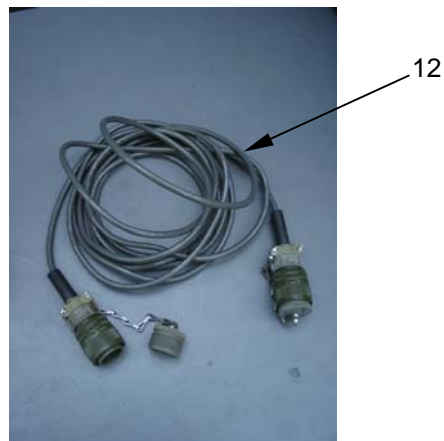
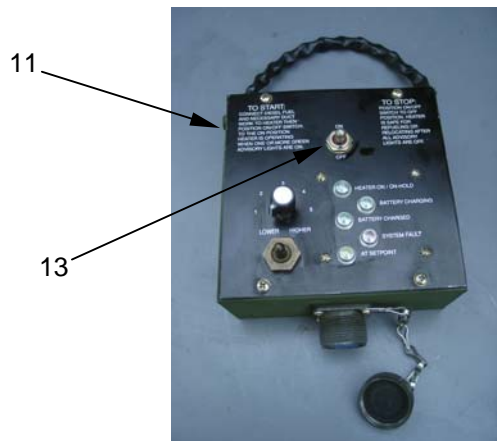
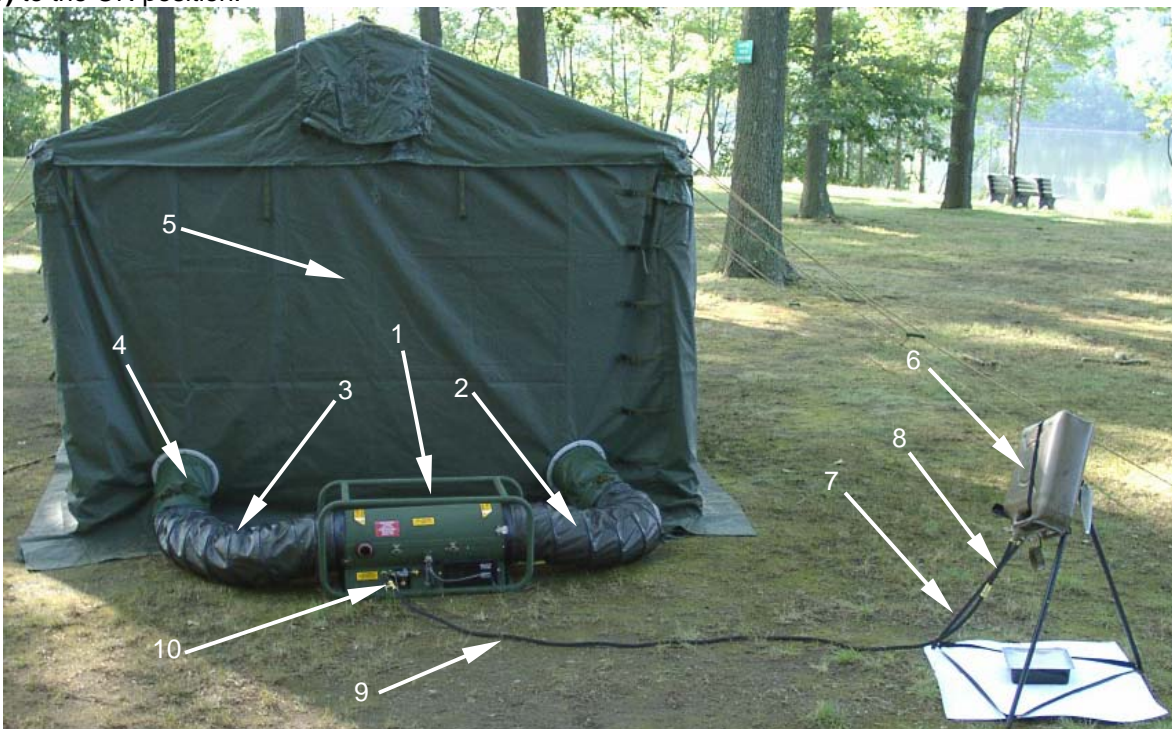

Placing the ON/OFF switch of the in-tent controller in the ON position sends a signal to the power control assembly **(1)** as well as to the heater control assembly **(2)** energizing the system. At this point the "heater on/on-hold" advisory light **(3)** on the in-tent controller will illuminate, indicating the heater has begun operation. After a wait of five seconds a visual audible function check of the in-tent controller is made. The battery charging light, battery charged light and system fault light are illuminated with the audible tone for approximately two seconds.

A battery pack **(4)** is used to supply power to the heater assembly **(1)** and facilitate burner ignition until the thermoelectric generator (TEG) **(5)** begins generating power. The power drawn from the batteries is replaced by the TEG while the heater delivers heat to the shelter.

Once power is applied to the system, the heater control assembly **(2)** sends a signal to the fuel solenoid valve assembly **(6)**, opening the valve and allowing fuel to flow through the sediment strainer **(7)** to the float assembly **(8)**. Power is supplied to preheat the glow plug **(12)**. Fuel is then pumped in short pulsating bursts by the fuel pump **(9)** to the burner head assembly **(10)**, where it is vaporized from the heat of the glow plug.

Air that is drawn through the combustion air inlet is mixed with the hot vaporized fuel providing oxygen for flame ignition. Heat produced from this combustion is converted to electrical power by the thermoelectric generator (TEG) **(5)**. The TEG provides electricity which is used to recharge the batteries. When the batteries are charging, the "battery charging" advisory light **(14)** on the in-tent controller assembly illuminates. The heater continues to run as the batteries recharge.

When the batteries **(4)** are fully recharged, the "battery charged" advisory light **(15)** on the in-tent controller assembly illuminates and the "battery charging" light **(14)** is extinguished. At a specified temperature measured at the TEG, the heated air blower assembly **(16)** is engaged and cold air is drawn from the shelter through the air supply duct **(17)** and forced through the heat exchanger **(18)** at the outlet end of the heater. The shelter air is heated and forced out the air return duct **(19)** into the shelter as heated air.

As heated air is supplied to the shelter, the temperature inside the shelter rises. This temperature is monitored by a sensor **(20)** on the in-tent controller assembly. When the shelter temperature reaches the value set on the "lower/higher" control **(21)** on the in-tent controller assembly, a signal is sent to the heater. The fuel pump and combustion air are slowed down reducing the heat supplied to the shelter. Air continues to circulate through the shelter via the heated air blower assembly **(16)** and the "At Setpoint" advisory light **(22)** illuminates.

If the shelter temperature exceeds approximately 90 degrees F, the in-tent controller will shut off the heater. The heater on/ on hold light will remain on. When the shelter cools the heater will begin a normal start cycle.

Heater operation is terminated by switching the ON/OFF switch **(23)** on the in-tent controller to the OFF position. The fuel solenoid valve **(6)** is closed and all fuel flow to the burner assembly **(10)** ceases. When all advisory lights are extinguished, the heater is shut down and can be moved or left in place for another operational cycle.

If a system fault occurs during operation, the heater control assembly (2) monitors this condition and sends a signal to the in-tent controller illuminating the "System Fault" advisory light (24) on the in-tent controller.

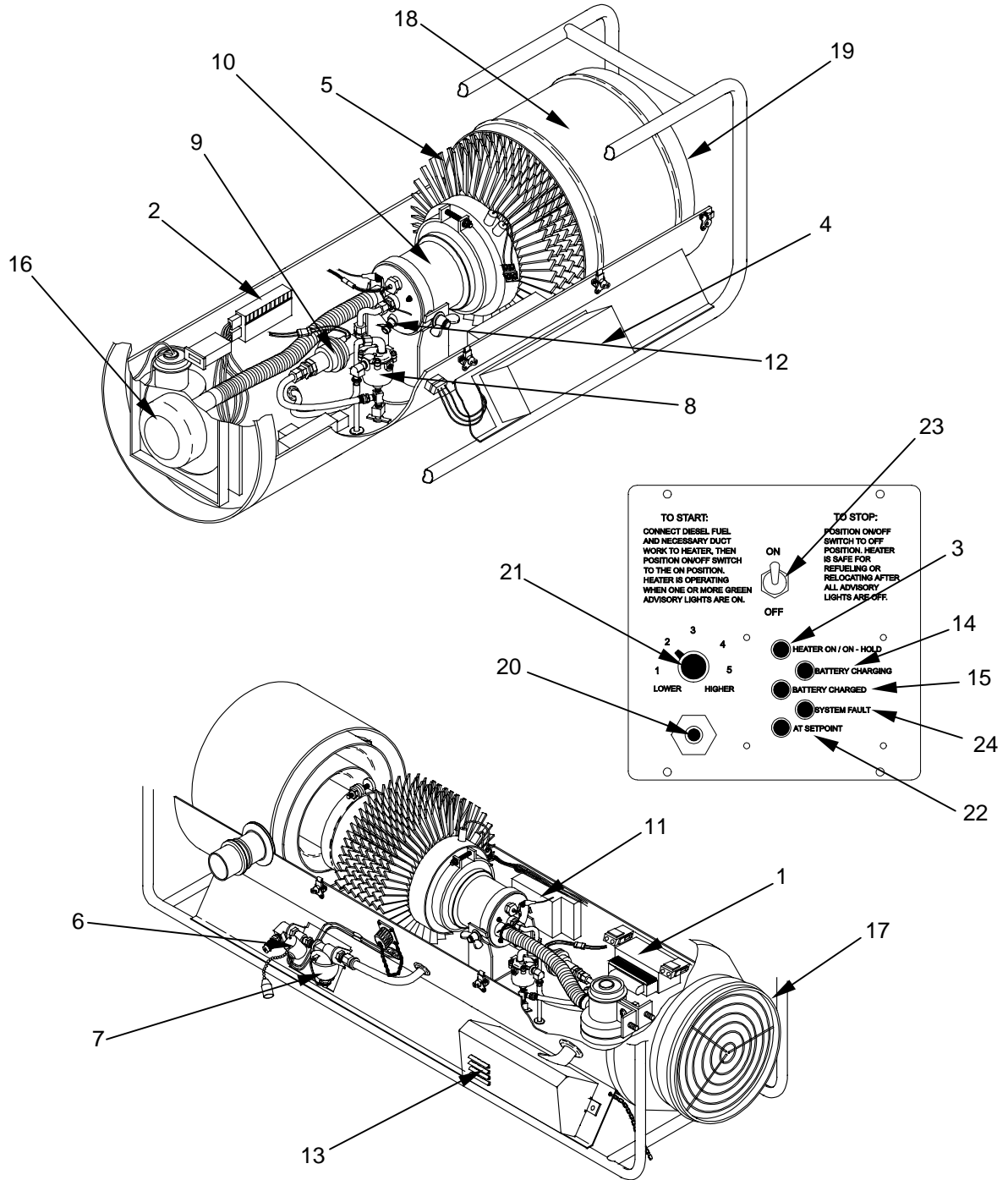

TM 10-4520-262-12&P

CHAPTER 2
OPERATOR INSTRUCTIONS
SPACE HEATER, CONVECTIVE

SPACE HEATER, CONVECTIVE (SHC) CONTROLS, INDICATORS, AND LABELS/INSTRUCTION PLATES

GENERAL

This section contains information on the controls, indicators, and label/instruction plates located on the Convective Space Heater.

Before operating the heater, the user should become familiar with the controls and indicators provided on the unit. The operating controls are installed on the in-tent control assembly **(1)** and on the lower housing assembly **(2)**.



HEATER CONTROLS AND INDICATORS

The description and function of the controls and indicators of the in-tent controller assembly are detailed in Table 1. The manual reset thermostat located on the lower housing assembly is described in Table 2.

Table 1. In-Tent Control Assembly Controls and Indicators.

Key	Name	Function
1	ON-OFF switch	Controls starting and stopping of the heater. Movement of the ON/OFF switch from one position to another initiates the step-by-step transition of the heater from one operating condition to another (the OFF condition to the ON condition, or the ON condition to the OFF condition). This step-by-step transition is controlled and timed by the heater control assembly, and not by the movement of the ON/OFF switch.
2	HEATER ON/ON-HOLD light (green)	When lit, indicates the heater assembly is in one of the following modes: 1) pre-purge, 2) normal operation, 3) on-hold. The on-hold mode means that the heater is not operating but it is ready to start in response to changes in the tent temperature or changes to the LOWER-HIGHER control settings.
3	LOWER/HIGHER control knob	Controls the setpoint that the heater is trying to reach, thereby controlling the heat output of the heater. Adjusting the control knob causes the heater assembly to provide higher or lower heat outputs to the tent. When the temperature within the tent reaches the setpoint, an amber AT SETPOINT light glows. When the temperature sensor registers this temperature, the heater begins to regulate its output so that the temperature is maintained.
4	BATTERY CHARGING light (green)	When lit, indicates the heater assembly battery is being charged by the TEG. While this light is lit, the heater's electronic controller does not allow the heater to respond to the LOWER-HIGHER control knob settings unless all the electrical requirements of heater operation and battery charging are met.
5	BATTERY CHARGED light (green)	When lit, indicates the heater assembly battery is fully charged and the heater will respond fully to the changes in tent temperature or changes to the LOWER-HIGHER control knob settings. Once this light comes on, the heater can be turned off with assurance that the battery is fully charged and there will be enough power for the next startup.
6	SYSTEM FAULT light (red)	When this advisory light is pulsing and the related audible alarm (also located within the tent control assembly) is buzzing, it indicates the heater assembly sensors and the electronic heater control assembly have detected an unsafe operating condition and the heater has begun to shut itself off. This advisory light and audible alarm provide a sequence of from 1 to 12 pulses that correspond to diagnostic codes explaining the cause of SYSTEM FAULT. See back of the heater control assembly for diagnostic codes.
7	AT SETPOINT light (amber)	When lit, indicates the interior tent temperature is at or above the LOWER-HIGHER control setting.

Table 1. In-Tent Control Assembly Controls and Indicators - Continued.

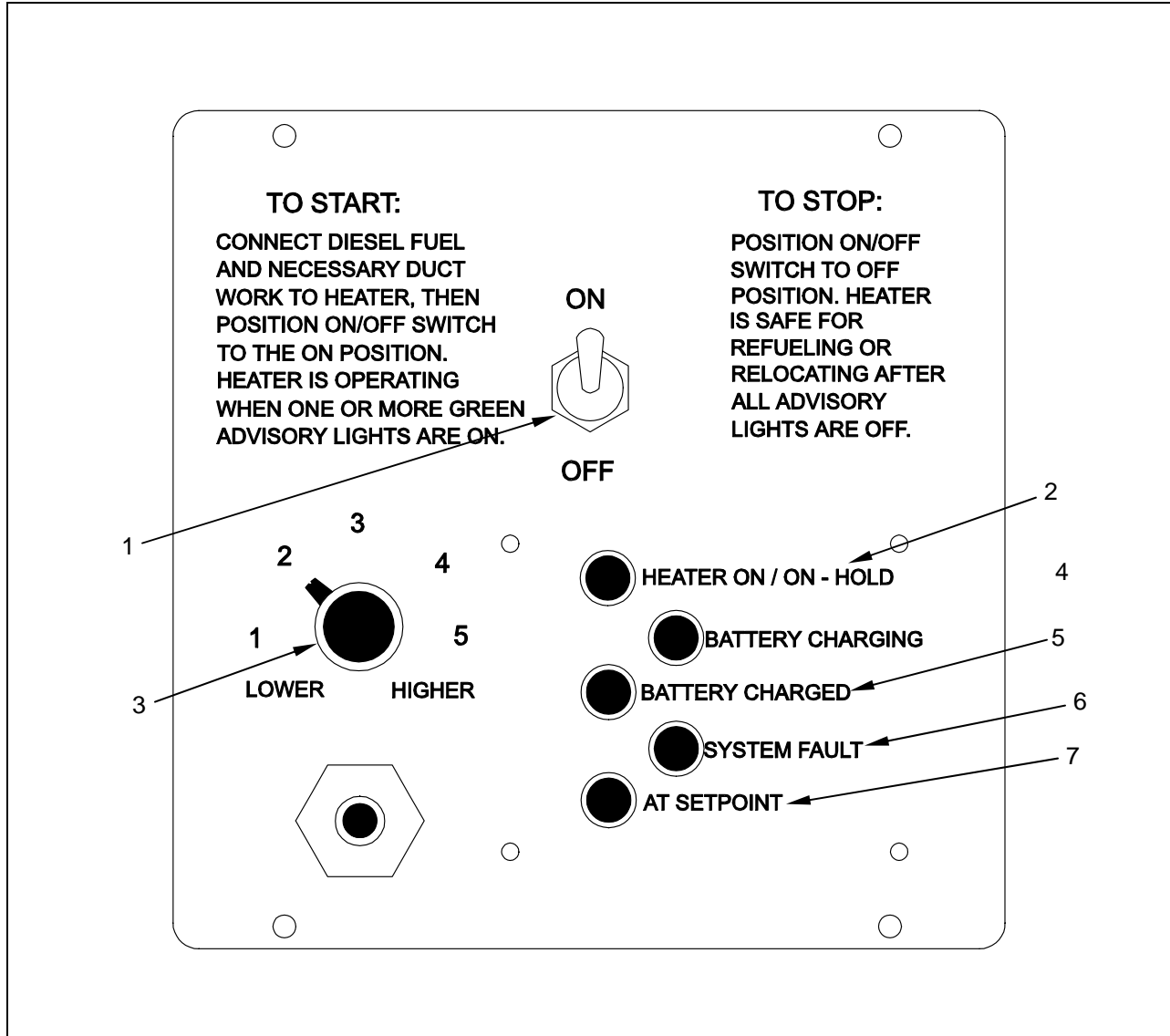

Table 2. Lower Housing Assembly Controls and Indicators.

Key	Name	Function
8	Manual Reset Thermostat	<p>A manual reset thermostat (1) comprising a high-temperature cutout with a built-in reset switch is located on the lower portion of the heater housing. Its purpose is to backup the temperature sensors of the heater control system. In a situation where the heat exchanger overheated and the heater controller did not shut down the heater, this manual reset thermostat would activate and cut off all electrical power to the heater, thus causing the heater to shut down; Once the heater is determined to be safe for operation, the manual reset thermostat must be reset by pushing the reset switch button located underneath the rubber protector that is located on the heat exchanger end of the heater.</p>



LABELS AND INSTRUCTION PLATES

Table 3 illustrates the decals and information plates.

Table 3. SHC Labels and Instruction Plates.



Label or Instruction Plate	Location Code
 <p>DISCONNECT BATTERY POWER BEFORE COMPONENT SERVICE</p>	1
 <p>US HEATER, SPACE, CONVECTIVE 35,000 BTU/HR NSN PART NO. MFD BY CONTRACT NO. DATE SERIAL NO. WT LB</p>	2
 <p>WARNING REMOVE BATTERIES BEFORE SHIPMENT OR INACTIVE STORAGE OF 30 DAYS OR MORE. MIL-STD-454N REQUIREMENT 27</p>	3
<p>* Label from the earlier model</p>  <p>USE JP-8, DFA, DF-1, DIESEL, K-1,</p>	4

Table 3. SHC Labels and Instruction Plates - Continued.

<p>* Label from the current model</p> <div style="border: 1px solid black; padding: 5px; width: fit-content; margin: 10px auto;"> <p>PRIMARY FUEL: JP-8 ALTERNATE FUELS: K-1, DFA, DF-1, JP-5, DF-2</p> </div>	<p>4</p>
<div style="border: 1px solid black; padding: 10px; text-align: center;"> <p>CAUTION OUTLET SURFACE IS HOT</p> <p>↓ HEATED AIR ↓ OUTLET</p> </div>	<p>5</p>
<div style="border: 1px solid black; padding: 20px; text-align: center; width: fit-content; margin: 10px auto;"> <p>HOT EXHAUST FLANGE KEEP 2 FEET FROM TENT WALL</p> </div>	<p>6</p>
<div style="border: 1px solid black; padding: 10px; text-align: center; width: fit-content; margin: 10px auto;"> <p>TWO PERSON LIFT</p> </div>	<p>7</p>
<div style="border: 1px solid black; padding: 10px; text-align: center;"> <p>CAUTION KEEP INLET AREA CLEAR</p> <p>↑ BREATHABLE AIR ↑ INLET</p> </div>	<p>8</p>

Table 3. SHC Labels and Instruction Plates - Continued.

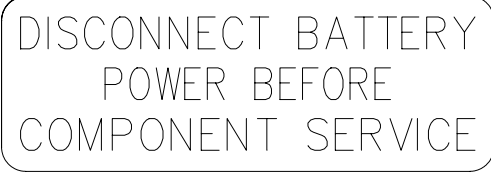
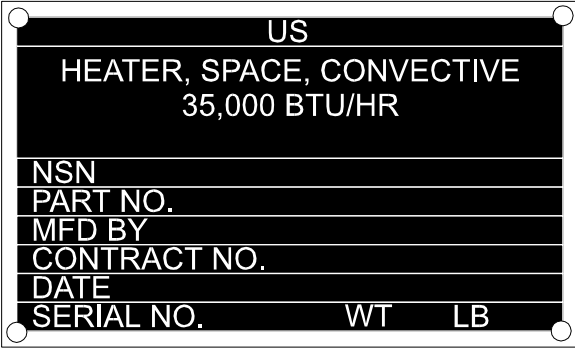
<div style="border: 1px solid black; border-radius: 15px; padding: 10px; text-align: center;"> <p>CLEAN AIR INLET AREA OF DEBRIS BEFORE OPERATION</p> </div>	<p>9</p>
<p>* Previous Model Configuration Label</p> <div style="border: 1px solid black; padding: 10px; margin: 10px auto; width: 80%;"> <p>AUDIBLE DIAGNOSTIC CODES</p> <ol style="list-style-type: none"> 1. LOW VOLTAGE 2. COMBUSTION BLOWER 3. LOSS OF FLAME 4. BURNER MAINTENANCE 5. GLOW PLUG 6. TEG OVER TEMPERATURE 7. OVER VOLTAGE 8. TIP-OVER 9. FIN TEMP SENSOR 10. TENT OVER TEMPERATURE </div>	<p>10</p>

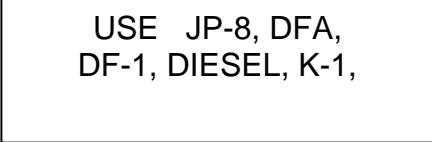
Table 3. SHC Labels and Instruction Plates – Continued.

<p>* Current Model Configuration Label</p> <div style="border: 1px solid black; padding: 10px; margin: 20px auto; width: 80%;"> <p style="text-align: center;">AUDIBLE DIAGNOSTIC CODES</p> <ol style="list-style-type: none"> 1. LOW VOLTAGE 2. COMBUSTION BLOWER 3. LOSS OF FLAME 4. BURNER MAINTENANCE 5. GLOW PLUG 6. TEG OVER TEMPERATURE 7. OVER VOLTAGE 8. TIP-OVER 9. FIN TEMP SENSOR 10. TENT OVER TEMPERATURE 11. NOT USED 12. LOW SYSTEM VOLTAGE </div>	<p>10 - Continued</p>
<div style="border: 1px solid black; padding: 10px; margin: 20px auto; width: 80%;"> <div style="display: flex; justify-content: space-between;"> <div style="width: 45%;"> <p>TO START:</p> <p>CONNECT DIESEL FUEL AND NECESSARY DUCT WORK TO HEATER, THEN POSITION ON/OFF SWITCH TO THE ON POSITION. HEATER IS OPERATING WHEN ONE OR MORE GREEN ADVISORY LIGHTS ARE ON.</p> </div> <div style="width: 10%; text-align: center;"> <p>ON</p>  <p>OFF</p> </div> <div style="width: 45%;"> <p>TO STOP:</p> <p>POSITION ON/OFF SWITCH TO OFF POSITION. HEATER IS SAFE FOR REFUELING OR RELOCATING AFTER ALL ADVISORY LIGHTS ARE OFF.</p> </div> </div> <div style="margin-top: 20px;"> <div style="display: flex; justify-content: space-between;"> <div style="width: 45%;"> <p>2 3 4 5</p> <p>1 2 3 4 5</p> <p>LOWER HIGHER</p> </div> <div style="width: 50%;"> <p><input type="radio"/> HEATER ON / ON - HOLD</p> <p><input type="radio"/> BATTERY CHARGING</p> <p><input type="radio"/> BATTERY CHARGED</p> <p><input type="radio"/> SYSTEM FAULT</p> <p><input type="radio"/> AT SETPOINT</p> </div> </div> </div> </div>	<p>11</p>

Table 3. SHC Labels and Instruction Plates – Continued.





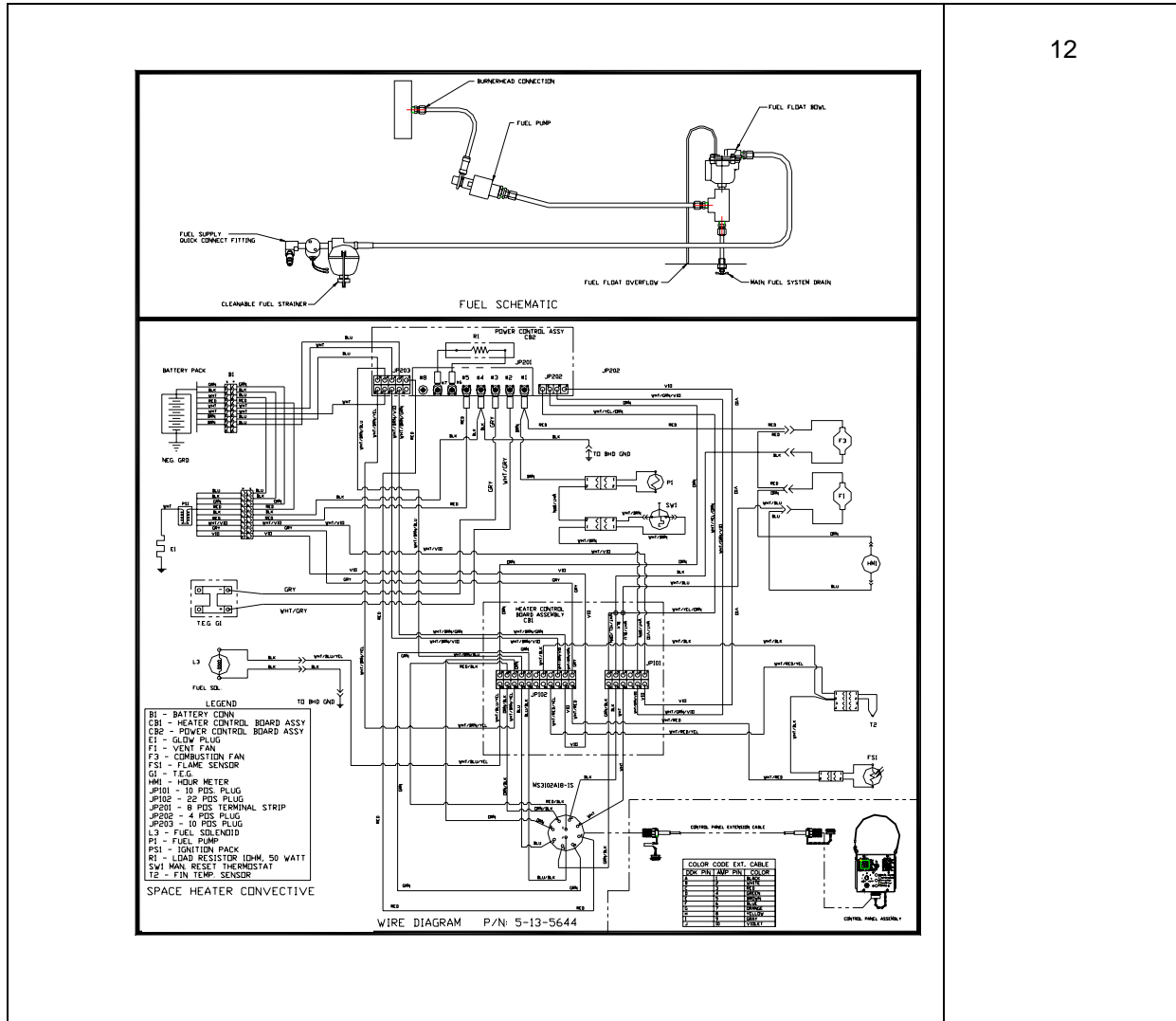
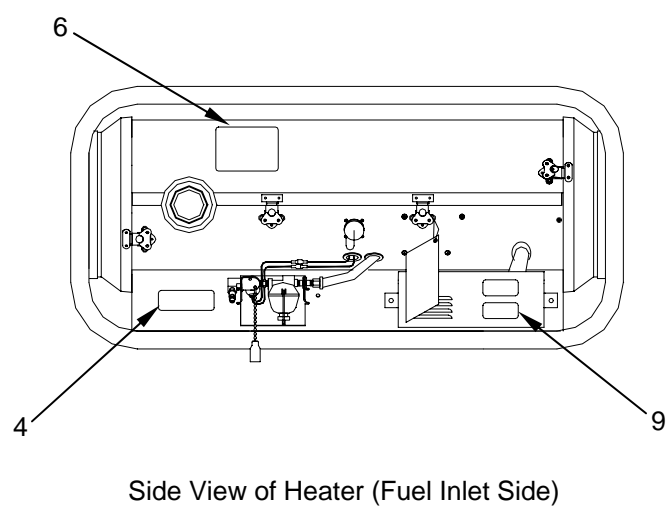
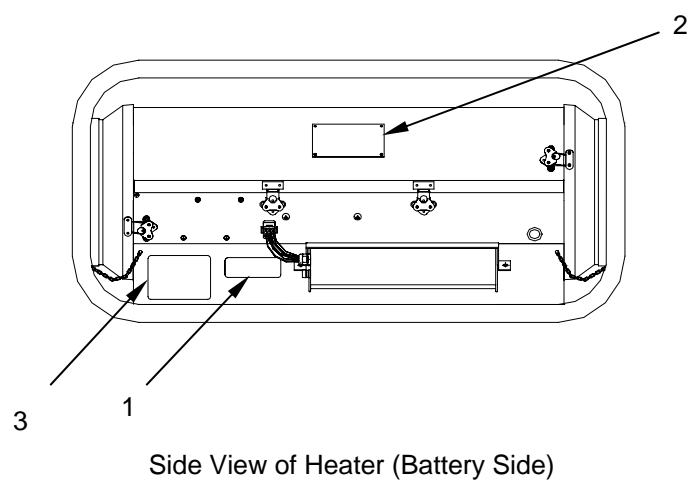
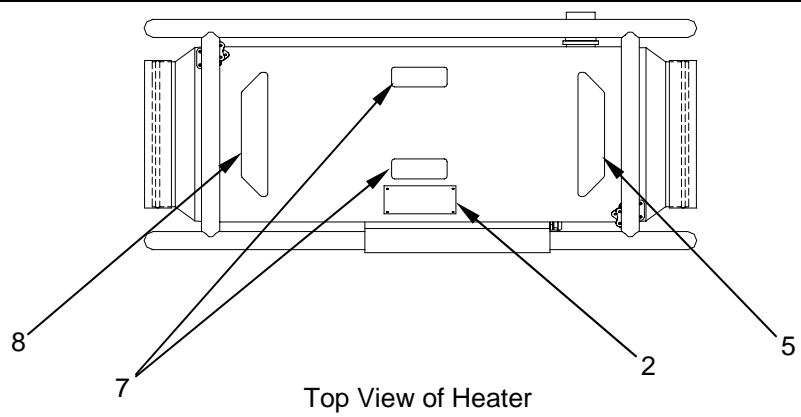
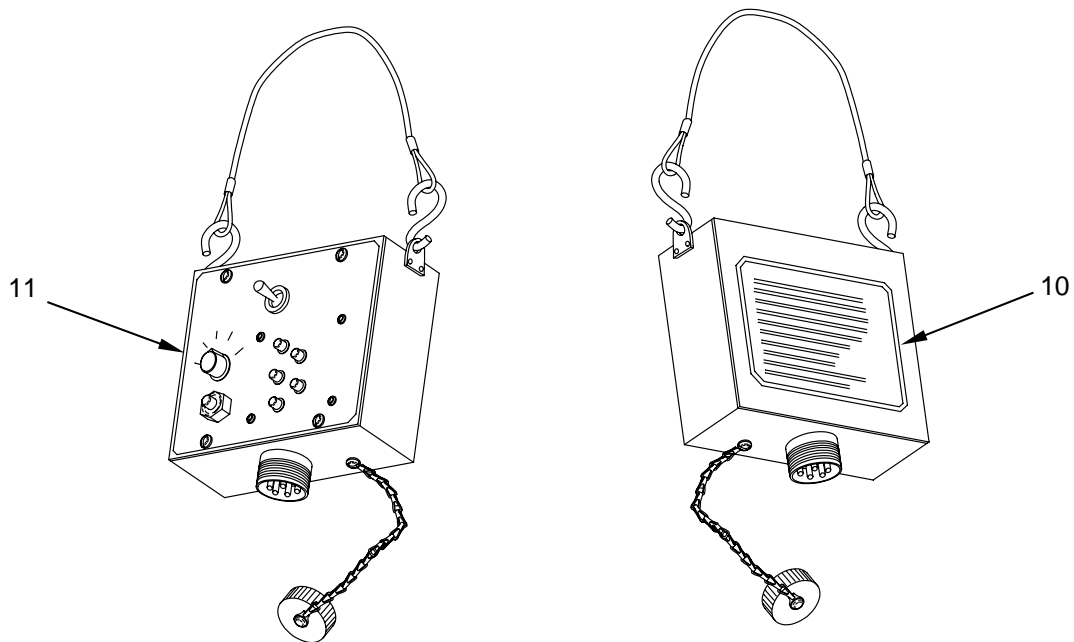

**SPACE HEATER, CONVECTIVE (SHC)
OPERATION UNDER USUAL CONDITIONS**

PREPARATION FOR USE

Unpacking and Inspection Upon Receipt. Inspect containers and packaging upon receipt for evidence of damage occurring in shipping. The heater package and its accessories were carefully inspected and securely packaged prior to shipment. If damage to the containers or packaging is found it is the shipper's responsibility.

Do not unpack a heater that is obviously damaged in shipment until the shipper is notified and has inspected the packaging. Notify your supervisor.

Remove heater package and accessories from shipping containers and packaging.

Inspect the heater package and accessories for completeness by comparing the contents against the description of the equipment found in the Components of End Item work package of this technical manual.

NOTE

Heater will not operate when tilt or grade is greater than 15 degrees, which is a 1.5-foot drop over a 10-foot span.

SPACE HEATER CONVECTIVE (SHC) TENT WALL MODIFICATION KIT (TWMK) INSTALLATION

In order to operate the Space Heater, Convective with the Command Post Shelter, tent duct tunnels must be present on one of the walls of the tent. The installation of the tent duct tunnels must be performed before using the Space Heater, Convective.

If these tunnels are not present on the shelter, the tent wall modification kit must be applied to the tent. Complete instructions for the installation of the tent wall modification are contained in the following section:

Tools Required:

- Cutting Tool (knife or razor blade).
- Marking Tool (pen, pencil, or marker).
- Cross-Tip Screwdriver.
- Punch (if available).

Components included with kit:

- 4 retaining rings [2 Cuff Rings (with fabric attached) and 2 Plain Rings].
- 9 bolts & 9 nuts.



NOTE

The entire assembly process can be done from inside the tent.

Determine location to install TWMK

1. To determine the proper location for the installation of the Tent Wall Modification Kit (TWMK), enter the tent and lift up the tent liner (if present) to expose tent wall.
2. Measure approx. 3 ¼ feet from the center of the tent towards a side wall.
3. Measure approx. 12 inches up from the floor and mark an "X."

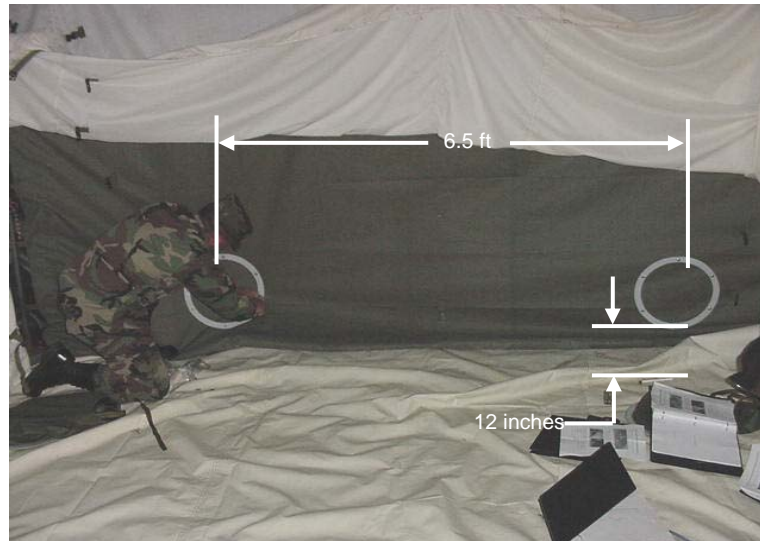

4. Repeat steps 2 & 3 for other side.
5. The distance between the two marked X's should be approx. 6 ½ feet.
6. Place a plain ring around the marked "X" on one side, (center "X" inside Plain Ring).
7. Using a punch or a cross-tip screwdriver, punch a hole through the top hole of the Plain Ring through the tent material.
8. Place a bolt through that hole to temporarily hold the plain ring in place onto the tent.
9. Continue to punch holes for the remaining five holes as you put in a bolt in each punched hole. (It's important that you put in a bolt after each punched hole to maintain alignment).



10. Once all bolts are in place, using the plain ring as a template, cut out a hole in the tent wall along the inside diameter of the ring (approximately 19" diameter hole).



11. Repeat steps 6 through 10 for the other hole location.
12. Once the large holes have been cut out, remove the plain rings and hardware from the wall.
13. Install a cuff ring where the plain ring was previously located on the inside tent wall with the fabric cuff pushed through to the outside of the tent.



14. Line up and install the bolts through the cuff ring and the tent wall. Use the cross-tip screwdriver to help in screwing the bolts through the fabric to the outside.
15. Squeeze and push the plain ring through the cuff ring to the outside.



16. Line up the plain ring with the protruding bolts.
17. Place and tighten the nuts (9 total) on the protruding bolts outside of tent so as to sandwich the tent wall between the 2 rings.
18. Repeat steps 13 through 17 for the other hole location.

NOTE

A successful completion should look comparable to the photo below.



SITE SELECTION CRITERIA (OUTSIDE THE TENT)**WARNING**

The Space Heater Convective weighs approximately 74 pounds (33.6 kg) without accessories. Two persons must carry the unit, lifting with your legs, not your back, to prevent injury. Failure to do so may result in serious back or other musculo-skeletal injuries.

**WARNING**

Small, portable, shelter heaters of this type are not designed to be moved during operation or before purge cycles are complete. Serious burn injury or death can occur if the heater assembly is moved while operating or before the HEATER ON/ON-HOLD advisory light goes OFF indicating the end of operation, post purge, and cool down cycle completion.

The space heater, convective site will be dictated by the location of the tent since the heater inlet **(1)** and outlet **(2)** ducts must be able to reach the tent duct tunnels **(3)**.

NOTE

Heater will not operate when tilt or grade is greater than 15 degrees, which is a 1.5-foot drop over a 10-foot span.

The heater site must be as level as possible (heater will not start or, operate if the slope is greater than 15 degrees), and free of combustible material (e.g. dried twigs, leaves, etc.). If snow is present, it should be removed from the area immediately beneath and around the heater.

The site should be selected so that the heater will be positioned at least 2 feet (61 cm) from combustibles, including the tent wall.



BEFORE OPERATION PMCS

Perform the "Before Operation PMCS" on all SHC system components as outlined in WP 0010 00, prior to preparing the heater for use. All scheduled maintenance must be performed on the heater and its associated equipment prior to use.

Positioning the Heater Outside Tent. Place heater on the side of the tent that has the tent duct tunnels (1). The heater should be a minimum of 2 feet (61 cm) from tent walls (2). Position the heater (3) so that the combustion exhaust outlet (4) is directed away from the tent wall (2) and the two supplied five foot (152 cm) long ducts (5) can be connected to both the heater (3) and the tent (2). Do not install the ducts or connect the fuel supply at this time, simply place the heater in position.

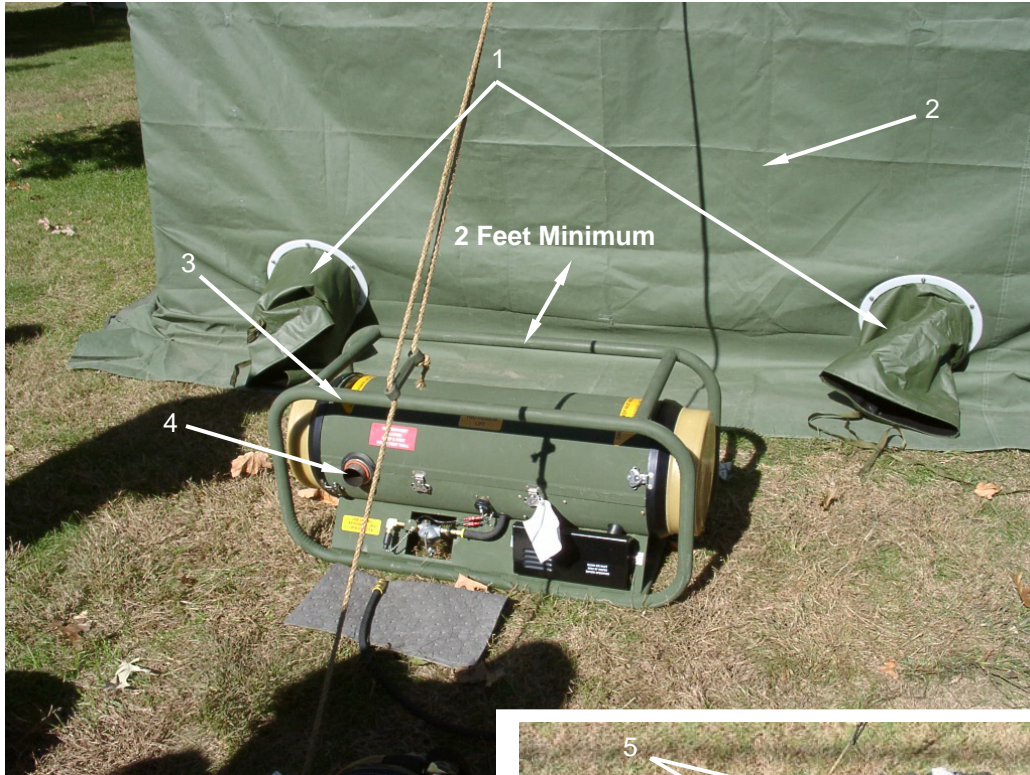

PREPARING A FUEL SUPPLY SITE

Select a fuel supply site that is level, free of debris and open flame, at least seven feet (2.13 meters) from the tent, and a minimum of five feet from heater.

NOTE

A piece of petroleum absorbent material should be placed where the fuel can and fuel can stand will be installed as well as under the fuel quick disconnect connector in order to catch any fuel that may spill. Additional commercial products are available to contain large spills. Soiled absorbent material should be discarded in accordance with local environmental regulations.

Route the fuel supply hose from the heater to the fuel supply location to gauge where the fuel supply site is best located. Place a petroleum absorbent mat where the fuel can stand will be set up.

FILL FUEL CAN WITH FUEL AND INSTALL FUEL CAN ADAPTER

Heater Assembly Fuel Selection



WARNING

Gasoline, JP-4, Used Motor Oil, Solvents, Fuel Mixtures, or other unauthorized fuels should NOT be used with the Space Heater, Convective under any circumstance. Only JP-8 or an approved alternate fuel as detailed in WP 0002 00 and WP 0001 00 Table 2 may be used. Failure to observe fuel requirements could cause damage to the heater assembly, fire danger, potential explosion, and injury or death to personnel within or around the tent and the heater assembly.

Refer to Table 1 to determine the appropriate fuel to use at the ambient temperature. JP-8 is the preferred fuel for all temperature conditions because it burns cleaner than other approved fuels and will provide the best heater performance, reducing the frequency of required burner maintenance. Use of diesel fuel will require regular burner cleaning every 250 operating hours.

Table 1. Fuel Selection vs. Outside Temperature.

Primary Fuel	Ambient Temperature	Specification
JP-8	Above -60°F (-51.1°C)	MIL-DTL-83133E
Alternate Fuels	Ambient Temperature	Specification
K-1 (Kerosene)	Above -25°F (-31.7°C)	
DF-A	Above -60°F (-51.1°C)	A-A-52557A
DF-1	Above -25°F (-31.7°C)	A-A-52557A
JP-5	Above -25°F (-31.7°C)	MIL-DTL-5624U
DF-2	Above +20°F (-6.7°C)	A-A-52557A

Install Fuel Can Adapter. At the fuel supply site, install a fuel can adapter on a full fuel can as follows:



WARNING

Fuel can adapter kit must be fully seated to prevent fuel leakage. Clean up all fuel spills. Failure to comply may result in serious injury or death.

NOTE

Leaking or spilled fuels will harm the environment. Follow all local requirements when cleaning up all fuel spills.

1. Remove cap **(1)** from mouth **(2)** of fuel can **(3)**, and replace with gravity feed adapter **(4)**. Screw the adapter into the fuel can securely.
2. Attach male end **(5)** of fuel supply hose **(6)** to gravity feed adapter fitting **(7)**. Set the assembled fuel can aside.
3. At the fuel supply site, set up fuel can stand with fuel can **(3)** level or slightly above heater as detailed in the next section.

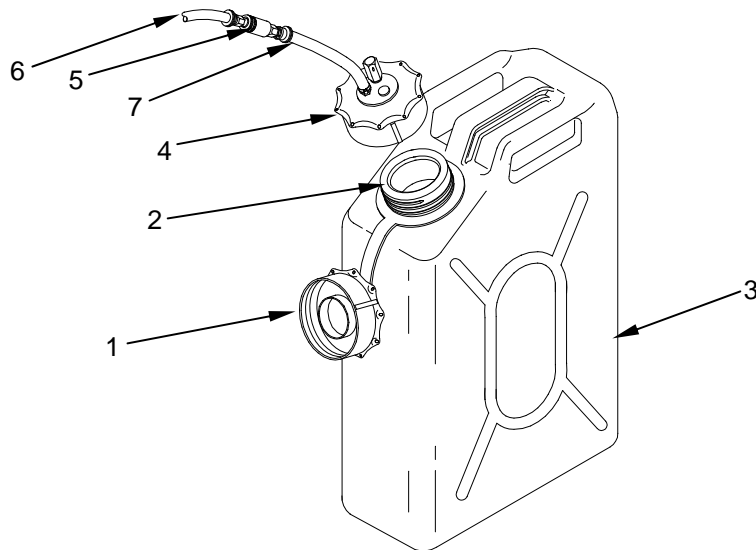

Assemble Fuel Can Stand. Select a site for the fuel can stand that is a minimum of 5 feet (1.5 m) but no more than 8 feet (2.4m) from the fuel quick disconnect connector on the heater.

No heat or flame sources, other than the heater, shall be within 8 feet (2.4 m) of fuel can stand. Set up the fuel can stand in accordance with the instructions detailed below. For convenience in the field, an instruction card is attached to the fuel can stand.



WARNING

Always place fuel can and stand in well-ventilated area far away from the SHC, open flames, and other potential ignition sources. Clean up all fuel spills. Failure to comply could result in serious injury or death.

NOTE

Leaking or spilled fuels will harm the environment. Follow all local requirements when cleaning up all fuel spills.

1. Insert the bottom leg assembly **(1)** into the top leg assembly **(2)** until each leg is locked in place. Orient each bottom leg so that the stabilizing straps **(3)** are positioned toward the inside of the stand. Ensure that the straps are not twisted.

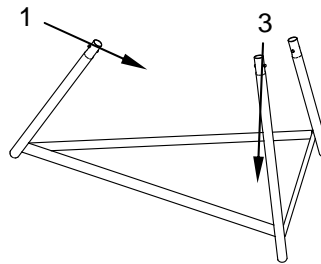
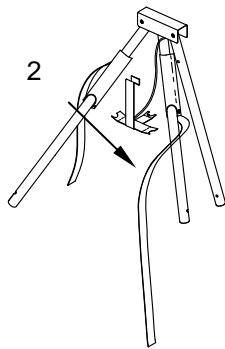

- Spread the assembled leg assembly (4) until the stabilizing straps (3) are fully extended and the stand is stable.

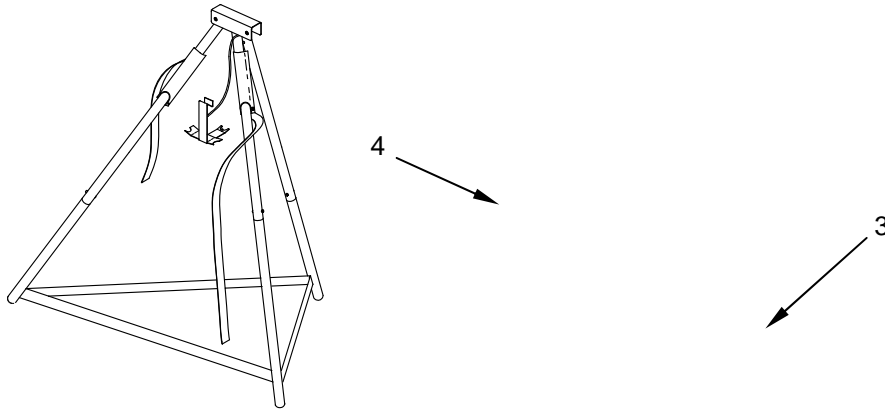

- Lower the left (5) and right (6) support arms so that each is at a right angle to its attached leg. Place the tripod brace (7) under the top bracket (8) of the stand and clip into position over the front of the top bracket.

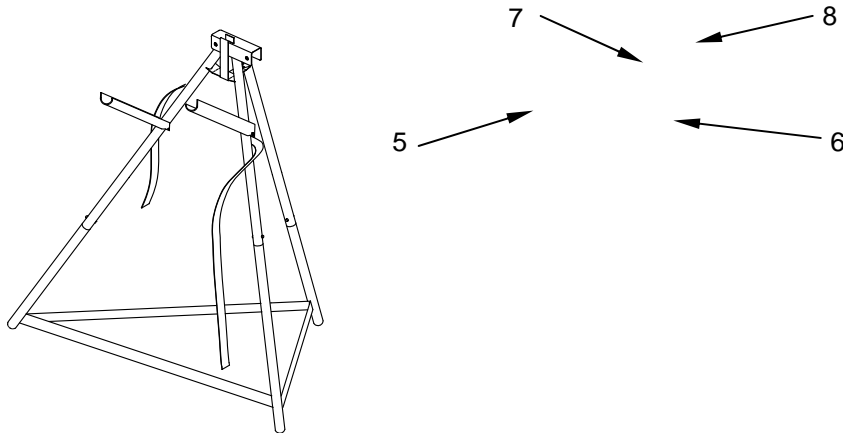

- Invert the fuel can with installed fuel can adapter (9) and mount on the assembled fuel can stand so that the gravity feed adapter (10) faces the ground. Slide the right support arm (8) through the handle (11) of the fuel can. Wrap the left support strap (12) over the bottom of the fuel can (9). Feed the right support strap (13) through the fuel can handle (11), up across the front of the fuel can body, and over the left support strap (12). Secure the right strap (13) to the left strap. The strap helps secure a partially filled fuel can to the fuel stand during windy conditions.

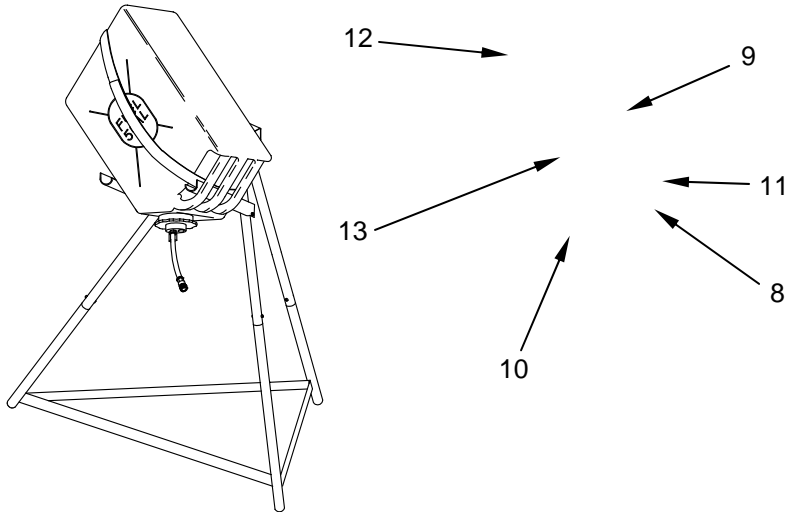

If any fuel leaks occur, refer to WP 0009 00 entitled "Troubleshooting."

HEATER SETUP**WARNING**

Do not operate the space heater in an enclosed area and direct the exhaust outlet away from shelters or personnel. Carbon monoxide is a colorless, odorless, gas that can kill you. Carbon monoxide is present in the exhaust of fuel-burning heaters and internal combustion engines. Dangerous levels of carbon monoxide will occur if operated in an enclosed area. Breathing carbon monoxide produces symptoms of headache, dizziness, loss of muscular control, a sleepy feeling, and unconsciousness or coma. Follow all the precautions/warnings in this TM. Failure to observe this warning may result in brain damage or death.

**WARNING**

Combustible material must be kept at least 2 feet (61 cm) away from the heater during operation.

**WARNING**

Small, portable, shelter heaters of this type are not designed to be moved during operation or before purge cycles are complete. Serious burn injury or death can occur if the heater assembly is moved while operating or before the HEATER ON/ON-HOLD advisory light goes OFF indicating the end of operation, post purge, and cool down cycle completion.

CAUTION

Always keep fuel lines and fuel cans clean and free of dust, dirt, and water. Make sure fuel lines lie flat without kinks or loops that could trap air in the lines and slow the fuel flow to the heater. Ensure all ducts and pipes are clean and free of dirt or obstructions prior to attaching them to the heater.

NOTE

The heater should run for about 14 hours on five gallons (18.9 L) of fuel.

Connect In-Tent Controller Assembly To In-Tent Controller Cable. Make sure the in-tent controller assembly connector **(1)** and the in-tent controller assembly cable connectors **(2)** are clean and are not damaged. Connect the cable connector **(2)** to the in-tent controller assembly **(1)**.

Remember that the two connectors are “keyed” together and will only fit together one way. Tighten connector securely.

Ensure that the ON/OFF switch on the in-tent controller is in the OFF position.

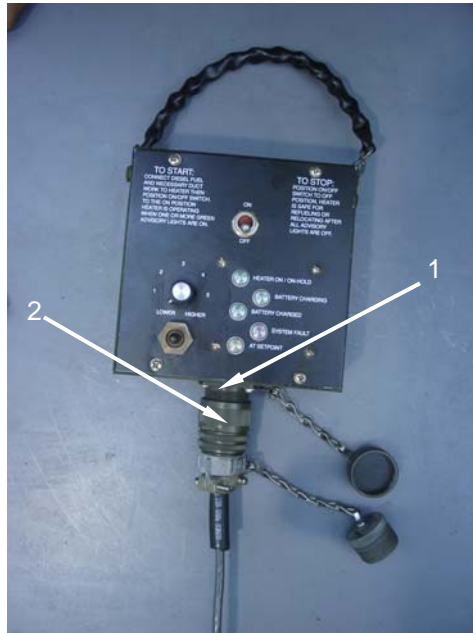

Routing the In-tent Controller and Cable through the Tent Duct Tunnel.

NOTE

Ensure that the ON/OFF switch on the in-tent controller assembly is in the OFF position before connecting the in-tent controller cable to the heater. If the switch is in the ON position, the heater will start as soon as the cable is connected to the heater.

The in-tent controller with attached cable **(1)** is routed through the tent duct tunnel **(2)** nearest the breathable air inlet end **(3)** of the heater from outside the tent. The breathable air inlet **(3)** is the end of the heater opposite the exhaust **(4)** and is labeled on the top of the heater.

To route the in-tent controller and cable **(1)** into the tent, open the end of the tent duct tunnel **(2)** nearest the breathable air inlet **(3)** of the heater and reach into the tent duct tunnel **(2)** placing the in-tent controller with attached cable **(1)** into the interior of the tent. Be sure that the cable is not crimped, tangled, or positioned in a way that could cause the cable to become damaged during heater operation.

Once the in-tent controller is positioned inside the tent, attach the connector **(5)** at the opposite end of the in-tent controller cable to the electrical connector **(6)** on the heater assembly. Tighten the connector securely.

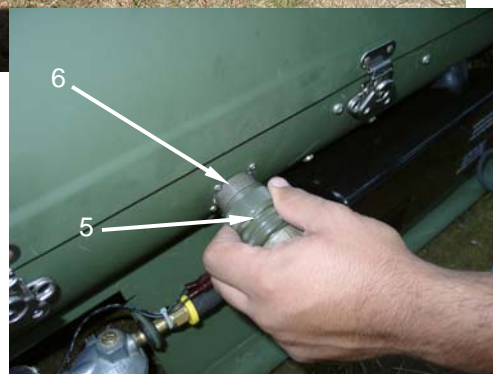

Positioning the In-tent Controller Inside the Tent. Once inside the tent, locate a suitable place within the tent to hang the in-tent controller assembly (1).

A suitable location would be as far away from the outlet duct as possible and not be directly in line with either of the heater ducts openings (2). The In-tent Controller should also be placed at eye level if possible for ease of use and for accurate temperature recognition.

Hang the in-tent control assembly from a horizontal tent member or clip (3).





CONNECT FUEL HOSE TO HEATER



WARNING

Gasoline, JP-4, Used Motor Oil, Solvents, Fuel Mixtures, or other unauthorized fuels should NOT be used with the Space Heater, Convective under any circumstance. Only JP-8 or an approved alternate fuel as detailed in WP 0002 00 and WP 0001 00, Table 2 may be used. There is potential for an explosion. Failure to comply may result in injury or death to personnel in or around the tent and the heater assembly.

CAUTION

Only use JP-8 or an approved alternate fuel as detailed in WP 0002 00 and WP 0001 00, Table 2 with the Space Heater, Convective. An inappropriate fuel may adversely affect the heater operation. Failure to observe fuel requirements could cause damage to the space heater.

1. Before connecting the fuel hose **(1)** to the fuel quick disconnect connector **(2)**, position a section of petroleum absorbent mat **(3)** under the fuel quick disconnect connector **(2)**.

2. Remove the protective dust cap (8) and store it raised up on the fuel quick disconnect connector (2) to keep dirt out of the fuel system.
3. Attach the quick disconnect connector (4) on the end of the fuel hose (1) coming from the fuel can (5) to the fuel quick disconnect (2) on the heater assembly. Make sure the hose lies flat and is not kinked or looped.
4. Ensure that the battery pack connector (6) is connected to the lower housing assembly battery connector (7).

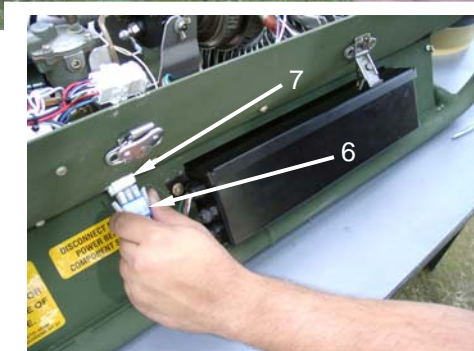
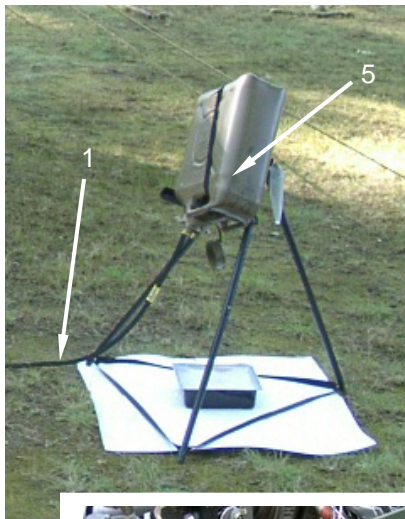

INSTALLING THE AIR SUPPLY AND RETURN DUCTS

General. Two air ducts, 8 feet in length and 10.5 inches in diameter, connect to the inlet and outlet ends of the heater and move air from the interior of the tent through the heater and back to the interior of the tent. Although the two ducts appear to be identical, they differ in that one is specifically designed to move unheated air from the tent to the heater (the air supply duct) and the other is designed to move heated air from the heater to the tent (the air return duct).

The two ducts can be differentiated from one another by observing the direction of the air flow tags and the location of the debris grill. The air supply duct **(1)**, which conducts cool, breathable air from the tent to the breathable air inlet of the heater has an air flow tag with a directional arrow that points from the end of the duct with the debris grill toward the open end of the duct. An inspection of the interior of the air supply duct shows that the end with the debris grill has a SILVER lining.

The air return duct **(2)**, which conducts heated air from the Space Heater Convective to the tent, has an air flow tag with a directional arrow that points from the open end of the duct toward the end of the duct with the debris grill. An inspection of the interior of the air return duct shows that the end with the debris grill has a GREEN lining.

If the air flow tags are damaged or missing from the duct(s), one can also tell the difference between the two ducts by inspecting the interior. Looking in one end of a duct, it can be seen that the interior has a silver colored lining. Reversing the duct and looking in the opposite end of the duct, one will observe that the duct has a green colored lining. This is due to the fact that the interior of the duct is designed to promote air flow within the duct from the silver lined end to the green lined end. If the debris grills should ever be separated from the ducts, they can be properly assembled by placing one debris grill at the green end of the duct and one debris grill at the silver end of the other duct.



Installing Debris Grills in Air Supply and Return Ducts. When the heater is shipped initially, the debris grills (1, 2) are not installed in the end of the air supply (3) or air return (4) ducts but must be installed before the heater can be used. To install the debris grill in the air supply duct (3), inspect the interior of each duct and note that one end of the duct has a green lining and the other end has a silver lining as described in the previous section entitled "General."

1. Install a debris grill (2) (with the grill facing out) into the silver lining end of one of the ducts. Secure the debris grill in the end of the duct with the strap (5) at the end of the duct. This duct will be the air supply duct (3) that carries cool air from the tent into the breathable air inlet end of the heater.
2. Install a debris grill (1) (with the grill facing out) into the green lining end of the remaining duct (4). Secure the debris grill in the end of the duct with the strap (6) located at the end of the duct. This duct will be the air return duct (4) that carries heated air from the heated air outlet end of the heater and into the tent.



Installing the Air Supply and Return Ducts

1. Remove dust covers **(1)** from heater assembly duct adapters **(2)**.
2. Ensure that each of the duct adapter assemblies are securely attached to the heater housing assembly by two fasteners **(3)**. The fasteners must be tightened securely and in the locked position.



WARNING

During heater operation, air leaving the heated air outlet of the heater and passing through the heated air inlet duct (with debris grill) may exceed 220°F (104°C). Make sure tent personnel are aware of burn hazards and equipment hazards presented by the heated air and the debris grill. To ensure proper air flow, air duct color code inspection is critical.

3. Locate the heated air return duct **(4)**. The heated air return duct **(4)** will have an air flow arrow pointing toward the debris grill **(5)**.
4. Ensure inside and outside of duct and the debris grill are free of damage, dirt, and obstructions prior to attachment to the heater assembly.
5. Insert the debris grill end **(5)** of the duct into the tent duct tunnel **(6)** closest to the exhaust outlet end **(7)** of the heater as indicated by the label "Heated Air Outlet" on the upper housing assembly.
6. Secure the tent duct tunnel tie straps **(8)**. Do not secure the straps so tightly that the air flow within the duct is restricted.
7. Attach the open end of the duct to the duct adapter **(9)** on the outlet side of the heater. This is the end of the heater closest to the exhaust outlet **(7)**. Tighten the duct strap **(10)** securely on the duct adapter **(9)**.
8. Locate the air supply duct **(11)**. The air supply duct **(11)** will have an air flow arrow pointing away from the debris grill.
9. Ensure inside and outside of duct and the grill are free of damage, dirt, and obstructions prior to attachment to the heater assembly.

10. Insert the debris grill end **(12)** of the duct into the tent duct tunnel **(13)** closest to the breathable air inlet of the heater as indicated by the label "Breathable Air Inlet" **(14)** on the upper housing assembly.
11. Secure the tent duct tunnel tie straps **(15)**. Do not secure the straps so tightly that the air flow within the duct is restricted.
12. Attach the open end of the duct **(16)** to the duct adapter **(17)** on the breathable air inlet side of the heater. This is the end of the heater farthest from the exhaust outlet **(7)**.
13. Tighten the duct strap securely on the duct adapter **(17)**.

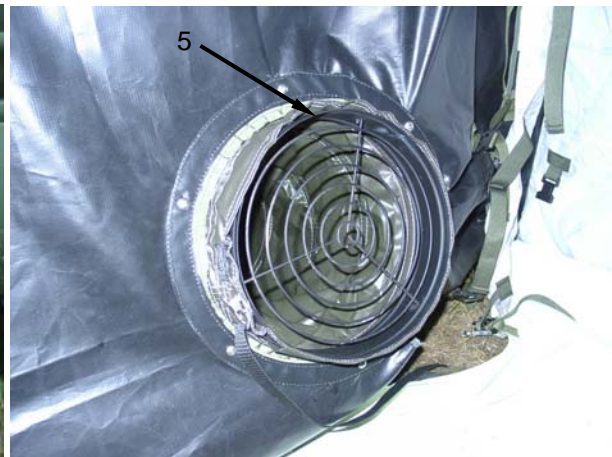

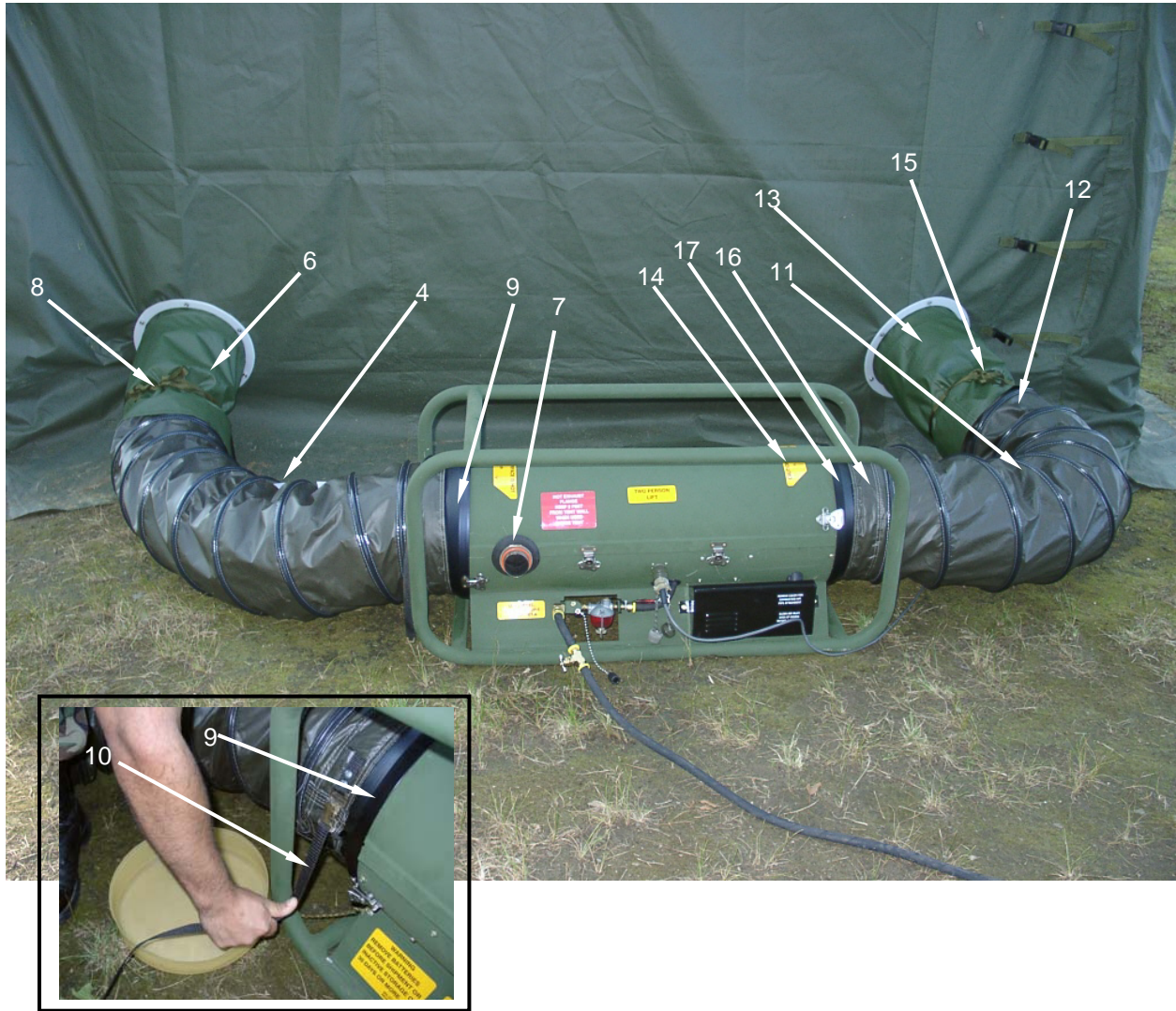

FINAL CHECKS BEFORE OPERATION**WARNING**

Gasoline, JP-4, mixed fuels, or solvents must not be used with the Space Heater, Convective under any circumstance. Only JP-8 or an approved alternate fuel as detailed in WP 0002 00 and WP 0001 00, Table 2 may be used. There is potential for an explosion. Failure to comply may result in injury or death to personnel in or around the tent and the heater assembly.

Make sure that the fuel hose leading from the fuel can to the heater is not kinked or looped and lies flat on the ground. Make sure all fuel connections are correct, secure, and do not leak at the gravity feed adapter or fuel quick disconnect connector at the heater.

The heater assembly is now ready for operation.

END OF WORK PACKAGE

**SPACE HEATER, CONVECTIVE (SHC)
OPERATING UNDER USUAL CONDITIONS**

OPERATING THE CONVECTIVE SPACE HEATER

This work package has information and instructions for startup, operating, refueling, shutdown, and emergency shutdown of the heater.

PREPARATION FOR STARTING

Before operating the heater, you must be familiar with the heater controls. Refer to WP 0004 00 entitled "Controls, Indicators and Labels/Instruction Plates," to review the functions of controls and indicators before operating the heater.

This heater is designed to operate with minimal operator intervention. Once the heater has been put into operation, the only action required of the operator is adjusting the LOWER-HIGHER knob (1) (thermostat) on the in-tent controller assembly (2) if the temperature in the tent becomes too hot or too cold.

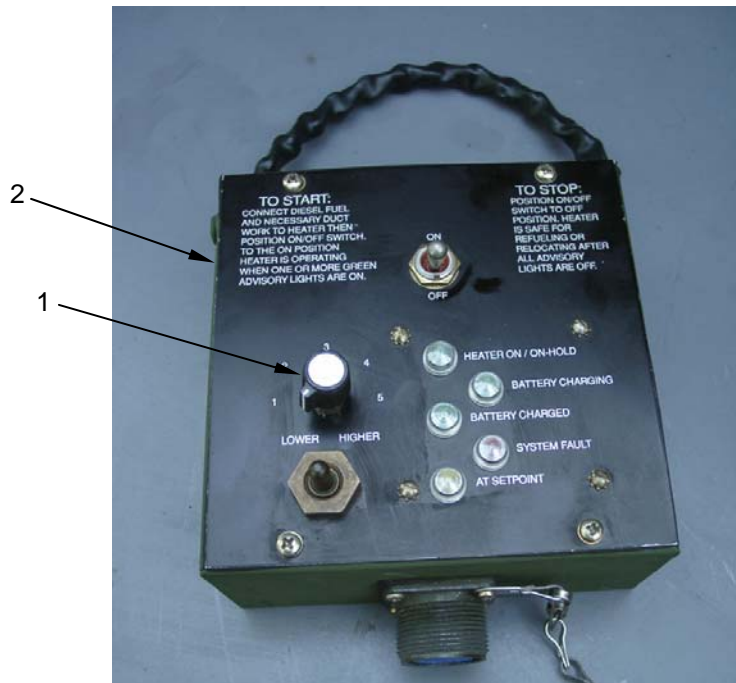



WARNING

Do not move heater during operation or before purge cycles are complete. Serious injury, skin burns, or death can occur if the heater assembly is moved while operating or before the HEATER ON/ON-HOLD advisory light goes OFF indicating the end of operation, post purge, and cool down cycle completion.

Do not touch metal components during operation. Some metal components of the heater assembly become extremely hot, such as the debris grill on the outlet duct, the upper and lower heater housing assemblies, combustion exhaust pipe, etc., Contact with bare skin can cause severe burn injuries. Failure to comply may result in serious injury to personnel.

Make sure the heater assembly has been properly set up and the appropriate fuel selected as detailed in Table 1 of WP 0005 00.

Make sure the fuel can is full before starting. If the fuel can is empty, refer to the section of this work package entitled "Refueling the Convective Space Heater."

STARTING THE HEATER. To start the heater, switch the ON/OFF switch (1) on the in-tent controller (2) to the ON position. The green HEATER ON/ON-HOLD advisory light (3) will illuminate and the pre-purge cycle will begin. The heater takes a few minutes to bring glowing warm air into the tent. Table 1 below describes approximate times of starting functions.

Table 2. Approximate Times of Starting Functions.

Function	Elapsed Time from Actuation of ON Switch	Comments
Switch on	0 seconds	
Power on self-test	6 seconds	Continuous beep from control box with all lights on. All fans come on momentarily.
Glow plug heating	12 seconds	Glow plug comes on.
Fuel pump on	1 minute 5 seconds	Recognized by audible slow clicking.
Combustion air blower on	1 minute 27 seconds	Should see puff of white exhaust. Combustion starts.
Circulating fan on	Approximately 5 minutes 30 seconds	Heat begins to exit heater outlet. The colder it is, the longer it takes.
Battery Charging light on	Approximately 10 to 12 minutes	The battery begins charging.
Battery Charged light on	Approximately 30 to 40 minutes	May take as long as 2 hours, depending on charge level of battery before start.

NOTE

If the heater does not start after three consecutive start attempts, go to the Operator Troubleshooting Procedures (WP 0009 00). An excessive number of failed start attempts, without a recharge cycle, may drain the battery.

NOTE

The heater assembly can be shut down in a normal manner at any time by placing the ON/OFF switch to the OFF position. However, to insure both a fully charged battery for subsequent operation and a longer battery life, the heater assembly, whenever possible should be allowed to run until the green BATTERY CHARGED light **(4)** illuminates.

When first setting the LOWER-HIGHER control knob **(5)**, on the in-tent controller assembly **(2)**, it should be set it to its highest setting. When the tent has reached a comfortable temperature, turn the LOWER-HIGHER knob down until the amber AT SETPOINT light **(6)** illuminates. The heater control assembly will then regulate to this temperature.

The heater will run at full power until the battery charging light comes on. If the red SYSTEM FAULT light **(7)** illuminates, the heater will enter shut down mode and the SYSTEM FAULT light will flash from 1 to 12 times and an audible series of tones indicating a diagnostic code. These diagnostic codes provide the user with information regarding the nature of the fault. In some cases the problem may be corrected by the operator and a re-start may be attempted. If the problem is of a more serious nature and cannot be corrected by the operator, the heater should be referred to Unit Maintenance for repair. Refer to WP 0009 00 entitled "Troubleshooting" for a complete discussion of the various diagnostic codes.

NOTE

The heater will operate at full power until the Battery Charging Light illuminates. Once the light comes on, the LOWER-HIGHER control can be used to regulate heater output.

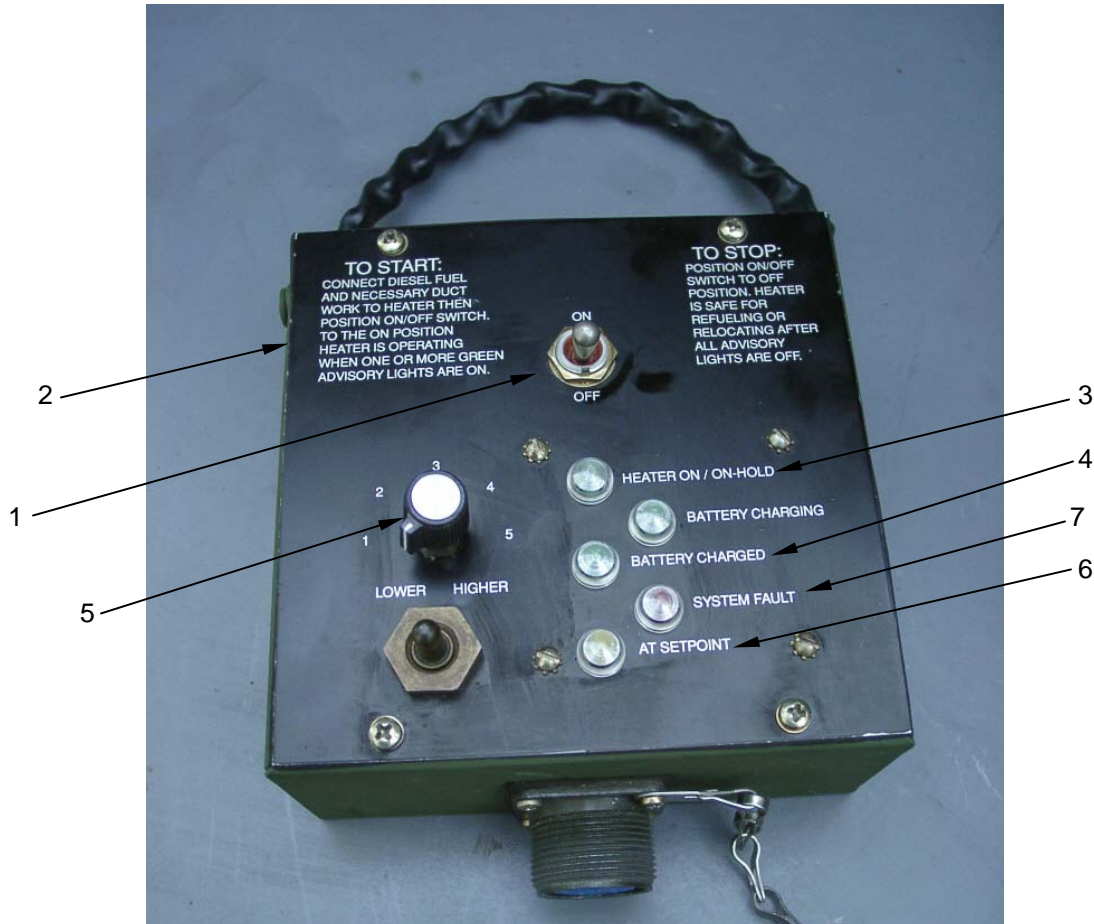

Once the ON/OFF switch on the in-tent controller assembly has been placed in the ON position, the HEATER ON/ON-HOLD advisory light is lit and the heater is in one of the following modes:

Pre-purge. During pre-purge, the combustion air blower assembly and the heated air blower assembly fan operate to clear any fumes from the heater.

Normal operation. The combustion air blower assembly and the heated air blower assembly fan continue to operate during normal operation to circulate the heated breathable air to the tent and to exhaust combustion fumes.

On-hold. In the HEATER ON/ON-HOLD mode, the heater does not heat but automatically begins heating in response to either changes in the tent temperature or changes to the LOWER/HIGHER setting on the in-tent controller assembly.

STOPPING THE HEATER

When the ON/OFF switch (1) is placed in the OFF position, the green HEATER ON/ON-HOLD advisory light (2) will go out and the fuel supply is shut off via the fuel solenoid valve; however, the combustion blower assembly and heated air blower fan continue to operate as the heater control assembly goes to the post-purge mode. The fans can be heard as they continue to run during the post-purge cycle.



WARNING

Do not move or refuel the heater, or remove ducts or pipes, until all fans have stopped running. Small, portable, shelter heaters of this type are not designed to be moved during operation or before purge cycles are complete. Serious burn injury or death can occur if the heater assembly is moved while operating or before the HEATER ON/ON-HOLD and cool down cycle completion.

Do not touch metal components during operation. Some metal components of the heater assembly become extremely hot, such as the debris grill on the outlet duct, the upper and lower heater housing assemblies, combustion exhaust pipe, etc., Contact with bare skin can cause severe burn injuries. Failure to comply may result in serious injury to personnel.

Complete heater shutdown is indicated by the stopping of the combustion blower assembly and heated air blower fan. The remaining advisory lights will extinguish as each heater sequence that the respective lights monitor ceases operation.



REFUELING WITH THE SAME FUEL**WARNING**

Gasoline, JP-4, mixed fuels, or solvents must not be used with the Space Heater, Convective under any circumstance. Only JP-8 or an approved alternate fuel as detailed in WP 0002 00 and WP 0001 00, Table 2 may be used. There is potential for an explosion. Failure to comply may result in injury or death to personnel in or around the tent and the heater assembly.

Do not refuel near open flame or other ignition sources. Only refuel in a well-ventilated area. Fuels are toxic and flammable. Wear protective goggles, avoiding contact with skin and clothes, and don't breathe vapors. If contact with eyes or skin is made, immediately flush with clean water and seek medical attention for eyes immediately. Failure to comply may result in serious injury to personnel.

Always place fuel can and stand in well-ventilated area as far away from open flames and other potential ignition sources as possible. Fuel spills must be cleaned up in accordance with local requirements.

Always switch heater control to the OFF position and wait until the blower fans stop and all advisory lights go out before beginning a refueling operation.

CAUTION

Always keep fuel hoses and fuel cans clean and free of dust, dirt, and water. Make sure fuel hoses lie flat without kinks or loops that could trap air in the lines and slow the fuel flow to the heater.

NOTE

The heater should run for about 14 hours on five gallons (18.9 L) of fuel.

1. Place the ON/OFF switch **(1)** of the in-tent controller assembly **(2)** in the OFF position or verify that it is in the OFF position.
2. If the heater assembly has been operating, allow it to complete the post-purge mode and make certain that all advisory lights **(3)** are off.

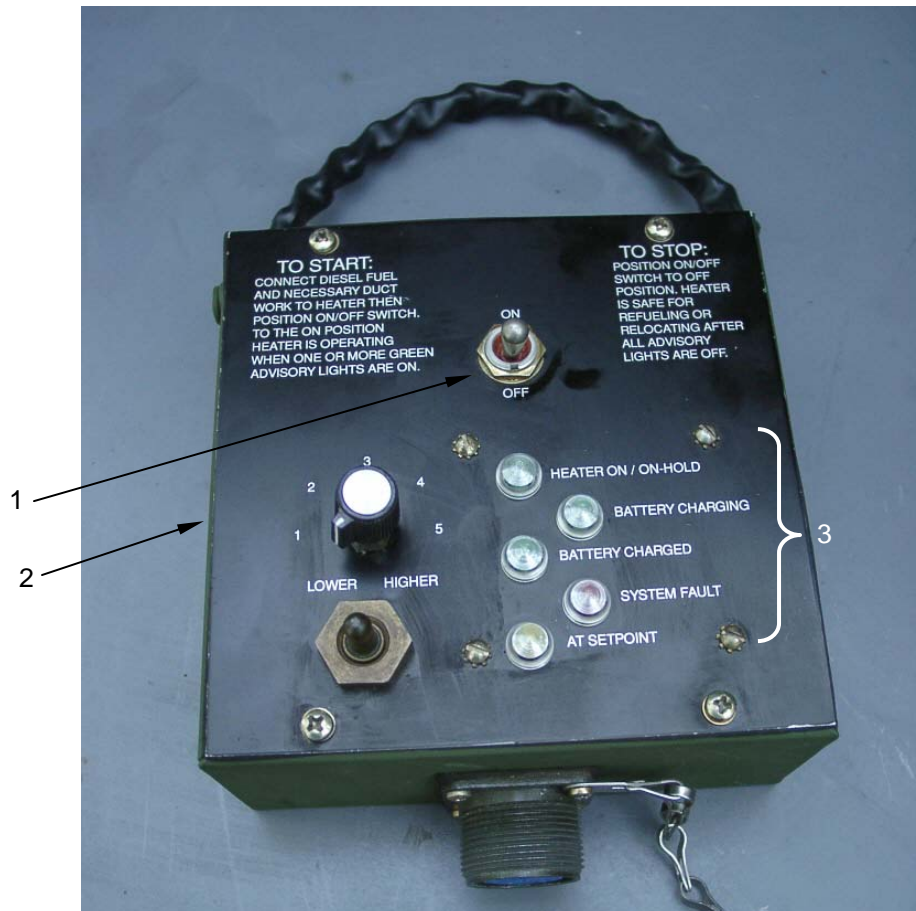

3. When the blower fans stop at the end of the post-purge mode, remove fuel can **(1)** from fuel can stand **(2)**.
4. Loosen and remove the fuel can adapter **(3)** and place it on the absorbent mat **(4)**.
5. Make sure all components of the fuel system are clean and free of dirt and damage that could contaminate the fuel supply or cause leakage.
6. If the expected ambient temperatures do not require a fuel change, fill the fuel can with the same fuel selected previously. Refer Table 2 of WP 0001 00 for fuel selection information. If the expected ambient temperatures require a fuel change, refer to the section of this work package entitled "Refueling with a Different Fuel."
7. Install fuel can adapter **(3)** onto fuel can **(1)**. Tighten securely.
8. Place fuel can onto the fuel can stand assembly **(2)** and strap in place in accordance with tag attached to stand assembly or procedures outlined in WP 0005 00 entitled "Assemble the Fuel Can Stand."

9. Make sure fuel connections are tight and that there are no fuel leaks.
10. Make sure fuel hose **(5)** lies flat on the ground and is not looped or kinked.
11. Heater assembly is now ready for operation. Make sure heater setup has not been changed, ducts and pipes are properly positioned, and heated air is directed in a safe manner. See applicable setup instructions in this section if in doubt as to existing setup.
12. If heat is desired, place heater ON/OFF switch in the ON position and verify that HEATER ON/ON-HOLD light is lit.

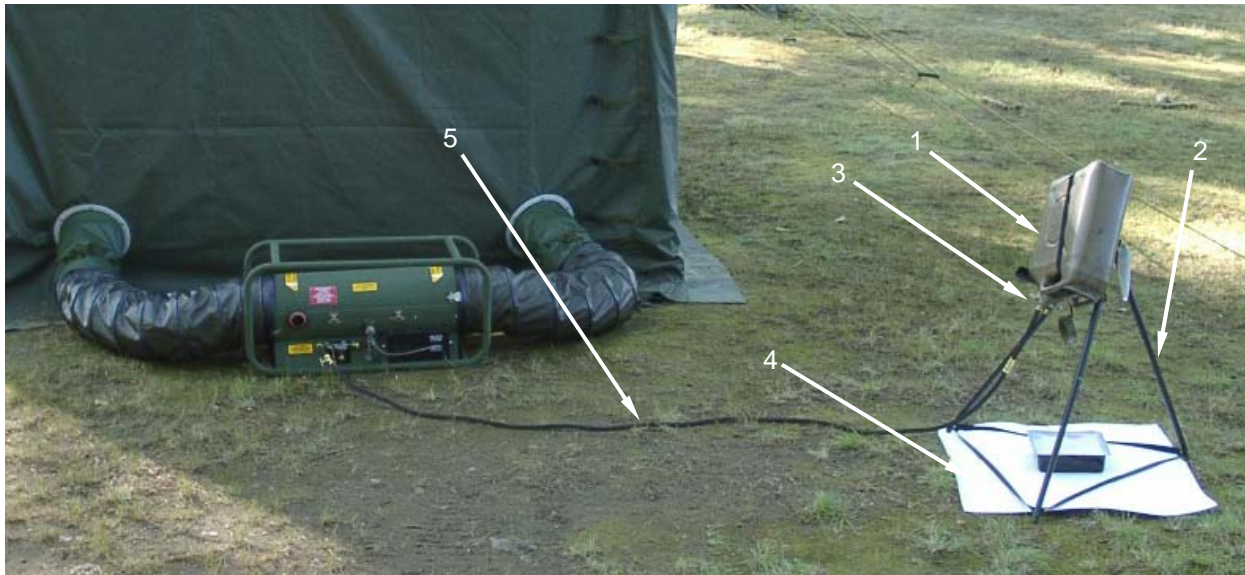

REFUELING WITH A DIFFERENT FUEL

When changing fuel types, all existing fuel must be drained from the fuel supply system as detailed in the section to follow. Also, the heater must be operated through a minimum of one charging cycle to work the new fuel through the system. A charging cycle is performed **after** the system has been refueled with a different fuel.

A charging cycle starts when the heater ON/OFF switch **(1)** is moved to the ON position and ends when the BATTERY CHARGED light **(2)** comes on. This must be accomplished to make sure that all the old fuel is burned during heater operation and the only fuel remaining in the heater fuel system is the new fuel type.





WARNING

Gasoline, JP-4, mixed fuels, or solvents must NOT be used with the Space Heater, Convective under any circumstance. Only JP-8 or an approved alternate fuel as detailed in WP 0002 00 and WP 0001 00 Table 2 may be used. Failure to observe fuel requirements could cause damage to the heater assembly, fire danger-potential explosion, and injury or death to personnel within or around the tent and the heater assembly.

Fuels are toxic and flammable. Do not refuel near open flame or other ignition sources. Only refuel in a well-ventilated area. Wear protective goggles, avoiding contact with skin and clothes, and don't breathe vapors. If contact with eyes or skin is made, immediately flush with clean water and get medical aid for eyes immediately.

Always place fuel can and stand in well-ventilated area as far away from open flames and other potential ignition sources as possible. Fuel spills must be cleaned up in accordance with local requirements. Combustible material must be kept at least 2 feet away from the sides of the heater during operation.

Always switch heater ON/OFF control to the OFF position and wait until the green HEATER ON/ON-HOLD light is OFF before refueling.

CAUTION

Always keep fuel hoses and fuel cans clean and free of dust, dirt, and water. Make sure fuel hoses lie flat without kinks or loops that could trap air in the lines and slow the fuel flow to the heater.

1. Place ON/OFF switch **(1)** on the in-tent controller assembly **(2)** in the OFF position or verify that it is in the OFF position and wait until the all fans stop and all advisory lights **(3)** have gone off.
2. If the heater assembly was operating, allow the heater assembly to complete the post-purge mode and ensure that all advisory lights on the in-tent controller assembly are off.

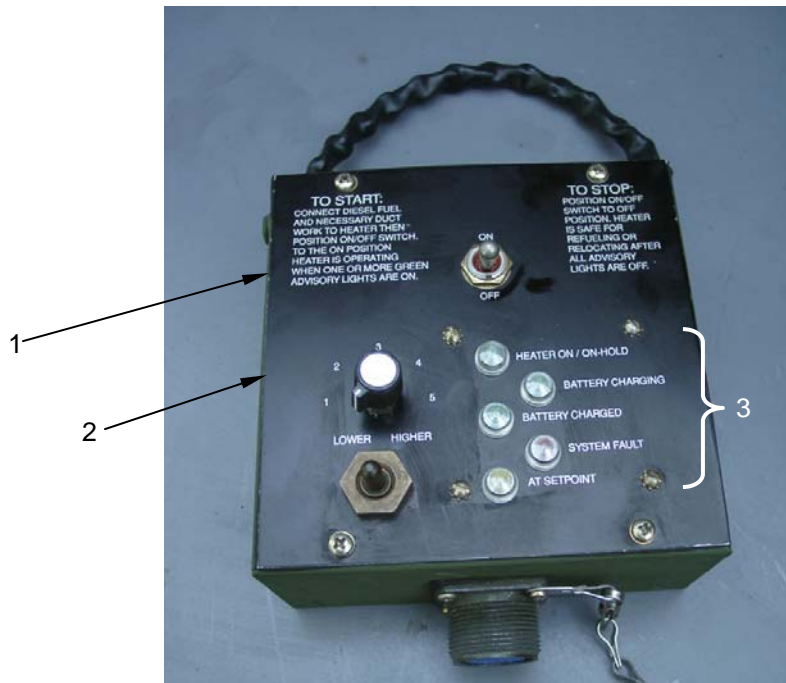

3. When the blower fans stop at the end of the post-purge mode, remove the fuel can **(1)** from the fuel can stand assembly **(2)**. Set the fuel can down in the upright position.
4. Place a petroleum absorbent material tray or mat under the heater fuel connector **(3)** to collect the small amount of fuel that may drain from heater and the fuel hoses.
5. Remove the fuel hose quick disconnect **(4)** from the heater fuel connector **(3)** and lift the hose **(5)** above the level of fuel can **(1)**. This will allow all the fuel to drain back into the fuel can. Place the end of the hose on the petroleum absorbent mat or tray.
6. Remove gravity feed adapter **(6)** from fuel can **(1)**. Make sure all components of the fuel system are clean and free of dirt and damage that could contaminate the fuel supply or cause leakage.
7. Obtain a fuel can full of the newly selected approved fuel. Remove fuel cap and install fuel can adapter **(6)** onto fuel can **(1)**. Tighten securely.
8. Attach fuel hose quick disconnect **(4)** to the heater fuel connector **(3)**.
9. Place fuel can **(1)** onto fuel can stand assembly **(2)** and strap in place in accordance with tag attached to stand assembly or the section of WP 0005 00 entitled "Assemble the Fuel Can Stand."
10. Make sure fuel connections are tight and that there are no fuel leaks.
11. Make sure fuel hose **(5)** lies flat on the ground and is not looped or kinked.

12. Heater assembly is now ready for operation. Make sure heater setup has not been changed, ducts and pipes are properly positioned, and heated air is directed in a safe manner. See applicable setup instructions in this section to confirm correct setup.



13. Place the heater ON/OFF switch **(1)** of the in-tent controller assembly **(2)** in the ON position and verify that green HEATER ON/ON-HOLD light **(3)** is lit. (Refer to troubleshooting if light is not on). At a minimum, allow the heater to run through a complete charging cycle. A charging cycle starts when the heater ON/OFF switch is moved to the ON position and ends when green BATTERY CHARGED light **(4)** comes on.
14. If heat is no longer desired, place the heater ON/OFF switch **(1)** in the OFF position and verify that the blower fans stop after post-purge. Cool down is then complete.



HEATER SHUTDOWN

1. Place the ON/OFF switch (1) on the in-tent controller assembly (2) in the OFF position.
2. Allow the heater assembly to complete the purge cycle.
3. When the blower fans stop and all advisory lights are off, the heater assembly is shut down.



CHARGING THE BATTERY WITH AN EXTERNAL CHARGER**NOTE**

Before charging the battery with an external charger, ensure the heater is shutdown IAW the Heater Shutdown paragraph in this WP.

Under normal conditions, the Space Heater, Convective is responsible for recharging the on-board battery pack. However, there may be some instances where it is required that the battery be recharged using a commercially available 115 VAC to 12 VDC charger. To accomplish this, a battery-charging adapter has been supplied with the heater that permits the connection of a charger to the battery pack.

CAUTION

Do not permit the battery charger terminals to come in contact with the metal casing of the heater. Failure to comply may cause damage to the charger, battery pack assembly, or the electrical components.

NOTE

No grounding is necessary when using the battery-charging adapter.

To charge the battery **(1)** with a commercial 115 VAC to 12 VDC battery charger **(5)** complete the following steps:

1. Disconnect the battery connector **(2)** from the heater and engage the connector on the end of the battery charging adapter **(6)** with the connector on the battery pack.
2. Connect the positive (+) lead of the battery charger **(5)** to the red (+) wire **(3)** of the battery charging adapter and the negative (-) lead of the battery charger **(5)** to the black (-) wire **(4)** of the battery-charging adapter.

CAUTION

Ensure battery charging adapter is set to 12 VDC for charging.

3. Once the battery charger **(5)** is connected to the battery-charging adapter properly, connect battery charging adapter to power source, and turn on the power to the battery charger **(5)**.

NOTE

Depending upon the battery temperature, recharge time for the battery will be approximately 30 minutes. The battery will take longer to recharge in cold weather conditions.

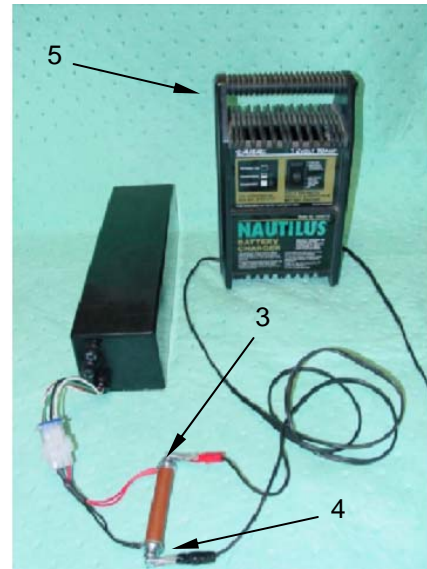
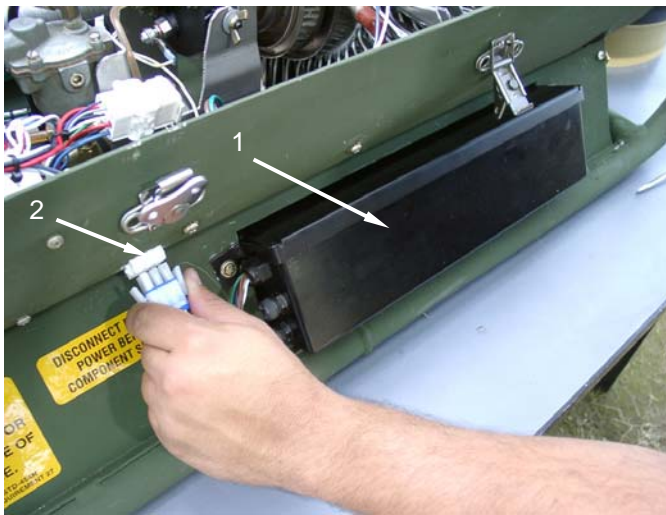

CHARGING THE BATTERY USING A NATO CHARGING SYSTEM

Under normal conditions, the SHC-35K is responsible for recharging the on-board battery pack. If necessary, a NATO charging system cable (1) with integral transformer may be used to charge the battery on the SHC-35K.



NOTE

It may be necessary to remove the battery from the heater in order to use the NATO charging system. If so, notify Unit maintenance.

1. To charge the battery **(2)** using a NATO charging system **(1)**, disconnect the battery connector **(3)** from the heater and engage the connector **(4)** on the end of the NATO charging adapter with the connector on the battery pack.
2. Plug the slave connection **(5)** into the matching receptacle on the vehicle or equipment used to provide electrical power.
3. Verify that the charging unit green power light **(6)** is blinking, indicating that the NATO charging system **(1)** is charging.
4. When the charging unit green power light **(6)** stops blinking and stays lit, this indicates that the battery is charged.

NOTE

Depending upon the battery temperature, recharge time for the battery will be approximately 30 minutes. The battery will take longer to recharge in cold weather conditions.

5. Disconnect the NATO charging system **(1)**, and reconnect the battery connector to the heater.



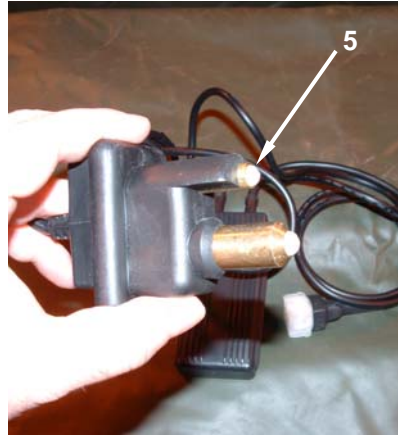
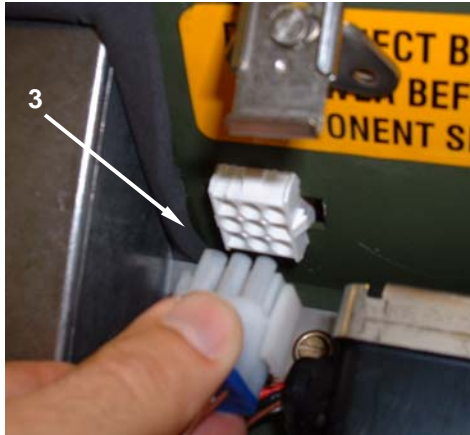

PREPARATION FOR MOVEMENT

To break the system down in preparation for movement, ensure that the heater is off, the blower fans stopped, and all advisory lights off.

1. Remove the fuel can from the fuel can stand assembly. Set the fuel can down in the upright position.
2. Place a mat or tray containing petroleum absorbent material under the heater fuel quick disconnect to collect the small amount of fuel that may drain from heater and the fuel hose.
3. Disconnect the in-tent controller cable from the control connector on the front of the heater and immediately install the protective dust caps on the control connector and the cable connector.
4. Disengage the fuel hose from the fuel quick disconnect and lift the hose above the level of fuel can. This allows all fuel to drain back into the fuel can. Install the protective dust cap on the fuel quick disconnect.
5. Coil the fuel hose back to the fuel supply site and disconnect the fuel hose from the gravity feed adapter. Connect the two ends of the fuel hose together to keep dirt or contaminants from entering the fuel connectors. Place the fuel hose on the petroleum absorbent mat.
6. Place a petroleum absorbent tray under the heater below the fuel drain fitting. Open the drain fitting and allow all the fuel to drain. Close the drain fitting when all the fuel has emptied.
7. Loosen the gravity feed adapter and remove it from the fuel can. Place the gravity feed adapter on the petroleum absorbent mat and wipe any residual fuel off the gravity feed adapter with the mat prior to storage. Install the cap on the fuel can and tighten securely.
8. Disassemble the fuel can stand by removing the clip, raising the two support arms, and separating the lower legs from the upper portion of the stand. Wrap the straps around the stand and secure.
9. Remove both the air supply and return ducts from the heater by releasing the strap and sliding off the duct adapter.
10. Untie both tent duct tunnel straps and remove both ducts from their respective tent duct tunnels.
11. Remove the in-tent controller and disconnect the in-tent controller cable. Install the protective caps on the connectors of the in-tent controller and cable.
12. Secure both tent duct tunnels by closing off with tie straps.
13. Compress both ducts and stow in accessory bag.
14. Install the dust covers over the inlet and outlet duct adapters.
15. Stow all components except the heater in the accessory bag.
16. Store and transport the heater in the horizontal position. Do not place it on end.
17. If the heater transport bag is available, store the heater inside the bag for movement.



Drain Fitting Closed



Drain Fitting Open

**SPACE HEATER, CONVECTIVE (SHC)
OPERATION UNDER UNUSUAL CONDITIONS**

OPERATION IN EXTREME SAND, DUST, AND/OR HIGH WINDS



WARNING

The heater has been designed to operate in dusty or sandy conditions. However, some forms of very fine dusts may be explosive (e.g., flour, chaff, coal, etc.). Before operation of the heater in dusty conditions, an attempt should be made to identify the dust type to insure that it is not explosive in nature.

If possible, the heater should be positioned to minimize the amount of dust, sand, or any other material in the area that could be pulled into the heater by the fans (air flow is 250 cubic feet per minute (CFM) during normal operation of the heater).

When operating in conditions of extreme sand or dust, it is recommended that the air supply **(1)** and return ducts **(2)** be secured to the heater and the ducts securely connected to the tent.

When high winds are expected, the fuel can stand **(3)**, ducts **(1)**, **(2)**, and the heater itself **(4)** may require additional anchor or tiedowns to prevent high winds from shifting the equipment.

During refueling and at regular intervals between refueling, the heater **(4)**, and its ducts **(1)**, **(2)** should be inspected for a buildup of dust or sand that would cover the heater or block the ducts or pipes.

During refueling and at regular intervals between refueling, the sediment strainer **(5)** should be visually checked for dirt or other contamination. If dirt or other contamination is present, the sediment strainer should be serviced in accordance with WP 0020 00 entitled "Solenoid Valve and Sediment Strainer Assembly."

Special care should be used during refueling to prevent sand or dust contamination of fuel, fuel can, and fuel hoses.

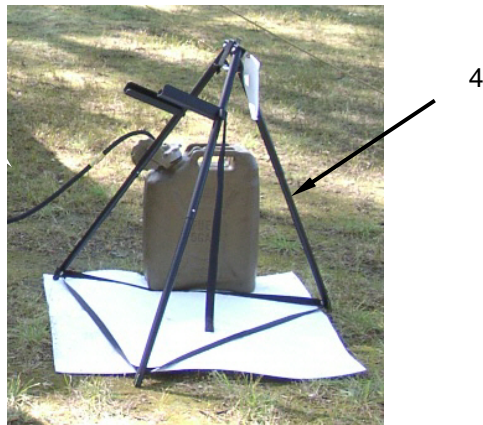
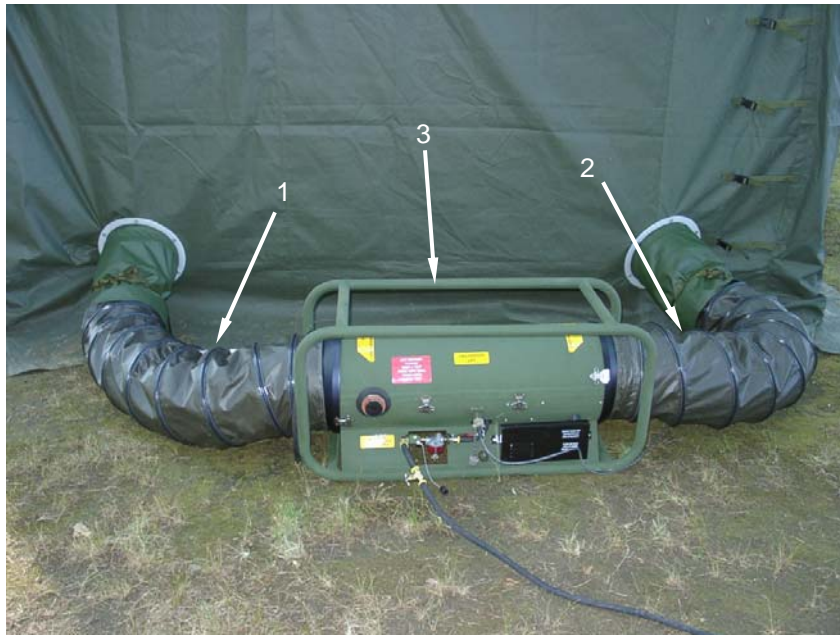

OPERATION IN EXTREME RAIN OR HUMIDITY

When operating in conditions of extreme rain or humidity, it is recommended that the heated air outlet duct **(1)** with debris grill and air supply inlet duct **(2)** with debris grill be secured to the heater and the ducts securely connected to the tent.

Under no circumstances should the heater be positioned in standing water. Heater site should be graded slightly, if necessary, to insure that water runs away from heater and tent.

NOTE

Heater will not operate when tilt or grade is greater than 15 degrees, which is a 1.5-ft drop over a 10-ft span.

Ducts **(1)**, **(2)**, and the heater **(3)** itself might need to be raised higher off the ground to prevent water from entering the heater, especially the base of the heater housing. The base contains three sealed compartments in which the battery, combustion blower, and electronic controller are located. These compartments must not be submerged in standing water. If the heater is to be raised above ground level, make sure that water cannot run along ducts or heater control assembly lead and find its way into the tent.

If high winds accompany rain or humidity, additional anchors or tiedowns may be required to prevent winds from shifting the equipment.

If high winds accompany the rain or humidity, the fuel can stand **(4)** should be firmly anchored to the ground. (Tent stakes and line can be used as an improvised anchor and tiedown.)

During refueling and at regular intervals between refueling, the heater **(3)**, its ducts **(1)**, **(2)** should be inspected for a buildup of snow, dust, or sand that would cover the heater or block the ducts or pipes. Any buildup should be removed.

During refueling and at regular intervals between refueling, the sediment strainer **(5)** of the heater should be visually checked for contamination. If dirt or other contamination is present, the sediment strainer should be serviced in accordance with WP 0020 00 entitled "Solenoid Valve and Sediment Strainer Assembly."

Special care should be used during refueling to prevent water, snow, sand, or dust contamination of fuel, fuel can, fuel hose, and fuel fittings.

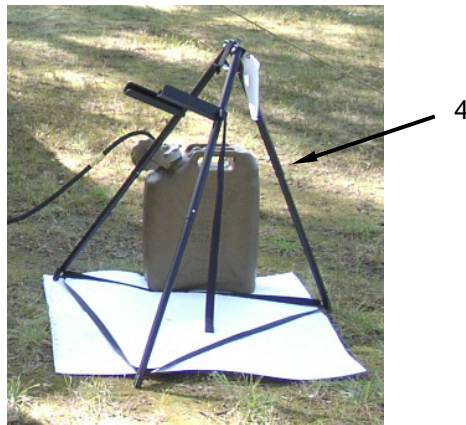
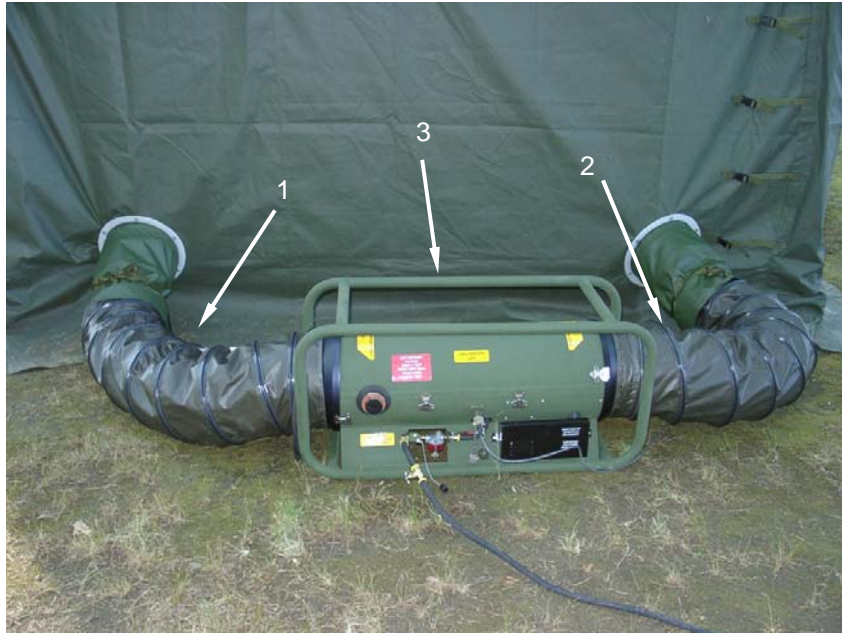

OPERATION IN EXTREME COLD (Temperatures Below -25°F [-31.7°C]).

When operating in conditions of extreme cold, it is recommended that the heated air outlet duct with debris grill **(1)** and air supply inlet duct with debris grill **(2)** be secured to the heater and the ducts securely connected to the tent. Under no circumstances should the heater or the ducts be allowed to be covered with snow.

When operated outside of the tent, ducts **(1)**, **(2)**, and the heater **(3)** itself may require that they be raised higher off the ground to prevent snow from entering the heater.

If high winds accompany extreme cold, additional anchors or tiedowns may be required to prevent winds from shifting the equipment. (Tent stakes and line can be used as an improvised anchor and tiedown.)

If high winds accompany the snow, the fuel can stand **(4)** should be firmly anchored to the ground.

During refueling and at regular intervals between refueling, ducts **(1)**, **(2)**, and the heater **(3)** itself should be inspected for a build up of snow, dust, or sand that would cover the heater or block the ducts or pipes. Any buildup should be removed.

During refueling and at regular intervals between refueling, the sediment strainer **(5)** of the heater should be visually checked for contamination. If dirt or other contamination is present, the sediment strainer should be serviced in accordance with WP 0020 00 entitled "Solenoid Valve and Sediment Strainer Assembly."

Special care should be used during refueling to prevent snow and ice from contaminating fuel, fuel can, fuel lines, and fuel fittings.

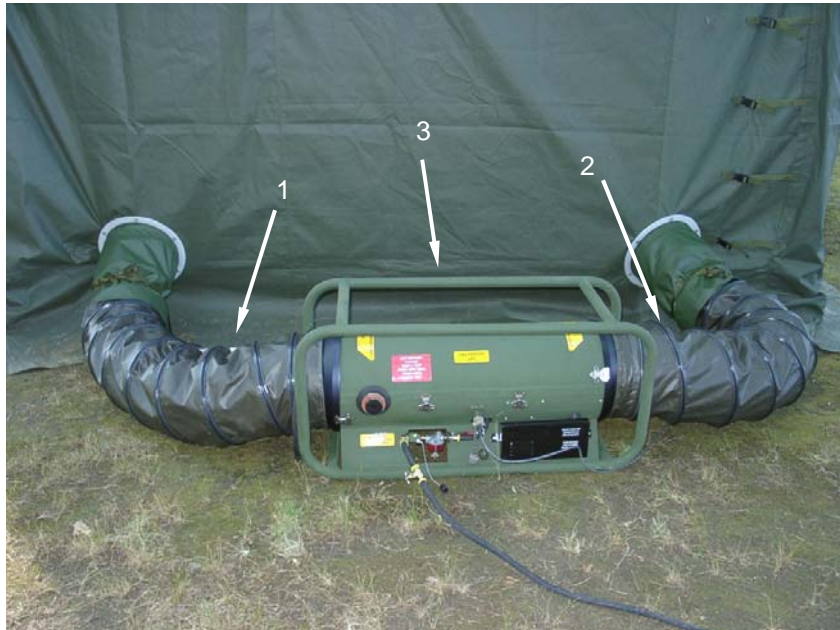

OPERATION IN MODERATE CLIMATES

When used in moderate climates, such as the southern United States, the SHC may overheat the inside of the tent (temperatures in excess of 90° F). The in-tent controller responds with a number 10 fault code (tent over temperature). This causes the heater to shut down as soon as the "Battery Charged" light is illuminated. After the tent cools, the heater cycles back on. The heater continues to cycle on and off until conditions change (e.g. outside air temperature drops). The on-off cycling causes the burner to carbon-up leading to premature failure of the glow plug. If the heater has been cycling excessively and glow plug failure is experienced, the burner must be cleaned IAW WP 0037 00.

To alleviate the cycling problem, open the door and cool the interior of the tent IAW WP 0009 00. If the problem persists, remove the heater inlet duct (1) from the tent wall (2). The inlet duct (1) needs to remain attached to the heater to keep rain and snow from entering the body of the heater. The heater should be operated in this configuration until the air temperature decreases or the tent cannot be adequately heated. The return air duct may then be reinstalled in the tent wall.



TM 10-4520-262-12&P

CHAPTER 3
TROUBLESHOOTING PROCEDURES
SPACE HEATER, CONVECTIVE

**SPACE HEATER, CONVECTIVE (SHC)
TROUBLESHOOTING MALFUNCTION SYMPTOM INDEX**

TROUBLESHOOTING PROCEDURES

Tables 1 and 2 lists common malfunctions that you may encounter with your equipment along with the troubleshooting procedure related to that malfunction. Refer to the list and locate the particular problem you are experiencing. Once you have found the problem in the list, go to the specific troubleshooting procedure detailed in WP 0009 00 or in WP 0009 01 related to that problem. Perform the tests, inspections, and corrective actions in the order they appear in the troubleshooting procedure.

The fault codes listed in Table 1 refer to codes displayed visually via the System Fault advisory light and heard audibly through the in-tent controller assembly. For example, if the System Fault advisory light flashes 5 times accompanied by 5 audible tones, this indicates a Fault Code 5 which, by referring to Table 1, indicates a "Glow Plug" problem. You would then refer directly to Item Number 9 in the troubleshooting work package for detailed troubleshooting procedures on that subject.

This table cannot list all the malfunctions that may occur, all the tests and inspections needed to find the fault, or all the corrective actions needed to correct the fault. If the equipment malfunction is not listed or actions listed do not correct the fault, notify your supervisor and they will notify unit maintenance.

MALFUNCTION SYMPTOM INDEX

Table 1. Operator Malfunction Symptom Index.

Malfunction	Troubleshooting Procedure
Heater Fails to start	1
Smokes continuously	2
Battery charging light does not come on	3
Battery charged light does not come on	4
Fault code 1 - Low voltage	5
Fault code 2 - Combustion blower	6
Fault code 3 - Loss of flame	7
Fault code 4 – Burner Maintenance	8
Fault code 5 - Glow plug	9
Fault code 6 - TEG over temperature	10
Fault code 7 - Over voltage	11
Fault code 8 - Tip-over	12
Fault code 9 - Fin temp sensor	13
Fault code 10 - Tent over temperature	14
Fault code 12 – Low System Voltage	15

Table 2. Unit Malfunction Symptom Index.

Malfunction	Troubleshooting Procedure
Heater Fails to start	1
Heater emits black smoke continuously during operation.	2
Battery Charging Light does not Come on	3
Battery Charged Light does not Come on	4
Fault code 1 – Battery Low voltage	5
Fault code 2 - Locked Rotor, Combustion Blower Assembly (motor does not run)	6
Fault code 3 - Flame Loss	7
Fault code 4 – Burner Maintenance Required	8
Fault code 5 - Glow plug	9
Fault code 6 - TEG Over Temperature	10
Fault code 7 - Over voltage	11
Fault code 8 - Tip-over	12
Fault code 9 - Fin Temperature Sensor	13
Fault code 10 - Tent OverTemperature	14
Fault code 12 – Low System Voltage	15

OPERATOR MAINTENANCE**SPACE HEATER, CONVECTIVE****(NSN 4520-01-431-8927)**

TROUBLESHOOTING PROCEDURES

INITIAL SETUP**Tools**

Wrench (Table 2, Item 2, WP 0044 00)

Materials/Parts

Rags, Wiping, Clean (Item 5, WP 0067 00)

Equipment ConditionHeater shut down, all advisory lights off, fans stopped before attempting corrective action(s) (WP 0006 00)

GENERAL**CAUTION**

When encountering a problem with the Space Heater, Convective, be sure to turn the ON/OFF switch on the in-tent controller to the OFF position, wait for all advisory lights to go off, and all fans to stop before performing the corrective actions detailed in the table that follows. Once the corrective action has been taken, attempt a restart of the heater and verify that the problem no longer exists. Failure to shut the heater off before taking some corrective actions may damage the heater.

The troubleshooting table that follows lists common malfunctions that you may encounter with your equipment. Perform the tests, inspections, and corrective actions in the order they appear in the table. Refer to the malfunction symptom index for a listing of all the problems that may be encountered and proceed to the troubleshooting procedure indicated in the index.

This table cannot list all the malfunctions that may occur, all the tests and inspections needed to find the fault, or all the corrective actions needed to correct the fault. If the equipment malfunction is not listed or actions listed do not correct the fault, notify your supervisor and they will refer the equipment to unit maintenance.

Table 1. Operator Troubleshooting Procedures.

MALFUNCTION	TEST OR INSPECTION	CORRECTIVE ACTION
<p>1. Heater Fails to Start.</p>	<p>Step 1. Check fuel supply level.</p> <p>Step 2. Has the manual reset thermostat been tripped?</p> <p>Step 3. Check sediment strainer assembly and make sure that sediment strainer is free of water, ice, dirt, or other foreign material.</p> <p>Step 4. Has the green ON/ON-HOLD light been lit for more than 3 minutes but the heater has still not started?</p> <p>Step 5. Does the ON/ON-HOLD advisory light come on momentarily, but shut down followed by the system fault light flashing?</p> <p>Step 6. Check that the in-tent controller cable is securely connected to the in-tent controller and to the control connector at the lower housing.</p> <p>Step 7. Remove fuses from battery pack. Visually inspect the element inside the fuse to ensure both fuses are in good condition.</p> <p>Step 8. Is the battery pack connector securely engaged in the connector on the lower housing?</p>	<p>Fill fuel can if necessary.</p> <p>Remove any obstructions from heater inlet and outlet to allow free air movement. Reset the manual reset thermostat.</p> <p>Refer to WP 0010 00, Before PMCS, Sediment Strainer Assembly.</p> <p>System could be in post purge mode. Allow up to 10 minutes before placing the ON/OFF switch in the OFF position. Try starting again.</p> <p>Count the number of times the System Fault light flashes as well as the number of audible tones heard. Record the number of times the system fault advisory light flashes and refer to the troubleshooting instructions later in this section for that specific fault code.</p> <p>Securely connect the in-tent controller cable to the control connector located on the lower housing.</p> <p>If the fuse(s) is/are bad or if in doubt, replace bad fuse(s) with spare fuse(s) located behind duct adapter at heater inlet assembly.</p> <p>Make sure that the battery pack connector is securely engaged in the connector on the lower housing. Make sure the connector locks in place.</p>

Table 1. Operator Troubleshooting Procedures - Continued.

MALFUNCTION	TEST OR INSPECTION	CORRECTIVE ACTION
1. Heater Fails to Start - Continued	<p>Step 9. Does the burner assembly have carbon build-up and require cleaning?</p> <p>Step 10. Has burner reached its maximum life and require replacement?</p>	<p>If yes, notify unit maintenance.</p> <p>If yes, notify unit maintenance.</p>
2. Heater emits black smoke continuously during operation	<p>Step 1. Check to make sure that vent openings on the front of the combustion air inlet cover are clear of snow or other obstructions.</p> <p>Step 2. Check to make sure the combustion exhaust pipe is clear of snow or other obstructions.</p> <p>Step 3. Check that the correct fuel being used for the outside temperature where the heater is being operated.</p> <p>Step 4. Verify that there is no water or other contaminants in the fuel supply.</p> <p>Step 5. Check to make sure the tent wall does not obstruct the heater ducts.</p> <p>Step 6. If heater is running on diesel fuel, change fuel to JP-8.</p> <p>Step 7. Does the burner assembly have carbon build-up and require cleaning?</p> <p>Step 8. Has the burner reached its maximum life and require replacement?</p>	<p>Clear combustion inlet area of snow or any other obstructions.</p> <p>Clear combustion exhaust pipe area of snow or other obstructions.</p> <p>Refer to WP 0001 00, Table 3. Approved Fuels At Various Temperatures. Use the appropriate fuel for the temperature in which the heater is operating.</p> <p>Replace contaminated fuel with new can of clean, uncontaminated fuel.</p> <p>Install a Tent Wall Modification Kit. Refer to instructions in WP 0005 00.</p> <p>If fuel cannot be changed to JP-8, then the burner may require cleaning every 250 hours of running time. Notify unit maintenance.</p> <p>If yes, notify unit maintenance.</p> <p>If yes, notify unit maintenance.</p>



Table 1. Operator Troubleshooting Procedures - Continued.

MALFUNCTION	TEST OR INSPECTION	CORRECTIVE ACTION
<p>3. Battery Charging Light does not come on</p>	<p>Step 1. Remove fuses from battery pack. Visually inspect the element inside the fuse to ensure both fuses are in good condition.</p> <p>Step 2. Check to make sure that the battery connector is fully inserted.</p> <p>Step 3. Verify that the vent openings on combustion air inlet cover or the combustion exhaust pipe are clear of snow and other obstructions.</p> <p>Step 4. Check fuel supply. Is fuel can full of proper fuel for temperature conditions?</p> <p>Step 5. Is there a kink or loop in the fuel hose restricting the flow of fuel to the heater?</p> <p>Step 6. Look through the sediment strainer glass bowl and make sure that sediment strainer is free of water, ice, dirt, or other foreign material.</p> <p>Step 7. Remove upper housing assembly and verify that the leads going to the thermoelectric generator assembly are securely attached to the modular connector.</p>	<p>If one or more fuse is bad or if in doubt, replace bad fuse(s) with spare fuse(s) located behind duct adapter at heater inlet assembly.</p> <p>Push the battery pack assembly connector firmly into the connector on the lower housing assembly. Ensure that the locking clips on the connector have fully engaged.</p> <p>Clear inlet and exhaust areas of any obstructions.</p> <p>Refer to WP 0001 00, Table 3. Approved Fuels At Various Temperatures. Change the fuel to coincide with the appropriate temperature conditions.</p> <p>Remove any kinks or loops in the fuel hose and make sure that it lies flat along ground.</p> <p>Ensure that there are no kinks in the hose on the gravity feed adapter.</p> <p>Ensure that all fuel quick disconnect connectors are securely attached.</p> <p>Clean sediment bowl. Refer to WP 0010 00, Before PMCS, Sediment Strainer Assembly.</p> <p>Ensure that TEG leads are installed in modular connector and that connector screws are secure.</p>

Table 1. Operator Troubleshooting Procedures - Continued.

MALFUNCTION	TEST OR INSPECTION	CORRECTIVE ACTION
3. Battery Charging Light does not come on – Continued	Step 8. Check the burner assembly for carbon build-up.	If there is carbon build-up, notify unit maintenance.
4. Battery Charged Light does not come on	<p>Step 1. Is the heater operating in extremely cold conditions? Did the battery pack possibly have a low charge before operation?</p> <p>Step 2. Has there been more than one startup attempt in cold weather?</p> <p>Step 3. Is fuel can full of proper fuel type for temperature conditions?</p> <p>Step 4. Is there a kink or loop in the fuel hose restricting the flow of fuel to the heater?</p> <p>Step 5. Check the burner assembly for carbon build-up.</p> <p>Step 6. Check the fuel pump.</p>	<p>Wait for a longer period of time for the battery to charge. Battery should be fully charged within 60 minutes of heater operation.</p> <p>If there has been more than one startup attempt in cold weather, the battery may be severely depleted and may require up to 2 hours to recharge.</p> <p>Refer to WP 0001 00, Table 3. Approved Fuels At Various Temperatures. Verify that fuel being used is appropriate for the temperature in which the heater is operating.</p> <p>Remove any kinks or loops in the fuel hose and make sure that it lies flat along ground.</p> <p>Ensure that there are no kinks in the hose on the gravity feed adapter.</p> <p>Ensure that all fuel quick disconnect connectors are securely engaged.</p> <p>If there is carbon build-up, notify unit maintenance.</p> <p>Notify unit maintenance.</p>



Table 1. Operator Troubleshooting Procedures - Continued.

MALFUNCTION	TEST OR INSPECTION	CORRECTIVE ACTION
4. Battery Charged Light Does Not Come On - Continued	Step 7. Check the thermoelectric generator.	Notify unit maintenance.
5. Fault Code 1 – Battery Low Voltage	<p>Step 1. This fault condition is caused by the battery having less than the required voltage to start or operate the heater.</p> <p>Step 2. Is the battery fully charged?</p>	<p>Remove fuses from battery pack. Visually inspect the element inside the fuse to ensure both fuses are in good condition.</p> <p>If one or more fuse is bad or if you are in doubt, replace bad fuse(s) with spare fuse(s) located behind duct adapter at heater inlet assembly.</p> <p>If condition persists, notify unit maintenance.</p> <p>Charge the battery using battery charging adapter IAW WP 0006 00.</p>
6. Fault Code 2 – Locked Rotor, Combustion Blower Assembly (motor does not run)	<p>A locked fan rotor within the combustion air blower assembly causes this fault condition. It is possible for snow or ice to be ingested in the fan. The snow or ice melts and then refreezes, locking the rotor.</p> <p>Step 1. Is the fan rotor on the combustion air blower assembly locked by ice or snow?</p>	<p>If rotor is not locked due to snow or ice ingestion, notify unit maintenance and schedule the replacement of the combustion air blower assembly.</p>
7. Fault Code 3 – Flame Loss	Step 1. Was the heater running and then quit?	<p>Fill the fuel can with the proper fuel type for the temperature conditions. Refer to WP 0001 00, Table 3. Approved Fuels at Various Temperatures. Verify that fuel being used is appropriate for the temperature in which the heater is operating.</p> <p>Check the umbrella valve on the gravity feed adapter to see if is sticking and not allowing air into the fuel can. Refer to WP 0010 00.</p>

Table 1. Operator Troubleshooting Procedures - Continued.

MALFUNCTION	TEST OR INSPECTION	CORRECTIVE ACTION
<p>7. Fault Code 3 – Flame Loss - Continued</p>	<p>Step 2. Has the manual reset thermostat been tripped?</p> <p>Step 3. Is there a kink or loop in the fuel hose restricting the flow of fuel to the heater?</p> <p>Step 4. Look through the sediment strainer glass bowl and make sure that sediment strainer is free of water, ice, dirt, or other foreign material.</p> <p>Step 5. Are combustion air inlet cover vents and exhaust pipe clear of obstructions?</p> <p>Step 6. Verify the heater has started and shut down after approximately 30 seconds. Verify that the heater has generated a fault code 3.</p> <p>Step 7. Does the burner assembly have carbon build-up and require cleaning?</p> <p>Step 8. Has the burner reached its maximum life and require replacement?</p>	<p>Remove any obstructions from heater inlet and outlet to allow free air movement. Reset manual reset thermostat.</p> <p>Remove any kinks or loops in the fuel hose and make sure that it lies flat along ground.</p> <p>Ensure that there are no kinks in the hose on the gravity feed adapter.</p> <p>Ensure that all fuel quick disconnect connectors are securely engaged.</p> <p>Refer to WP 0010 00, Before PMCS, Sediment Strainer Assembly.</p> <p>Clear combustion air inlet and exhaust pipe areas.</p> <p>Remove the flame sensor IAW WP 0012 00 and ensure that it is not iced over or covered with soot that would obscure the sensor. Re-install the flame sensor and attempt a restart.</p> <p>If the heater still fails to operate, replace flame sensor as detailed in WP 0012 00.</p> <p>If yes, notify unit maintenance.</p> <p>If yes, notify unit maintenance.</p>



Table 1. Operator Troubleshooting Procedures - Continued.

MALFUNCTION	TEST OR INSPECTION	CORRECTIVE ACTION
<p>8. Fault Code 4 – Burner maintenance required</p>	<p>Step 1. Is fuel can full of proper fuel type for temperature conditions?</p> <p>Step 2. Is fuel can full?</p> <p>Step 3. Is there a kink or loop in the fuel hose restricting the flow of fuel to the heater?</p> <p>Step 4. Is the combustion air inlet and combustion exhaust pipe clear of snow and other obstructions?</p> <p>Step 5. Check to make sure the tent wall does not obstruct the heater ducts.</p> <p>Step 6. If heater is running on diesel fuel?</p> <p>Step 7. Check the flame sensor.</p> <p>Step 8. Does the burner assembly have carbon build-up and require cleaning?</p> <p>Step 9. Has the burner reached its maximum life and require replacement?</p>	<p>Refer to WP 0001 00, Table 3. Approved Fuels At Various Temperatures. Use the appropriate fuel for the temperature in which the heater is operating.</p> <p>Fill fuel can.</p> <p>Remove any kinks or loops in the fuel hose and make sure that it lies flat along ground.</p> <p>Ensure that there are no kinks in the hose on the gravity feed adapter.</p> <p>Ensure that all fuel quick disconnect connectors are securely engaged.</p> <p>Clear combustion air inlet vent openings and exhaust pipe areas of any obstructions.</p> <p>Install a Tent Wall Modification Kit. Refer to instructions in WP 0005 00.</p> <p>Change the fuel to JP-8. If the fuel cannot be changed to JP-8, then the burner may require cleaning. Notify unit maintenance.</p> <p>Remove the flame sensor IAW WP 0012 00 and ensure that it is not iced over or covered with soot that would obscure the sensor. Re-install the flame sensor and attempt a restart.</p> <p>If yes, notify unit maintenance.</p> <p>If yes, notify unit maintenance.</p>

Table 1. Operator Troubleshooting Procedures - Continued.

MALFUNCTION	TEST OR INSPECTION	CORRECTIVE ACTION
<p>9. Fault Code 5 – Glow Plug</p>	<p>Step 1. Remove the upper housing assembly and verify that the wire leading to the glow plug is securely attached and not damaged in any way.</p> <p>Step 2. Check the glow plug wire for breaks, cuts, abrasions, or nicks that may cause an open or short.</p>	<p>Make sure that glow plug connector is securely attached to glow plug.</p> <p>If heater still does not operate or fault code persists, replace glow plug as detailed in WP 0013 00.</p> <p>If heater still does not operate after replacing the glow plug or if the fault code persists, notify unit maintenance.</p>
<p>10. Fault Code 6 – TEG Over Temperature</p>	<p>Step 1. Has the TEG overheated?</p> <p>Step 2. Check the TEG sensor for obstructions.</p>	<p>This fault is caused by the TEG overheating. Remove the upper housing assembly and inspect the fins on the TEG to ensure that there is no lint, grass, or other debris that would prevent air from flowing freely through the fins.</p> <p>Check to see if there are any obstructions at the heated air outlet duct and/or the heated air inlet duct restricting free air movement.</p> <p>Remove any obstructions at the heated air outlet or inlet duct.</p> <p>If problem persists, notify unit maintenance.</p> <p>Remove any obstructions at the heated air outlet or inlet duct.</p> <p>Notify unit maintenance.</p>
<p>11. Fault Code 7 – Over Voltage</p>	<p>There is no test or inspection to be performed. This fault is caused by the battery being charged to a higher than rated voltage.</p>	<p>Notify unit maintenance and schedule power control assembly replacement.</p>

Table 1. Operator Troubleshooting Procedures - Continued.

MALFUNCTION	TEST OR INSPECTION	CORRECTIVE ACTION
12. Fault Code 8 – Tip Over	<p>The heater being tipped more than 15 degrees in any direction causes this fault code.</p> <p>Is the heater tipped in excess of 15 degrees?</p>	<p>Check to see if the heater is located on an incline that slopes more than 1.5 feet in a 10-foot span. Move the heater to an area that slopes less than 1.5 feet in a 10-foot span.</p> <p>Check to make sure that any snow under the heater is packed down well. Melting snow under the heater can cause the heater to tip.</p>
13. Fault Code 9 – Fin Temperature Sensor	Is the temperature sensor on the TEG opened or shorted?	Remove the upper housing assembly and verify that the sensor connection is secure. If the sensor connection is secure and fault code 9 persists, notify unit maintenance.
14. Fault Code 10 – Tent Over Temperature.	Is the temperature in the interior of the tent greater than 90 degrees F?	<p>This fault is caused by the tent temperature climbing over 90 degrees F (32.2 degrees C). Open the door and cool the interior of the tent.</p> <p>If problem persists after cooling down interior of the tent, disconnect the air supply inlet duct from the tent duct tunnel and allow the heater to draw cooler outside air.</p> <p>If problem persists, replace control box with a known good control box.</p>

Table 1. Operator Troubleshooting Procedures - Continued.

MALFUNCTION	TEST OR INSPECTION	CORRECTIVE ACTION
15. Fault Code 12 – Low System Voltage	Has the battery been discharged?	<p>This fault is activated when the battery voltage is very low. If the battery has less than 10 volts when the heater is switched on, the voltage at the microprocessor drops below what is required to process information.</p> <p>An excessive number of start attempts, without a recharge cycle, may drain the battery.</p> <p>Fully charge the battery using the battery-charging adapter IAW WP 0006 00.</p> <p>If problem persists, notify unit maintenance.</p>

END OF WORK PACKAGE



UNIT MAINTENANCE
SPACE HEATER, CONVECTIVE
(NSN 4520-01-431-8927)

TROUBLESHOOTING PROCEDURES

Table 1. Unit Troubleshooting Procedures.

MALFUNCTION	TEST OR INSPECTION	CORRECTIVE ACTION
<p>1. Heater Fails to Start.</p>	<p>Step 1. Check the fuel supply.</p> <p>Step 2. Has the manual reset thermostat been tripped?</p> <p>Step 3. Check the sediment strainer assembly and make sure that it is free of water, ice, dirt, or other foreign material.</p> <p>Step 4. Has the green ON/ON-HOLD light been lit for more than 3 minutes but the heater has not started?</p> <p>Step 5. Does the ON/ON-HOLD advisory light come on momentarily, and then shut down followed by the system fault light flashing?</p> <p>Step 6. Check to make sure that the in-tent controller cable is securely connected to the in-tent controller and to the control connector at the lower housing.</p> <p>Step 7. Remove fuses from battery pack. Visually inspect the element inside the fuse to ensure both fuses are in good condition.</p>	<p>Heater may be out of fuel. Fill the fuel can.</p> <p>Remove any obstructions from the heater inlet and outlet to allow free air movement. Reset the manual reset thermostat.</p> <p>Refer to WP 0010 00, Before PMCS, Sediment Strainer Assembly.</p> <p>System could be in post purge mode. Allow up to 10 minutes before placing the ON/OFF switch in the OFF position.</p> <p>Count the number of times the system fault light flashes as well as the number of audible tones heard. Record the number of times the system fault advisory light flashes and refer to the troubleshooting instructions later in this section for that specific fault code.</p> <p>Connect the in-tent controller cable securely to the control connector located on the lower housing.</p> <p>If not, replace the bad fuse(s) with spare fuse(s) located behind duct adapter at heater inlet assembly.</p>

Table 1. Unit Troubleshooting Procedures - Continued.

MALFUNCTION	TEST OR INSPECTION	CORRECTIVE ACTION
<p>1. Heater Fails to Start – Continued.</p>	<p>Step 8. Is the battery pack connector securely engaged in the connector on the lower housing?</p> <p>Step 9. Check the burner assembly for carbon build-up.</p> <p>Step 10. Burner may have reached its maximum life and require replacement.</p>	<p>Securely engage the battery pack connector to the connector on the lower housing. Ensure connector locks in place.</p> <p>Clean the carbon from the burner assembly. Refer to WP 0037 00 for servicing the burner.</p> <p>Refer to WP 0037 00 for burner replacement instructions.</p>
<p>2. Heater emits black smoke continuously during operation.</p>	<p>Step 1. Check to make sure that vent openings on the front of the combustion air inlet cover are clear of snow or other obstructions.</p> <p>Step 2. Check to make sure that combustion exhaust pipe is clear of snow or other obstructions.</p> <p>Step 3. Check that the correct fuel is being used for the outside temperature where the heater is being operated.</p> <p>Step 4. Check to make sure that there is no water or other contaminants in the fuel supply.</p> <p>Step 5. Check to make sure the tent wall does not obstruct the heater ducts.</p> <p>Step 6. If heater is running on diesel fuel, change fuel to JP-8.</p> <p>Step 7. Does the burner assembly require cleaning?</p>	<p>Clear combustion inlet area of snow and other obstructions.</p> <p>Clear combustion exhaust pipe area of snow or any other obstructions.</p> <p>Refer to WP 0001 00, Table 3. Approved Fuels At Various Temperatures. Verify that fuel being used is appropriate for the temperature in which the heater is operating.</p> <p>Replace contaminated fuel with new can of clean, uncontaminated fuel.</p> <p>Install a Tent Wall Modification Kit. Refer to instructions in WP 0005 00.</p> <p>If fuel cannot be changed to JP-8, then the burner may require cleaning every 250 hours of running time. Refer to WP 0037 00 for the burner cleaning instructions.</p> <p>Refer to WP 0037 00 for the burner cleaning instructions.</p>

Table 1. Unit Troubleshooting Procedures - Continued.

MALFUNCTION	TEST OR INSPECTION	CORRECTIVE ACTION
<p>2. Heater emits black smoke continuously during operation-Continued.</p>	<p>Step 8. Has the burner reached its maximum life and require replacement?</p>	<p>Refer to WP 0037 00 for burner replacement instructions.</p>
<p>3. Battery Charging Light does not Come on.</p>	<p>Step 1. Remove fuses from battery pack. Visually inspect the element inside the fuse to ensure both fuses are in good condition.</p> <p>Step 2. Check to make sure that the battery connector is fully inserted.</p> <p>Step 3. Check to ensure that vent openings on combustion air inlet cover or the combustion exhaust pipe are clear of snow and other obstructions.</p> <p>Step 4. Check fuel supply. Is fuel can full of proper fuel for temperature conditions?</p> <p>Step 5. Is there a kink or loop in the fuel hose restricting the flow of fuel to the heater?</p>	<p>If one or more fuse is bad or if in doubt, replace bad fuse(s) with spare fuse(s) located behind duct adapter at heater inlet assembly.</p> <p>Push the battery pack assembly connector firmly into the connector on the lower housing assembly. Ensure that the locking clips on the connector have fully engaged.</p> <p>Clear inlet and exhaust areas of any obstructions.</p> <p>Refer to WP 0001 00, Table 3. Approved Fuels At Various Temperatures. Verify that fuel being used is appropriate for the temperature in which the heater is operating.</p> <p>Remove any kinks or loops in the fuel hose and make sure that it lies flat along ground.</p> <p>Ensure that there are no kinks in the hose on the gravity feed adapter. Ensure that all fuel quick disconnect connectors are securely attached.</p>

Table 1. Unit Troubleshooting Procedures - Continued.

MALFUNCTION	TEST OR INSPECTION	CORRECTIVE ACTION
<p>3. Battery Charging Light does not come on - Continued.</p>	<p>Step 6. Look through the sediment strainer glass bowl and make sure that sediment strainer is free of water, ice, dirt, or other foreign material.</p> <p>Step 7. Remove upper housing assembly and verify that the leads going to the thermoelectric generator assembly are securely attached to the modular connector.</p> <p>Step 8. Check the burner assembly for carbon build-up.</p> <p>Step 9. Check the fuel pump.</p> <p>Step 10. Check the thermoelectric generator.</p>	<p>Clean sediment bowl. Refer to WP 0010 00, Before PMCS Sediment Strainer Assembly. If the strainer requires replacement, follow the instructions in WP 0020 00.</p> <p>Ensure that TEG leads are installed in modular connector and that connector screws are secure.</p> <p>Refer to WP 0037 00 to service the burner.</p> <p>Refer to WP 0034 00 to test or replace the fuel pump.</p> <p>Refer to WP 0038 00 for instructions on testing the TEG.</p>
<p>4. Battery Charged Light does not come on.</p>	<p>Step 1. Is the heater operating in extremely cold conditions? Did the battery pack possibly have a low charge before operation?</p> <p>Step 2. Has there been more than one startup attempt in cold weather?</p> <p>Step 3. Is the fuel can fuel of the proper fuel type for temperature conditions?</p>	<p>Wait for a longer period of time for the battery to charge. Battery should be fully charged within 60 minutes of heater operation.</p> <p>If there has been more than one startup attempt in cold weather, the battery may be severely depleted and may require up to 2 hours to recharge.</p> <p>Refer to WP 0001 00, Table 3. Approved Fuels At Various Temperatures. Use the appropriate fuel for the temperature in which the heater is operating.</p>

Table 1. Unit Troubleshooting Procedures - Continued.

MALFUNCTION	TEST OR INSPECTION	CORRECTIVE ACTION
<p>4. Battery Charged Light does not come On - Continued</p>	<p>Step 4. Is there a kink or loop in the fuel hose restricting the flow of fuel to the heater?</p> <p>Step 5. Does the burner assembly have carbon build-up and require cleaning?</p> <p>Step 6. Check the fuel pump.</p> <p>Step 7. Check the thermoelectric generator.</p>	<p>Remove any kinks or loops in the fuel hose and make sure that it lies flat along ground.</p> <p>Ensure that there are no kinks in the hose on the gravity feed adapter.</p> <p>Ensure that all fuel quick disconnect connectors are securely engaged.</p> <p>Refer to WP 0037 00 to service the burner.</p> <p>Refer to WP 0034 00 to test or replace the fuel pump.</p> <p>Refer to WP 0038 00 for instructions on testing the TEG.</p>
<p>5. Fault Code 1 – Battery Low Voltage</p>	<p>Step 1. This fault condition is caused by the battery having less than the required voltage to start or operate the heater.</p> <p>Step 2. Is the battery fully charged?</p> <p>Step 3. If condition persists, test the battery.</p>	<p>Remove fuses from battery pack. Visually inspect the element inside the fuse to ensure both fuses are in good condition. If one or more fuse is bad or if you are in doubt, replace bad fuse(s) with spare fuse(s) located behind duct adapter at heater inlet assembly.</p> <p>Charge the battery using battery-charging adapter IAW WP 0018 00.</p> <p>Test the battery. Refer to WP 0018 00.</p>

Table 1. Unit Troubleshooting Procedures - Continued.

MALFUNCTION	TEST OR INSPECTION	CORRECTIVE ACTION
<p>7. Fault Code 3 – Flame Loss - Continued</p>	<p>Step 4. Check sediment strainer assembly and make sure that sediment strainer is free of water, ice, dirt, or other foreign material.</p> <p>Step 5. Are combustion air inlet cover vents and exhaust pipe clear of obstructions?</p> <p>Step 6. Verify the heater has started and shut down after approximately 30 seconds. Verify that the heater has generated a fault code 3.</p> <p>Step 7. Does the burner assembly have carbon build-up and require cleaning?</p> <p>Step 8. Has the burner may have reached its maximum life and require replacement?</p>	<p>Refer to WP 0010 00, Before PMCS, Sediment Strainer Assembly.</p> <p>Clear combustion air inlet and exhaust pipe areas.</p> <p>Remove the flame sensor IAW WP 0012 00 and ensure that it is not iced over or covered with soot that would obscure the sensor. Re-install the flame sensor and attempt a restart.</p> <p>If the heater still fails to operate, replace flame sensor as detailed in WP 0012 00.</p> <p>Clean the carbon from the burner assembly. Refer to WP 0037 00 for the burner cleaning</p> <p>Refer to WP 0037 00 for burner replacement instructions.</p>
<p>8. Fault Code 4 – Burner Maintenance Required</p>	<p>Step 1. Is fuel can full of proper fuel type for temperature conditions?</p> <p>Step 2. Is fuel can full?</p> <p>Step 3. Is there a kink or loop in the fuel hose restricting the flow of fuel to the heater?</p>	<p>Refer to WP 0001 00, Table 3. Approved Fuels At Various Temperatures. Verify that fuel being used is appropriate for the temperature in which the heater is operating.</p> <p>Fill fuel can.</p> <p>Remove any kinks or loops in the fuel hose and make sure that it lies flat along ground.</p> <p>Ensure that there are no kinks in the hose on the gravity feed adapter.</p> <p>Ensure that all fuel quick disconnect connectors are securely engaged.</p>

Table 1. Unit Troubleshooting Procedures - Continued.

MALFUNCTION	TEST OR INSPECTION	CORRECTIVE ACTION
<p>8. Fault Code 4 – Burner maintenance Required – Continued.</p>	<p>Step 4. Is combustion air inlet and combustion exhaust pipe clear of snow and other obstructions?</p> <p>Step 5. Check to make sure the tent wall does not obstruct the heater ducts.</p> <p>Step 6. If heater is running on diesel fuel, change fuel to JP-8.</p> <p>Step 7. Check the flame sensor.</p> <p>Step 8. Burner assembly may have carbon build-up and require cleaning.</p> <p>Step 9. Burner may have reached its maximum life and require replacement.</p>	<p>Clear combustion air inlet vent openings and exhaust pipe areas of any obstructions.</p> <p>Install a Tent Wall Modification Kit. Refer to instructions in WP 0005 00.</p> <p>If fuel cannot be changed to JP-8, then the burner may require cleaning every 250 hours of running time. Refer to WP 0037 00, for the Simplified Burner Cleaning instructions.</p> <p>Remove the flame sensor IAW WP 0012 00 and ensure that it is not iced over or covered with soot that would obscure the sensor. Re-install the flame sensor and attempt a restart.</p> <p>If the heater still fails to operate, replace the flame sensor as detailed in WP 0012 00.</p> <p>Clean the carbon from the burner assembly. Refer to WP 0037 00 for the burner cleaning.</p> <p>Refer to WP 0037 00 for burner replacement instructions.</p>
<p>9. Fault Code 5 – Glow Plug</p>	<p>Step 1. Remove the upper housing assembly and verify that the wire leading to the glow plug is securely attached and not damaged in any way.</p>	<p>Make sure that glow plug connector is securely attached to glow plug.</p> <p>If heater still does not operate or fault code persists, replace glow plug as detailed in WP 0013 00.</p> <p>If heater still does not operate after replacing the glow plug, check the glow plug wire for breaks, cuts, abrasions, or nicks that may cause an open or short.</p>

Table 1. Unit Troubleshooting Procedures - Continued.

MALFUNCTION	TEST OR INSPECTION	CORRECTIVE ACTION
13. Fault Code 9 – Fin Temperature Sensor.	Is the temperature sensor on the TEG opened or shorted?	Remove the upper housing assembly and verify that the sensor connection is secure. If the sensor connection is secure and Fault Code 9 persists, replace TEG sensor per instructions in WP 0038 00.
14. Fault Code 10 – Tent Over Temperature.	Is the temperature in the interior of the tent greater than 90 degrees F?	<p>This fault is caused by the tent temperature climbing over 90 degrees F (32.2 degrees C). Open the door and cool the interior of the tent.</p> <p>If the problem persists after cooling down interior of the tent, disconnect the air supply inlet duct from the tent duct tunnel and allow the heater to draw cooler outside air.</p> <p>If problem still persists, replace control box with a known good control box.</p>
15. Fault Code 12 – Low System Voltage	Has the battery been discharged?	<p>This fault is activated when the battery voltage is very low. If the battery has less than 10 volts when the heater is switched on, the voltage at the microprocessor drops below what is required to process information.</p> <p>An excessive number of start attempts, without a recharge cycle, may drain the battery.</p> <p>Fully charge the battery using the battery charging adapter IAW WP 0006 00.</p> <p>If the battery is fully charged and fault code 12 still displays, then the contacts at the wiring harness/control board connection need to be cleaned.</p>

END OF WORK PACKAGE

TM 10-4520-262-12&P

CHAPTER 4

**OPERATOR
MAINTENANCE INSTRUCTIONS**

SPACE HEATER, CONVECTIVE

OPERATOR MAINTENANCE
SPACE HEATER, CONVECTIVE
(NSN 4520-01-431-8927)

PREVENTIVE MAINTENANCE CHECKS AND SERVICES, INTRODUCTION

INTRODUCTION

Preventive Maintenance Checks and Services (PMCS) are performed to keep the Space Heater, Convective in good operating condition. The checks are used to find, correct, or report problems. Operator personnel are to do the PMCS as shown in the PMCS table. PMCS are done every day a heater is operated, using the PMCS table. Pay attention to WARNING and CAUTION statements. A WARNING means someone could be hurt. A CAUTION means equipment could be damaged.

Before you begin using the Convective Space Heater, do **Before PMCS**.

During use of the Convective Space Heater, do **During PMCS**.

After using the Convective Space Heater, do **After PMCS**.

Once a week, do **Weekly PMCS** if the Space Heater, Convective has been in use.

Do **Monthly PMCS** once a month if the Space Heater, Convective has been in use.

If you find something wrong when performing PMCS, fix it using troubleshooting and/or maintenance procedures.

The right-hand column of the PMCS table lists conditions that make the Space Heater, Convective not fully mission capable. Write up the faults that cannot be repaired on DA Form 2404 for unit maintenance. For further information on how to use this form, see DA PAM 750-8.

If tools that are required to perform PMCS are not listed in procedures, notify your supervisor.

OPERATOR LUBRICATION INSTRUCTIONS

Lubrication instructions are in WP 0068 00 of this TM. All lubrication instructions are mandatory.

INSPECTION

Look for signs of trouble. Senses help here. You can feel, smell, hear, or see many problems that can be eliminated before they get worse. Inspect to see if items are in good condition. Are components correctly installed and secured? Is any damage to the frame or components visible? Correct any faults or notify unit maintenance.

ASSOCIATED COMPONENTS

Perform PMCS on the fuel can in accordance with the publications specified in work package 0043 00.

SPECIAL INSTRUCTIONS

Perform "Weekly," as well as "Before," operations PMCS if:

1. The equipment has not been operated since the last weekly check, or has been stored for more than a week.
2. The equipment is being operated for the first time.
3. The equipment has been in long term storage.

LEAKAGE DEFINITION

NOTE

Equipment operation is allowable with minor leakage (Class I or II). Of course, you must consider the fluid capacity in the item/system being checked/inspected. When operating with Class I, or II leaks, continue to check fluid levels as required in your PMCS. When in doubt, notify your supervisor.

NOTE

Class II leaks should be reported to your supervisor.

Class I. Seepage of fluid (as indicated by wetness or discoloration) not great enough to form drops.

Class II. Leakage of fluid great enough to form drops but not enough to cause drops to drip from item being checked/inspected.

Class III. Leakage of fluid great enough to form drops that falls from the item being checked/inspected.

GENERAL SERVICE PROCEDURES

As you perform your PMCS, keep in mind the following:

Bolts, Nuts, and Screws. Check them all for obvious looseness and missing, bent, or broken condition. You cannot try them all with a tool, of course, but look for chipped paint, bare metal, or rust around bolt heads. If you find a problem, report it to your supervisor.

Welds. Look for loose or chipped paint, rust, or gaps where parts are welded together. If you find a bad weld, report it to your supervisor.

Electrical Wires and Connections. Look for cracked or broken insulation, bare wires, and loose or broken connectors. Tighten loose connections and make sure the wires are in good condition. If you find a bad wire or connector, report it to your supervisor.

Fuel Lines and Fittings. Look for wear, damage, and leaks. Make sure clamps and fittings are tight. Wet spots show leaks, but a stain around a fitting or connector can mean a leak. If a leak comes from a loose fitting, connector, or if something is broken or worn out, report it to your supervisor.

Table 1. Operator Preventive Maintenance Checks and Services.

ITEM NO.	INTERVAL	ITEM TO BE CHECKED/SERVICED	PROCEDURE	EQUIPMENT NOT READY/AVAILABLE IF:
1	Before	Air Supply and Return Ducts	<p>Check the air supply and return ducts (1 and 2) for holes and tears in the fabric. Repair damaged ducts if possible, replace duct if damage cannot be repaired.</p> <p>Check outside surface of duct for any dirt or debris. Clean dirt and debris from exterior of duct with a clean dry rag.</p> <p>Check for and remove any obstructions inside of ducts.</p> <p>Inspect straps (3) on ends of ducts for broken buckles, cuts, abrasions, or other damage that would prevent the ducts from having a tight seal to the duct adapter or debris grill.</p> <p>Inspect the debris grill (4) on the end of both ducts and ensure that the grills are not broken or otherwise damaged.</p>	<p>There are holes, tears, or other damage that cannot be repaired and that would permit air to enter or escape through the side walls of the duct.</p> <p>There are obstructions within the duct that cannot be cleared.</p> <p>Straps on ducts are broken.</p> <p>Debris grill missing or broken.</p>

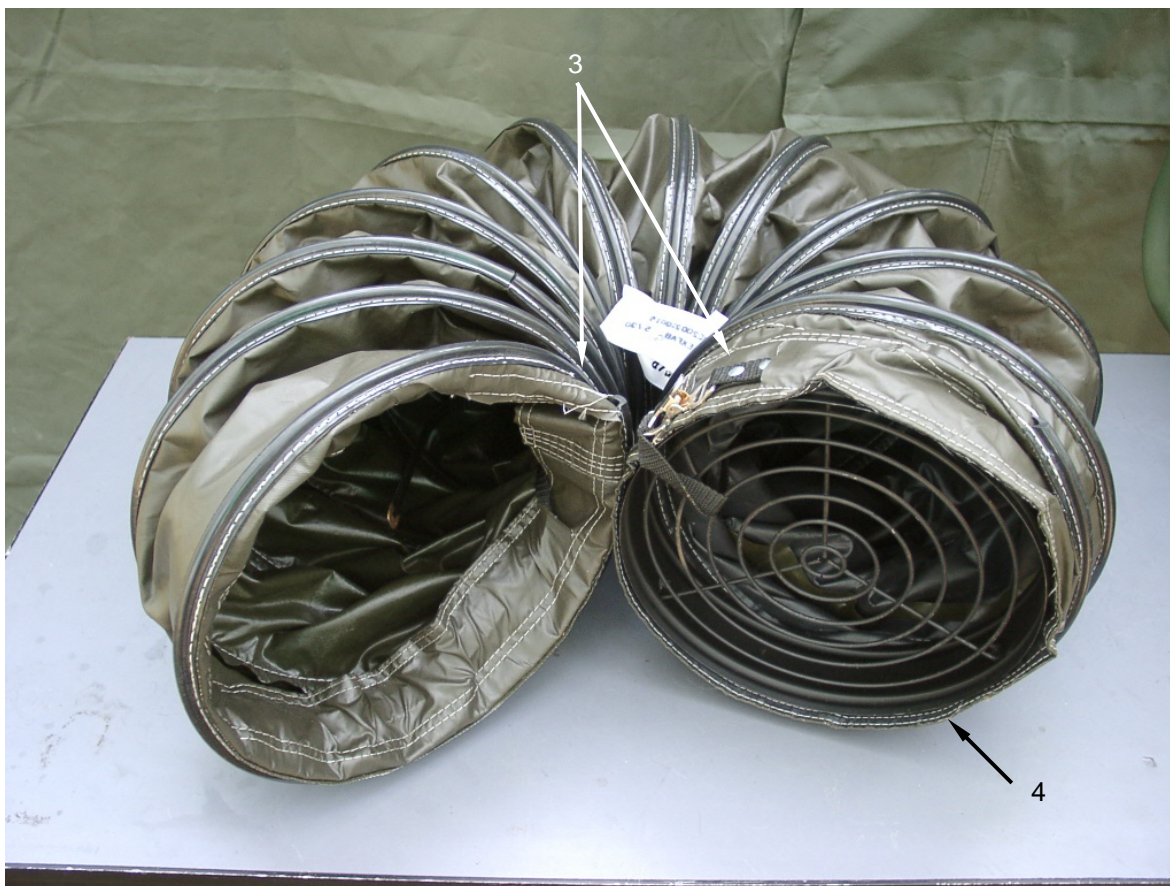

Table 1. Operator Preventive Maintenance Checks and Services. - Continued

ITEM NO.	INTERVAL	ITEM TO BE CHECKED/SERVICED	PROCEDURE	EQUIPMENT NOT READY/AVAILABLE IF:
2	Before	Gravity Feed Adapter	<p>Check Gravity Feed Adapter (1) and fuel hose assembly (2) for leaks.</p> <p>Inspect fitting (3) on Gravity Feed Adapter (1) to ensure that it is not bent, dented, or damaged in any way that would prevent a good, leak proof, seal with the fuel hose (2).</p> <p>Inspect rubber seal (4) on underside of adapter and ensure that it has no cuts, tears or other damage.</p> <p>Remove umbrella valve (5) from valve body (6) by pinching in the center and gently pulling away from valve body. Inspect umbrella valve (5) for nicks or cuts.</p> <p>Inspect valve body (6) of umbrella valve (5) for signs of dirt or foreign matter that may keep the umbrella valve from seating properly or may plug the fuel passages.</p> <p style="text-align: center;">NOTE</p> <p>A spare is located under the cap on top of the GFA.</p>	<p>Gravity Feed Adapter leaks.</p> <p>Quick disconnect fitting is damaged.</p> <p>Seal on underside of adapter is damaged or missing.</p> <p>Replace umbrella valve if nicks or cuts are present. Push gently on center until umbrella valve snaps into place into the valve body.</p> <p>Fuel passages are obstructed by dirt or foreign matter.</p>
3	Before	Fuel Can	<p>Check Fuel Can (7) and ensure that cap (8) seals properly and that there are no cracks in the can that would permit a fuel leak.</p>	<p>Can is damaged and leaking.</p>
4	Before	Fuel Can Stand	<p>Check Fuel Can Stand (9) for bent leg (10), damaged or missing Fuel Can Stand support arms (11). Check for frayed or broken strap (12). Check clip (13) to make sure it is not broken or missing. If Fuel Can Stand is damaged and cannot support the weight of a full fuel can, replace stand.</p>	<p>Stand cannot securely support full fuel can.</p>





5



4

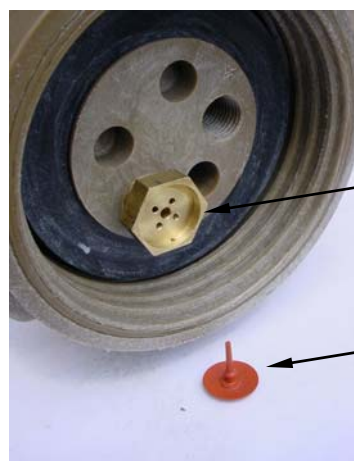

6

5

Table 1. Operator Preventive Maintenance Checks and Services. - Continued

ITEM NO.	INTERVAL	ITEM TO BE CHECKED/SERVICED	PROCEDURE	EQUIPMENT NOT READY/AVAILABLE IF:
5	Before	In-Tent Controller Assembly	<p style="text-align: center;">CAUTION</p> <p>Be sure to perform ONLY a visual check of the ON/OFF switch for damage. DO NOT flip the switch to the ON position.</p> <p>Perform a visual check of the In-Tent Controller Assembly (1) and verify that the ON/OFF switch (2) and LOWER/HIGHER control (3) are undamaged.</p> <p>Check five advisory lights and ensure that none are damaged:</p> <p style="text-align: center;">HEATER ON/ON HOLD (4), BATTERY CHARGING (5), BATTERY CHARGED (6), SYSTEM FAULT (7), and AT SETPOINT (8).</p> <p>Verify that the ON/OFF switch (2) is in OFF position, and the LOWER/HIGHER control (3) is set at LOWER.</p> <p>Ensure that connector (9) and its threads are clean and undamaged, and protective cap (10) is firmly attached by the chain assembly (11).</p>	<p>ON/OFF switch is damaged. LOWER/HIGHER control is damaged.</p> <p>Advisory lights are broken.</p> <p>Connector is dented or has stripped threads.</p>
6	Before	In-Tent Controller Assembly Cable	<p>Check In-Tent Controller Assembly Cable (12) and verify that insulation (13) and connectors (14) are clean and undamaged.</p>	<p>In-Tent Controller Assembly Cable insulation is cut or otherwise damaged exposing wires.</p> <p>Connectors are dented, bent, or otherwise damaged, preventing a secure connection to the In-Tent Controller or heater.</p>

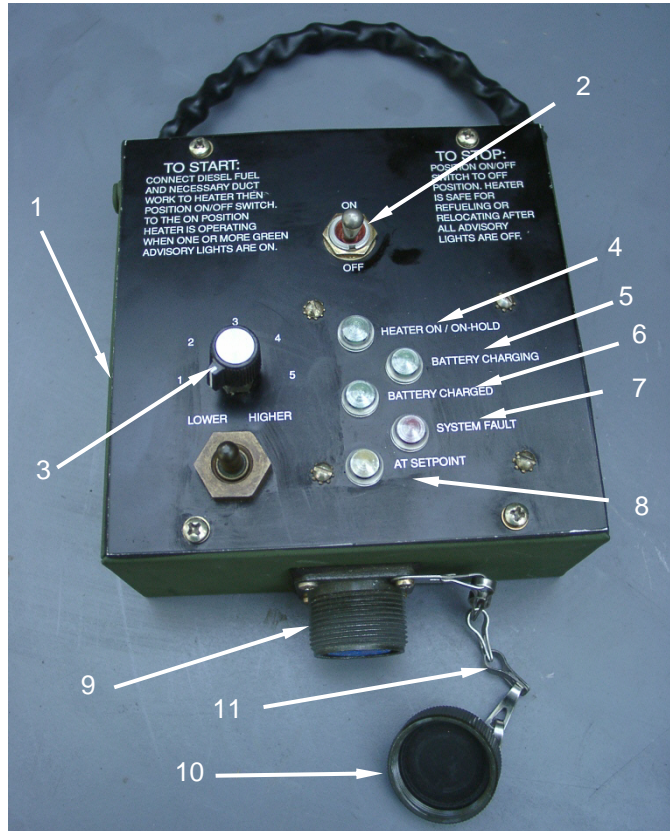

Table 1. Operator Preventive Maintenance Checks and Services. - Continued

ITEM NO.	INTERVAL	ITEM TO BE CHECKED/SERVICED	PROCEDURE	EQUIPMENT NOT READY/AVAILABLE IF:
7	Before	Control Connector (Lower Housing)	<p>Check Control Connector (1) and ensure that it is not dented, bent, or otherwise damaged so as to prevent the In-Tent Controller Cable from making a secure connection.</p> <p>Ensure that the connector (1) does not contain dirt. Verify that the connector does not have stripped threads.</p>	<p>Connector is damaged. Connector has stripped threads.</p> <p>Connector is dirty.</p>
8	Before	Battery Pack	<p>Verify that the Battery Pack (2) is securely connected to the lower housing connector (3).</p> <p>Check wires (4) for cuts, breaks, or broken insulation.</p> <p>Check connector (3) for damage or dirt.</p>	<p>Battery Pack connector broken or will not connect to lower housing connector securely.</p> <p>Wires leading from Battery Pack are cut, broken, or have cut insulation.</p>
9	Before	Upper Housing Assembly	<p>Make sure the Upper Housing (5) fits smoothly into the slot (6) on the circumference of the black exhaust grommet (7). Ensure that all fasteners (8) engage properly and secure the Upper Housing Assembly.</p>	<p>One or more fasteners are damaged and prevent the Upper Housing Assembly from being secured.</p>
10	Before & During	External Fuel System	<p>Check External Fuel System (9) for leaks or evidence of leaks, including fuel hose (10), fuel quick disconnect (11), Sediment Strainer (12) and connecting fittings (13).</p> <p>Verify that fuel solenoid assembly wires (14) are undamaged and that connectors (15) are secure.</p>	<p>There is any leakage within the heater, or there is a Class III leak anywhere. Stop operation of the heater and report leak to unit maintenance.</p>

Table 1. Operator Preventive Maintenance Checks and Services. - Continued

ITEM NO.	INTERVAL	ITEM TO BE CHECKED/SERVICED	PROCEDURE	EQUIPMENT NOT READY/AVAILABLE IF:
11	Before	Sediment Strainer	<p>Check the Sediment Strainer (12) for dirt or water.</p> <p>Rotate the bale upward while supporting the bowl. Rock the bowl slightly and remove it from the Sediment Strainer top assembly.</p> <p style="text-align: center;">NOTE</p> <p>Do not empty the fuel into a fresh fuel supply.</p> <p>Empty the fuel from the bowl into an approved container and discard. Replace the bowl, rotate the bale downward and center under the bowl. Tighten the knurled nut, taking care not to over tighten.</p>	<p>If dirt or water is present, drain the Sediment Strainer of fuel by loosening the knurled nut at the base of the Sediment Strainer bowl.</p>
12	Before	Combustion Air Inlet Assembly	<p>Check Combustion Air Inlet Assembly (16) for dirt and debris that could be sucked into heater. Ensure that there are no obstructions.</p> <p>Verify that cover (17) can be removed easily.</p>	<p>Combustion Air Inlet is obstructed.</p> <p>Cover is damaged and cannot be secured to heater.</p>

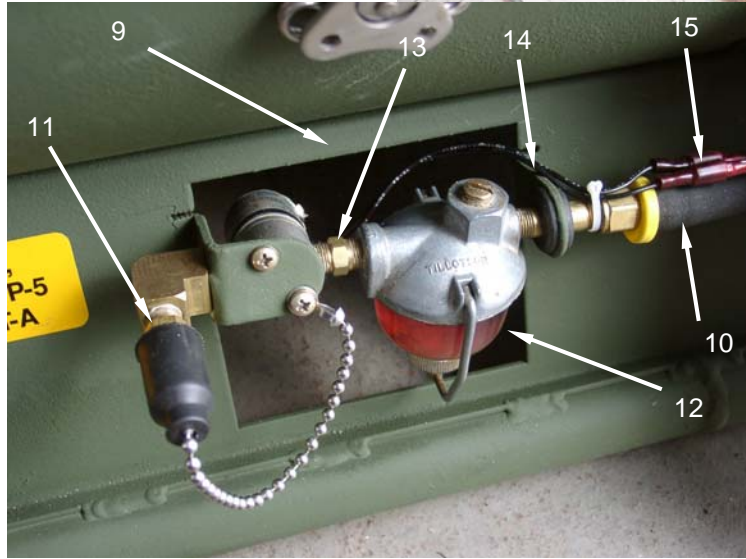
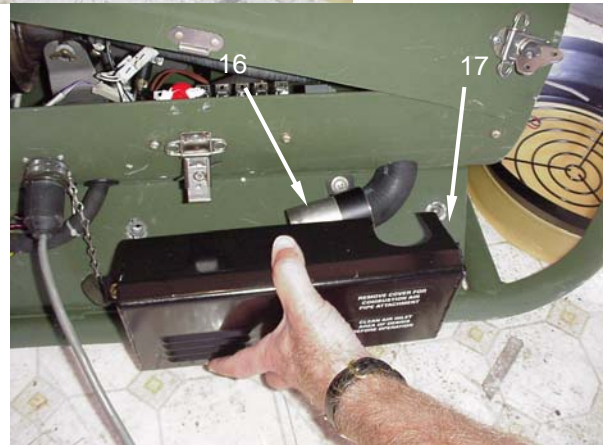
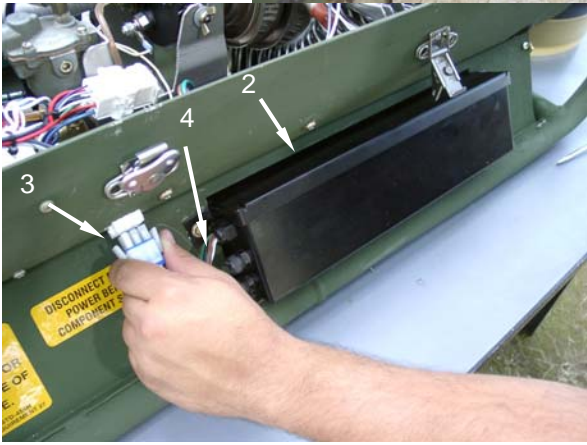

Table 1. Operator Preventive Maintenance Checks and Services. - Continued

ITEM NO.	INTERVAL	ITEM TO BE CHECKED/SERVICED	PROCEDURE	EQUIPMENT NOT READY/AVAILABLE IF:
13	Before	Manual Reset Thermostat	Remove rubber plug (1) and visually verify that the Manual Reset Thermostat switch (2) is undamaged. Replace rubber plug (1) .	Manual Reset Thermostat switch is damaged.
14	Before	Fastener Housing and Keeper Assemblies	Check that fasteners (4) and keeper plates (5) are tightly attached to duct adapters (6) and/or upper (7) and lower (8) housing assemblies.	Fasteners and keeper plates are broken and/or missing.

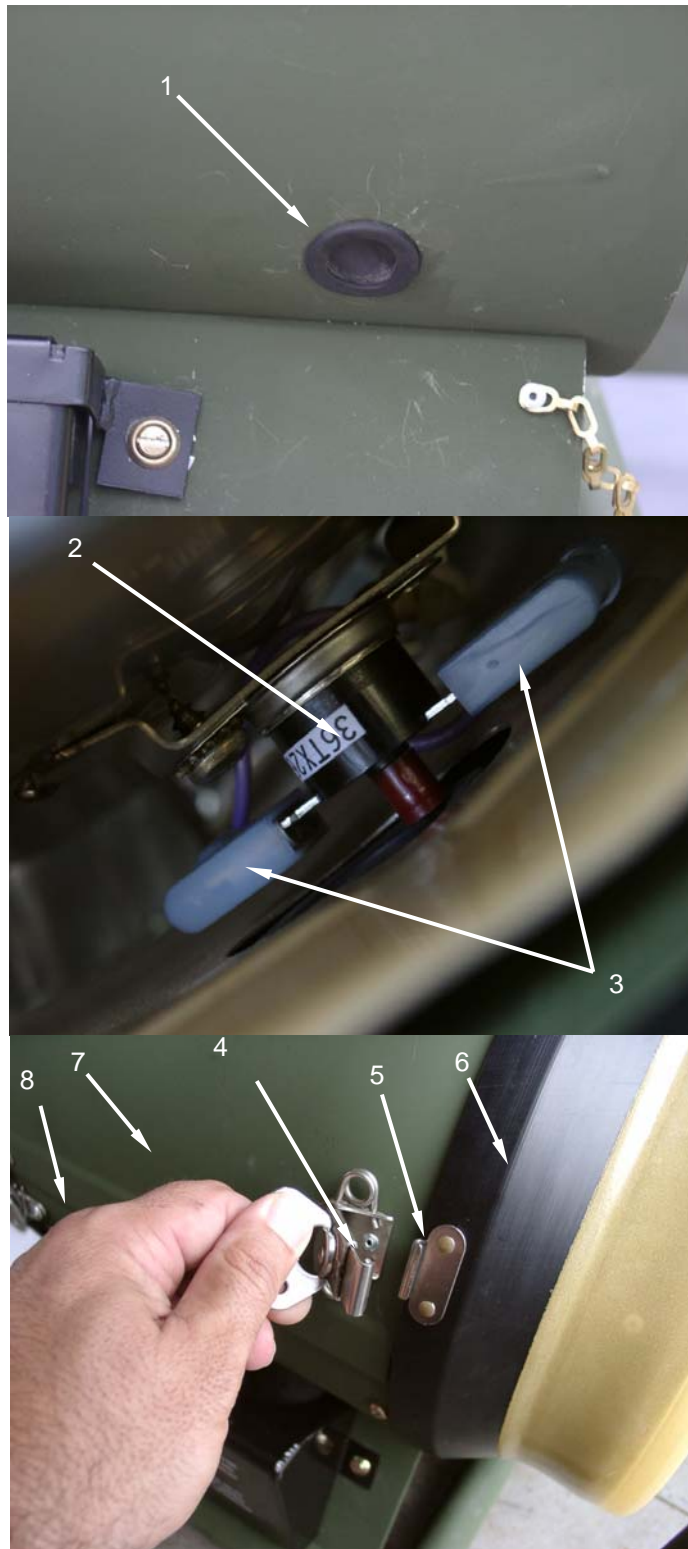

Table 1. Operator Preventive Maintenance Checks and Services. - Continued

ITEM NO.	INTERVAL	ITEM TO BE CHECKED/SERVICED	PROCEDURE	EQUIPMENT NOT READY/AVAILABLE IF:
15	After	Fuel Drain Valve (Bottom of Lower Housing)	Check that Fuel Drain Valve (1) is tightly closed.	Fuel Drain Valve leaks.
16	After	Dust Covers and Duct Adapters	Check that the two Dust Covers (2) and two Duct Adapters (3) at the ends of the heater are firmly attached to the heater.	Duct Adapters will not attach to heater.
17	Weekly	Battery Pack	<p>Verify that the battery retainer (4) is not damaged and quarter turn screws (5) are secure.</p> <p>Unscrew fuse caps (6) and remove fuses (7). Visually verify that fuses are not blown.</p> <p>Check the outer casing of the battery (8) for cracks, cuts, or other damage.</p>	<p>Battery retainer is damaged.</p> <p>Fuses are blown and there are no spares.</p> <p>The Battery Pack is cracked, cut, or damaged.</p>

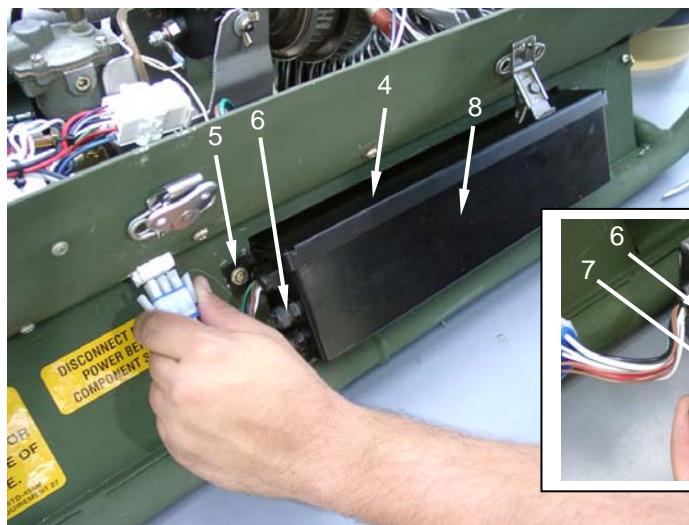
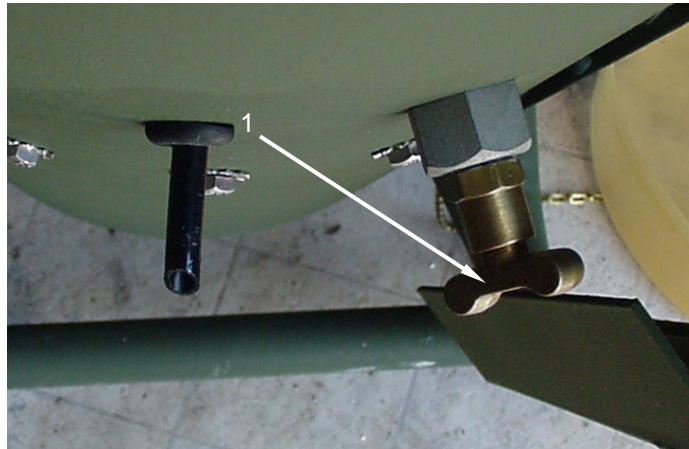

Table 1. Operator Preventive Maintenance Checks and Services. - Continued

ITEM NO.	INTERVAL	ITEM TO BE CHECKED/SERVICED	PROCEDURE	EQUIPMENT NOT READY/AVAILABLE IF:
18	Weekly	Heater Interior	<p>Release eight fasteners (1) away from their corresponding keeper plate (2). Remove upper housing assembly (3). Inspect interior of heater for:</p> <p>Any dirt or debris that could be blown through heat exchanger (4) and into the tent. Remove dirt and debris using a clean rag. Pay special attention to cooling fins (5) on the TEG that could trap bits of paper or other combustibles.</p> <p>Check for any evidence for leaks. Notify unit maintenance personnel based on leakage class described above.</p> <p style="text-align: center;">NOTE</p> <p>The heater may be operated with Class I leaks within the heater, but they must be monitored to insure they do not get worse, pose a fire hazard, or cause the heated air being ducted to the tent to smell of fuel oil.</p>	<p>Dirt or other debris present inside heater.</p> <p>Class III Leaks present inside heater.</p>
19	Weekly	Electrical Wires and Components	<p>Check electrical wires (6), connectors, (7) and components for any evidence of overheating, arcing, or burning. Notify Unit maintenance personnel.</p>	<p>Any wires or connectors broken or otherwise damaged.</p>
20	Weekly	Burner to TEG Flange Clamp	<p>Check that the Burner to TEG Flange Clamp with nut (8) is secure, and provides a leak proof seal between the burner and the TEG.</p>	<p>V-clamp with nut is loose or not secure on burner assembly and TEG. Notify Unit maintenance.</p>
21	Weekly	Wrap Cover	<p>Check that the Wrap Cover (9) is properly installed and tightly fastened down.</p>	<p>Wrap Cover is loose. Notify Unit maintenance.</p>
22	Weekly	Exhaust Grommet	<p>Check that black Exhaust Grommet (10) is present and properly installed around the combustion exhaust outlet (11) and is nestled in the cutout (12) on the lower housing assembly.</p>	<p>Grommet missing or not properly installed. Notify Unit maintenance.</p>

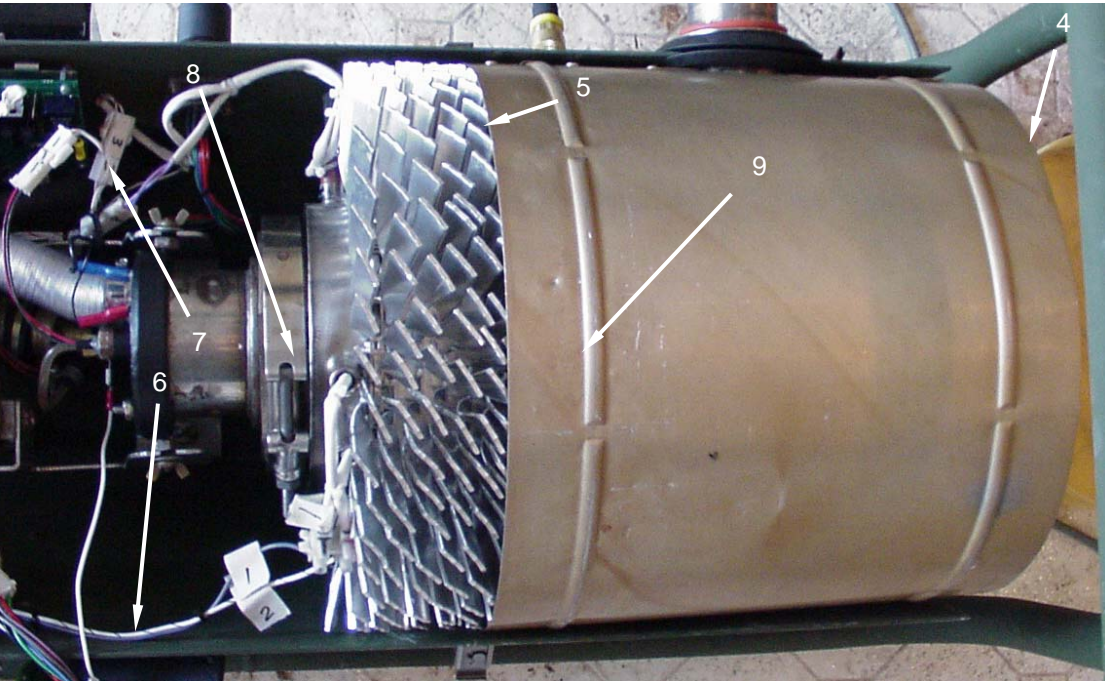
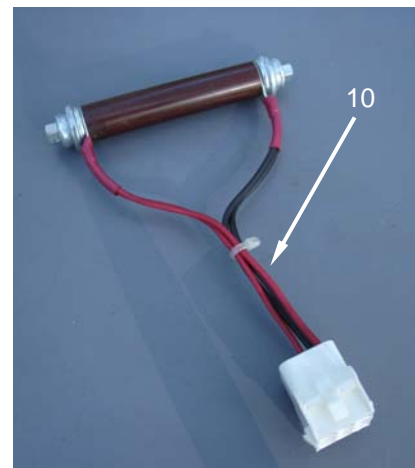
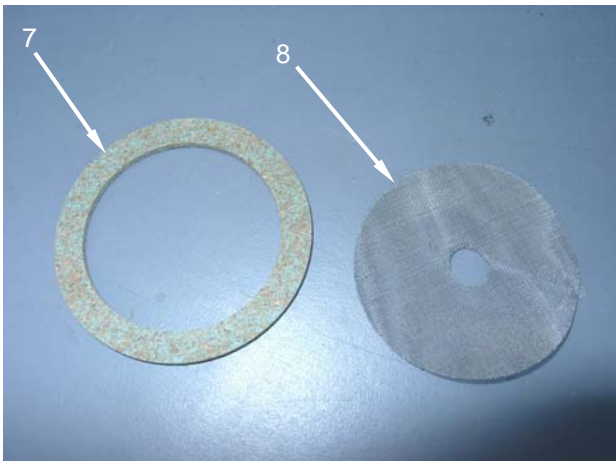
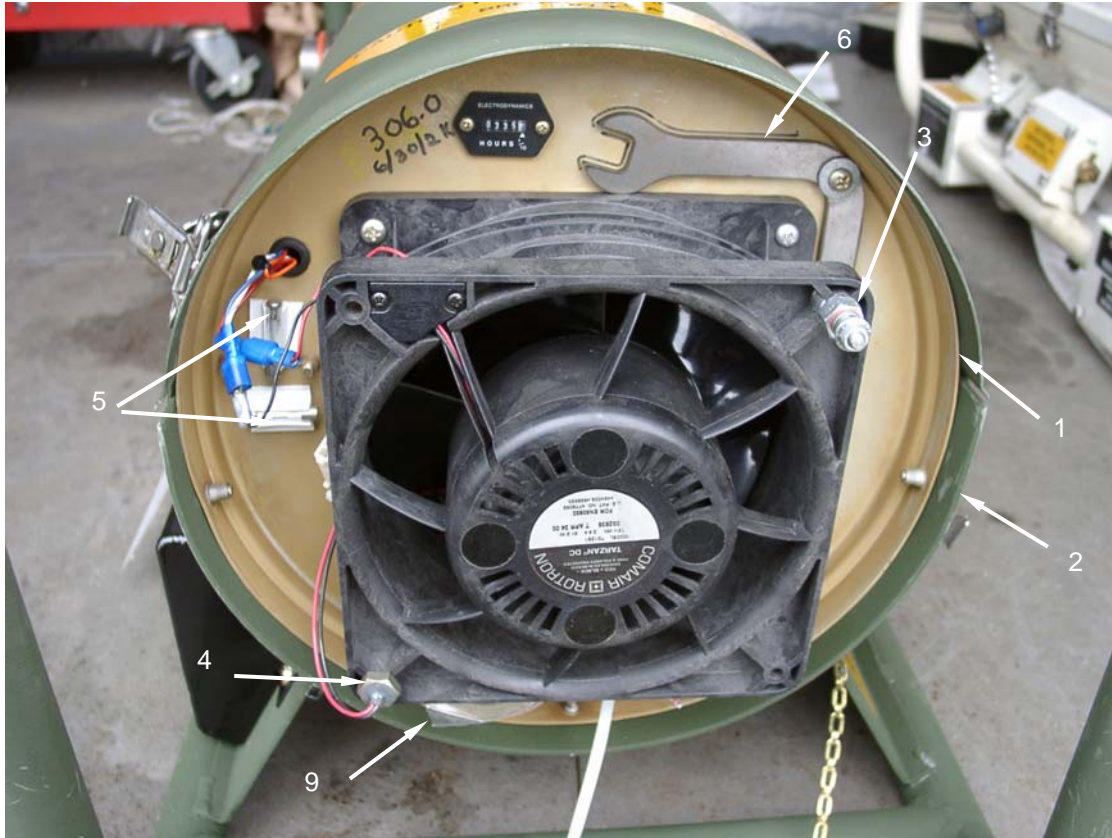

Table 1. Operator Preventive Maintenance Checks and Services. - Continued

ITEM NO.	INTERVAL	ITEM TO BE CHECKED/SERVICED	PROCEDURE	EQUIPMENT NOT READY/AVAILABLE IF:														
23	Weekly	Onboard Spares and Tool	<p>Check the spares and tool stowage area (1) within the duct adapter at the inlet end (2) of the heater. Confirm that all of the onboard spares and tool listed below are present. Order replacements for those which are missing.</p> <table border="1" data-bbox="706 695 1159 940"> <thead> <tr> <th data-bbox="706 695 1084 726">Name</th> <th data-bbox="1089 695 1159 726">Qty</th> </tr> </thead> <tbody> <tr> <td data-bbox="706 732 1084 764">Glow Plug (3)</td> <td data-bbox="1089 732 1159 764">1</td> </tr> <tr> <td data-bbox="706 764 1084 795">Flame Sensor (4)</td> <td data-bbox="1089 764 1159 795">1</td> </tr> <tr> <td data-bbox="706 795 1084 848">Battery Pack Fuses (20 Amp) (5)</td> <td data-bbox="1089 795 1159 848">2</td> </tr> <tr> <td data-bbox="706 848 1084 879">Wrench (6)</td> <td data-bbox="1089 848 1159 879">1</td> </tr> <tr> <td data-bbox="706 879 1084 911">Sediment strainer gasket (7)*</td> <td data-bbox="1089 879 1159 911">1</td> </tr> <tr> <td data-bbox="706 911 1084 940">Sediment strainer screen (8)*</td> <td data-bbox="1089 911 1159 940">1</td> </tr> </tbody> </table> <p>* stored in plastic bag (9) below fan</p> <p>Ensure that the Battery Charging Adapter (10) is included with the other accessory items in the accessory bag.</p>	Name	Qty	Glow Plug (3)	1	Flame Sensor (4)	1	Battery Pack Fuses (20 Amp) (5)	2	Wrench (6)	1	Sediment strainer gasket (7)*	1	Sediment strainer screen (8)*	1	Heater may be operated without these spares and tool.
Name	Qty																	
Glow Plug (3)	1																	
Flame Sensor (4)	1																	
Battery Pack Fuses (20 Amp) (5)	2																	
Wrench (6)	1																	
Sediment strainer gasket (7)*	1																	
Sediment strainer screen (8)*	1																	
24	During (Every 250 Operating Hours)	Burner	If the heater is operated with diesel fuel or if experiencing burner maintenance Fault codes, notify Unit maintenance to perform the service procedure for the burner. Refer to WP 0037 00.	Excessive carbon buildup is present on the vaporizer assembly.														



**SPACE HEATER, CONVECTIVE (SHC)
OPERATOR MAINTENANCE PROCEDURES**

INTRODUCTION

This section contains Operator Maintenance applicable to the SHC as authorized by the Maintenance Allocation Chart (MAC) in WP 0044 of this manual.

All maintenance procedures in this section can be performed by one person unless otherwise indicated.

Read all **WARNINGS**, **CAUTIONS**, and **NOTES** carefully before attempting the procedures. This includes the warnings at the front of this manual.

Each maintenance item will include a heading which lists the action to be taken, the tools and parts/materials required, and the condition the equipment must be in to perform the action.

END OF WORK PACKAGE

OPERATOR MAINTENANCE
SPACE HEATER, CONVECTIVE
(NSN 4520-01-431-8927)

FLAME SENSOR
REPLACE

INITIAL SETUP**Tools**

Wrench (Table 2, Item 2, WP 0044 00)

Materials/Parts

Flame sensor (Item 9, WP 0067 00)

Equipment Condition

Heater shut down and all advisory lights off. (WP 0006 00)

In-tent controller assembly disconnected from heater. (WP 0006 00)

Fuel supply disconnected. (WP 0006 00)

Battery disconnected. (WP 0018 00)

CAUTION

Disconnect battery connector. Before performing any maintenance actions, be sure to disconnect the battery to prevent component failure. Failure to comply may result in damage to electrical components.

REPLACE

1. Disconnect battery pack connector **(1)** from lower housing assembly.
2. Remove the upper housing assembly **(2)** by first removing the two dust covers **(3)** at the inlet and outlet ends of the heater.
3. Remove the two duct adapters **(4)** at the inlet and outlet end of the heater by releasing the two fastener housings **(5)** from the fastener keepers **(6)**.
4. Remove the upper housing assembly **(2)** by releasing the remaining fastener housings **(7)** from their corresponding fastener keepers **(8)**. Lift and remove the upper housing assembly **(1)**. Set the upper housing assembly aside.

NOTE

Spares and onboard tools are located inside the duct adapter located on the inlet side of the heater near the heated air blower assembly.

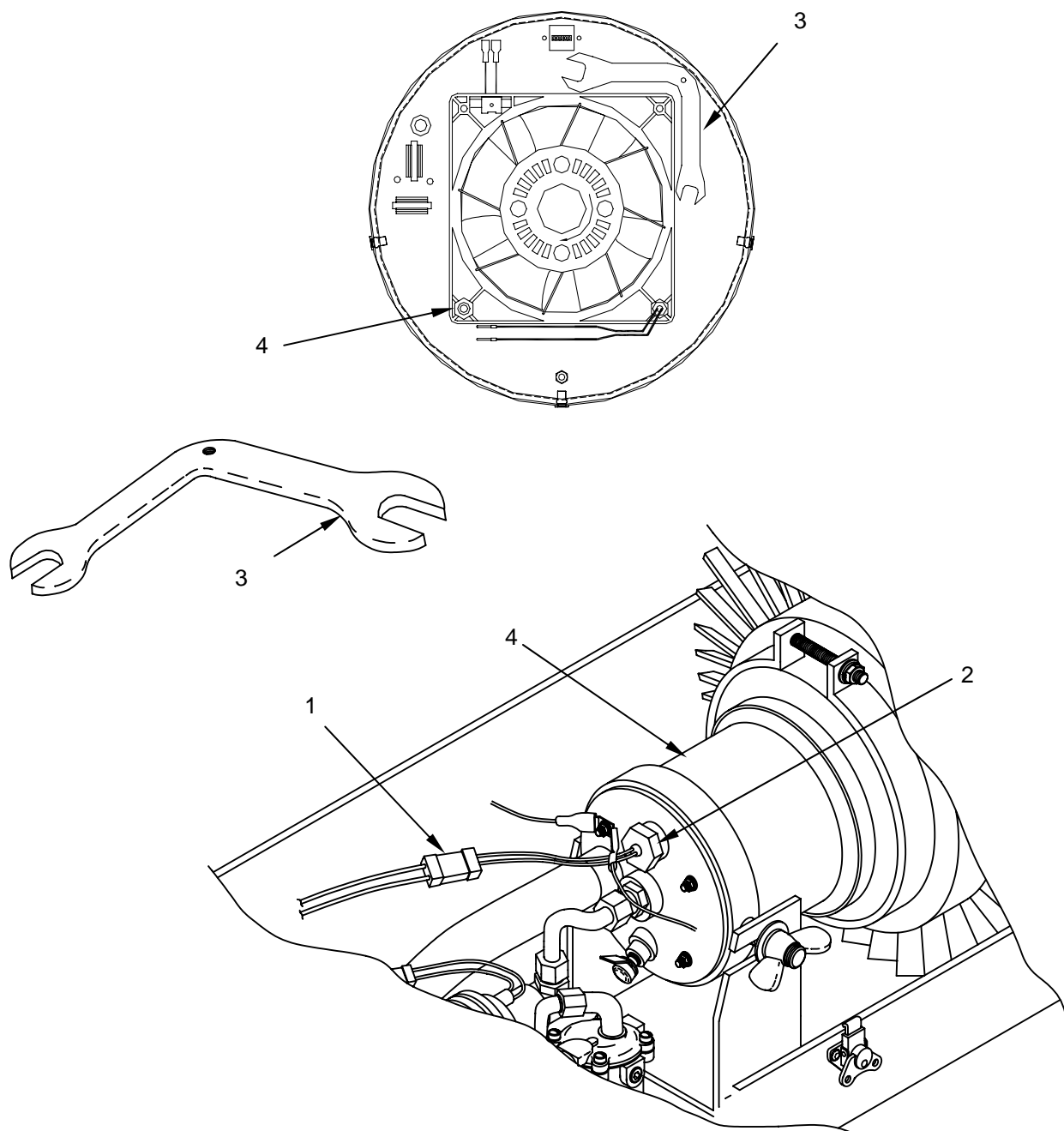

END OF WORK PACKAGE

OPERATOR MAINTENANCE
SPACE HEATER, CONVECTIVE
(NSN 4520-01-431-8927)

GLOW PLUG
REPLACE

INITIAL SETUP**Tools**

Wrench, (item 2, WP 0044 00)

Materials/Parts

Glow Plug, (item 10, WP 0067 00)

Equipment Condition

Heater shut down and all advisory lights off. (WP 0006 00)

In-tent controller assembly disconnected from heater. (WP 0006 00)

Upper housing assembly removed (WP 0030 00).

Fuel supply disconnected. (WP 0006 00)

Battery disconnected. (WP 0018 00)

CAUTION

Disconnect battery connector. Before performing any maintenance actions, be sure to disconnect the battery to prevent component failure. Failure to comply may result in damage to electrical components.

REPLACE

1. Disconnect battery **(1)**.
2. Disconnect electrical lead **(2)** from glow plug **(3)**.
3. Using wrench **(4)** supplied with the heater, loosen and remove glow plug **(3)** from burner assembly **(5)** by turning in a counterclockwise direction.
4. Locate and remove a new glow plug **(6)** from the spare storage area **(7)** at the breathable air inlet end of the heater. Screw the replacement glow plug **(3)** in clockwise direction into burner assembly **(5)** and reconnect electrical lead **(2)**.

NOTE

Spares and onboard tools are located inside the duct adapter located on the inlet side of the heater near the heated air blower assembly.

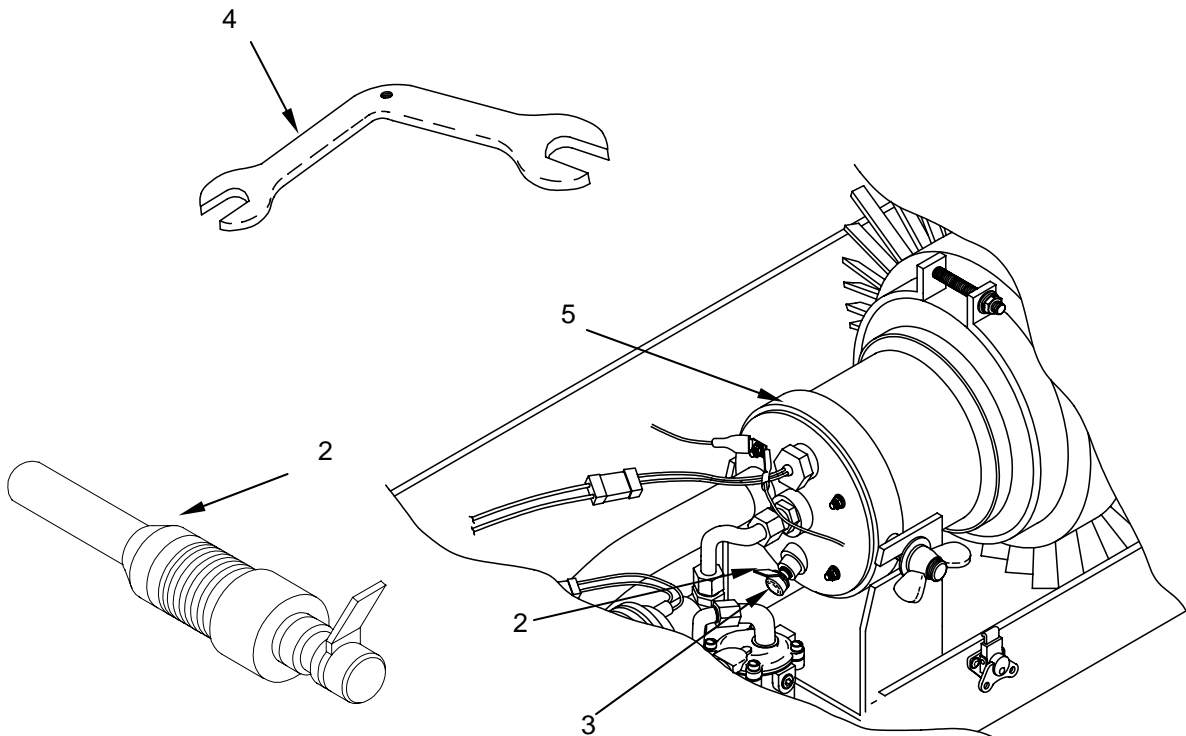
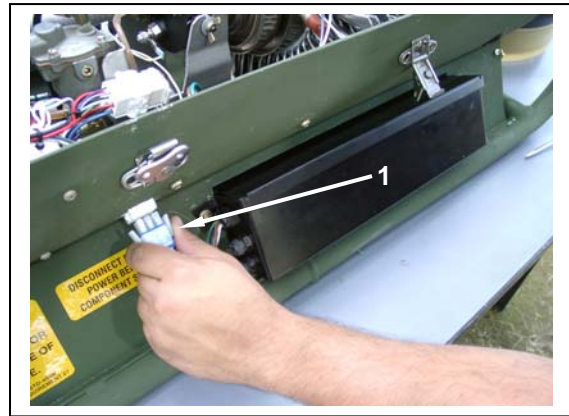
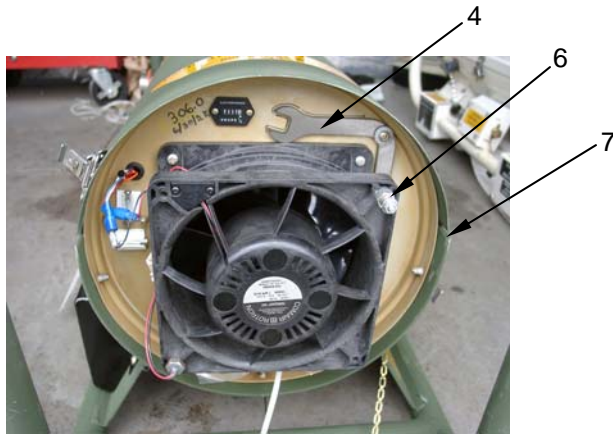

END OF WORK PACKAGE

TM 10-4520-262-12&P

CHAPTER 5
UNIT
MAINTENANCE INSTRUCTIONS
SPACE HEATER, CONVECTIVE

**SPACE HEATER CONVECTION (SHC)
UNIT PREVENTIVE MAINTENANCE CHECKS AND SERVICES**

GENERAL

This section lists the preventive checks and services to be performed quarterly by Unit Maintenance personnel. Refer to Operator PMCS WP 0010 00 for an explanation of PMCS procedures.

PMCS TABLE

The accompanying table provides a listing of PMCS to be performed by Unit personnel. It includes the following:

Item Number Column. This column is a list of every check and service task in the PMCS. They are numbered in logical order of performance regardless of the interval. This column is to be used as a source of item numbers for the Number Column on DA Form 2404, Equipment Inspection and Maintenance Worksheet, in recording results of PMCS.

Interval Column. This column indicates the interval at which a specific item needs to be checked or serviced.

Item To Be Checked or Serviced Column. This column provides the name of the item to be checked or serviced.

Procedure Column. This column describes the procedures used to check or service an item. It includes all the information required to perform the checks or services.

Not Fully Mission Capable If: Column. This column indicates conditions under which the heater is not capable of performing its intended mission.

LEAKAGE DEFINITIONS FOR UNIT PMCS

It is necessary for you to know how fuel leaks affect the status of the heater. Following are classes of leaks you need to know to determine the operational status of the heater. Learn these leakage class definitions. Remember when in doubt, notify your supervisor.



WARNING

Seat the Fuel can adapter kit. The kit must be fully seated to prevent fuel leakage. Clean up all fuel spills. No leakage of any type is permitted within the heater. No leakage of any type is permitted within the area or compartment being heated. Leakage may present a fire and/or a health hazard. Failure to comply may result in serious injury or death.

NOTE

Leaking or spilled fuels will harm the environment. Follow all local requirements when cleaning up all fuel spills.

Heater operation is allowed if:

Class I or Class II leaks occur in fuel supply lines external to the heater. And, such leakage does not present a fire or health hazard. Class III leaks shall be reported immediately to your supervisor.

CLASS I - Slight seepage of fuel, but not great enough to form a drop. Indicated by slight wetness or discoloration.

CLASS II - Seepage of fuel great enough to form drops but not great enough to cause drops to drip from the item being checked.

CLASS III - Leakage of fuel great enough to form drops that fall from the item being checked.

NOTE

If the equipment must be kept in continuous operation, do only the procedures that can be done without disturbing operation. Make complete checks and services when the equipment is shut down.

Table 1. Operator Preventive Maintenance Checks and Services.

ITEM NO.	INTERVAL	ITEM TO BE CHECKED/SERVICED	PROCEDURE	EQUIPMENT NOT READY/AVAILABLE IF:
			<p>NOTE</p> <p>All necessary PMCS may be accomplished by the operator.</p>	

END OF WORK PACKAGE

**SPACE HEATER, CONVECTIVE (SHC)
UNIT MAINTENANCE PROCEDURES**

GENERAL

The procedures in this section have been arranged in order in which the items appear in the Unit (0) Maintenance level column on the Maintenance Allocation Chart (MAC), which is provided in WP 0041 00. Step by step procedures have been provided for all actions authorized to be performed by the Unit in Chapter 4.

CAUTION

Disconnect battery connector. Before performing any maintenance actions, be sure to disconnect the battery to prevent component failure. Failure to comply may result in damage to electrical components.

WIRING

General. Preferred repair methods consist of replacing wires, terminals, connectors, etc., rather than splicing wires, bending ends to form terminals, and other makeshift procedures, although the latter may be appropriate for emergency field repairs.

Soldering Connections. Wire connections must be made mechanically sound before they are soldered. Solder alone does not provide sufficient strength to prevent breakage. Joining surfaces of connections to be soldered must be clean and bright. If a separate flux is used, it should be rosin base flux and should be brushed onto the joint before soldering. If a flux-core solder is used, it should be a rosin core electrical solder. If uncured solder is used, it should be a lead-tin solder. Wires should always be heated to the point at which the solder will melt completely and flow into all parts of the joint. Excessive build up of solder "gobs" on the joint should be avoided or removed.

Insulating Joints. The preferred method of insulating electrical joints is by the use of heat-shrink tubing. To apply, cut a piece of heat-shrink tubing of suitable diameter to a one-inch length for covering joints at terminals or connectors, or to a length about 1/2 inch (1.3 cm) longer than the joint to be insulated, and slide the tubing over the wire before making the joint. After the joint is made, slide the tubing so that it covers the joint, and shrink in place with moderate heat.

Splicing Wires. To repair broken or cut wires that are otherwise sound, the mating ends can be stripped and spliced. A commercial butt splice can be crimped onto the ends to join them, or a "Western Union" wire splice can be made. The latter is made by stripping 1/4-1/2 inch (6.5-12.7 mm) of insulation from the wire ends, holding the ends parallel and facing opposite directions, then twisting each end around the other wire at least three turns. Solder and apply insulation as described above.

Crimping Terminals. To install a terminal on the end of a wire, strip 1/4-1/2 inch (6.5 12.7 mm) of insulation from the end of the wire, apply a one-inch piece of heat-shrinking tubing (if the terminals are of the non-insulated type) and insert wire end into the shank of the terminal. Crimp the shank, and install heatshrink tubing, if necessary.

CLEANING AND INSPECTION OF ANTIFRICTION BEARINGS

Refer to TM 9-214, Inspection, Care, and Maintenance of Antifriction Bearings.

CLEANING AND INSPECTION OF MECHANICAL PARTS**WARNING**

Cleaning solvents are flammable, toxic, and hazardous to eyes, skin, and respiratory tract. Skin/eye protection is required. Avoid unprotected or repeated/prolonged contact. If contact with eyes is made, immediately flush with clean water and get medical first aid. Failure to comply may result in serious injury to personnel.

Use only in well ventilated areas. Keep away from open flames or other sources of ignition.

Compressed air used for cleaning purposes will not exceed 30 psi (kPa). Use only with effective personal eye/face protective equipment.

Clean metal parts with alcohol. Thoroughly dry the parts with compressed air, observing all safety precautions.

Fibrous or rubber parts can generally be cleaned with warm, soapy water and dried with compressed air.

Inspect metal parts for cracks, breaks, bends, worn edges, and rough bearing surfaces. Damage that alters the part or its function is cause for replacement of that part.

GENERAL REPAIR

Repair the SHC to normal operating condition by replacing or repairing a defective component and/or by needed adjustments.

Cleaning and lubrication is sometimes all that is needed to return an item to operating condition.

Remove and replace only those items necessary to make repairs. After replacing the defective components, ensure that the SHC operates correctly.

To paint metal, sand bare metal areas with sandpaper and refinish with primer and olive drab paint. Refer to TM 43-0139 for proper painting instructions. Allow paint to dry between coats.

END OF WORK PACKAGE

UNIT MAINTENANCE**SPACE HEATER, CONVECTIVE****(NSN 4520-01-431-8927)****IN-TENT CONTROLLER ASSEMBLY
INSPECT, TEST, REPLACE**

INITIAL SETUP**Tools**

Tool Kit, General Mechanics (Item 1, WP 0044 00)

Materials/Parts**Personnel Required**

One

Equipment ConditionHeater shut down and all advisory lights off. (WP 0006 00)

INSPECT

1. Inspect the In-tent Controller Assembly connector **(1)** for cracks, dents to the outer collar, dirt in the contacts, or any other damage that would prevent the connector **(1)** from making a good electrical connection with the in-tent controller cable assembly **(2)**.
2. Inspect the ON-OFF switch **(3)** and LOWER-HIGHER control **(4)** to ensure proper operation.
3. Ensure that each of the advisory lights **(5)** operate properly.
4. Ensure that all informational labels **(6 and 7)** are present and legible.

TEST

Using a multimeter, perform a short circuit test across all terminals **(8)** of the connector **(1)**. For example, pin A to pin B, A to C, A to D, etc. Followed by B to A, B to C, B to D, etc. There should not be shorts across any of the pins. If shorts exist, replace the in-tent controller assembly.

REPLACE

1. To replace the in-tent controller assembly **(9)**, unscrew the outer collar **(10)** of the in-tent controller assembly cable **(2)** and disconnect cable from in-tent controller assembly **(9)**.
2. Connect in-tent controller cable **(2)** to new in-tent controller assembly **(9)**.
3. Tighten outer collar **(10)** of in-tent controller assembly cable **(2)** securely.

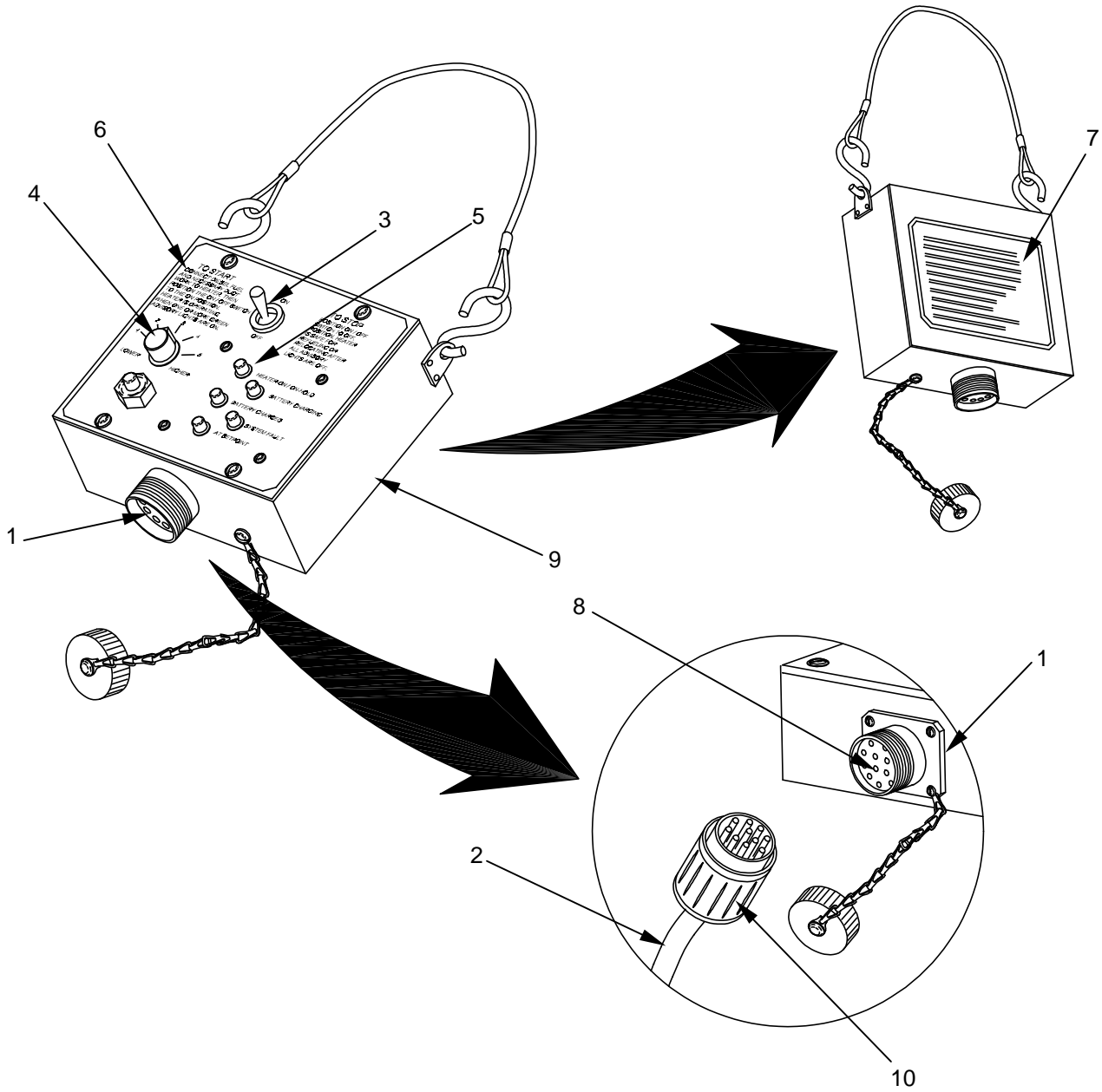

END OF WORK PACKAGE

UNIT MAINTENANCE

SPACE HEATER, CONVECTIVE

(NSN 4520-01-431-8927)

IN-TENT CONTROLLER CABLE ASSEMBLY
INSPECT, TEST, REPLACE

INITIAL SETUP

Tools

Tool Kit, General Mechanics (Item 1, WP 0046 00)

Materials/PartsPersonnel Required

One

Equipment Condition

Heater shut down.

In-tent controller assembly cable disconnected from heater and in-tent controller assembly connector.

INSPECT

Inspect the In-tent Controller Cable Assembly connector **(1)** for cracks, dents to the outer collar, dirt in the contacts, or any other damage that would prevent the connector **(1)** from making a good electrical connection with the in-tent controller assembly connector **(2)**.

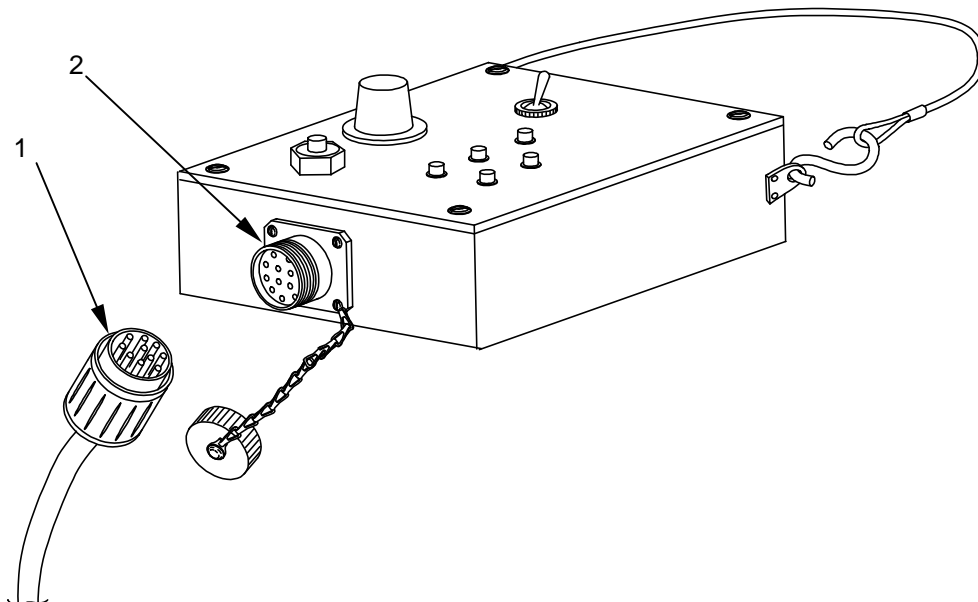

TEST

1. Using a multimeter, perform a continuity check from pin A at one end of cable to pin A at opposite end of cable. Repeat for all pins. Ensure that there is continuity through the cable.
2. Using a multimeter, perform a short circuit test across all terminals of the connector. For example, test from pin A to pin B, A to C, A to D, etc. Followed by B to A, B to C, B to D, etc. There should not be shorts across any of the pins. If shorts exist, replace the in-tent controller assembly cable.
3. If there is a lack of continuity through the cable or shorts within either of the connectors, replace the in-tent controller cable assembly.

REPLACE

1. Ensure that the in-tent controller cable assembly has been completely disconnected from the heater and the in-tent controller assembly.
2. Connect new cable to the heater and to the in-tent controller assembly. Secure connectors at both ends of in-tent controller assembly cable.

END OF WORK PACKAGE

UNIT MAINTENANCE
SPACE HEATER, CONVECTIVE

(NSN 4520-01-431-8927)

BATTERY PACK ASSY
INSPECT, TEST, SERVICE, REPLACE

INITIAL SETUP

Tools

Tool Kit, General Mechanics (Item 1, WP 0044 00)

Materials/Parts

Personnel Required

One

Equipment Condition

Heater shut down and all advisory lights off. (WP 0006 00)

In-tent controller assembly disconnected from heater. (WP 0006 00)

CAUTION

Disconnect battery connector. Before performing any maintenance actions, be sure to disconnect the battery to prevent component failure. Failure to comply may result in damage to electrical components.

INSPECT

1. Disconnect battery pack assembly **(1)**.
2. Inspect battery pack electrical connector **(2)**. Ensure that connector **(2)** is not cracked or damaged in any way. Ensure that all wires **(3)** leading from battery pack **(1)** to connector housing are free of cuts, abrasions, or any other damage that would expose bare wire.
3. Inspect the two fuse holders **(4)** on the side of the battery pack **(1)** and ensure that there are no cracks or other damage that would prevent the fuse holders from securing the fuse and maintaining proper electrical contact.
4. Ensure that there are no cracks, cuts, or other damage to the outer casing of the battery pack **(1)**.
5. If there is any damage to the connector **(2)**, fuse holders **(4)**, or wiring **(3)**, the battery pack should be replaced.

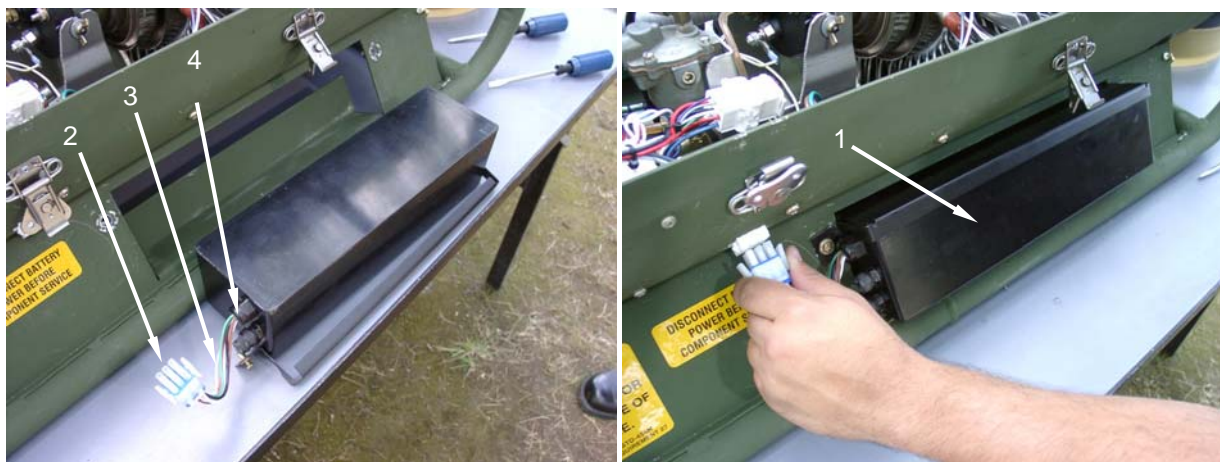

TEST

1. Before replacing the battery pack, ensure that the two fuses **(1)** are in good electrical working order by removing them from the fuse holders **(2)** on the left side of the battery pack **(3)** and testing for continuity with a multi-meter.

NOTE

Continuity through the fuse ensures that it is in good electrical working order.

2. If there is no continuity through the fuse, replace it with a known good fuse from the on-board spare parts **(4)** located at the inlet end **(5)** of the heater. If the fuses are both in good electrical working order and the battery pack is not supplying power to the heater.
3. Check the battery voltage without a load. There are two battery circuits in the battery pack.
4. Use a voltmeter to check the voltage on one battery circuit in the pack by inserting the voltmeter probes into the red and black wire pockets in the battery connector **(6)**. It should read 12.5 to 13.0 volts.
5. Check the other battery circuit in the pack by inserting the voltmeter probes in the green and white wire pockets in the battery connector **(6)**. It should read 12.5 to 13.0 volts.
6. If either of the two battery circuits in the pack does not read 12.5 to 13.0 volts, recharge the battery.

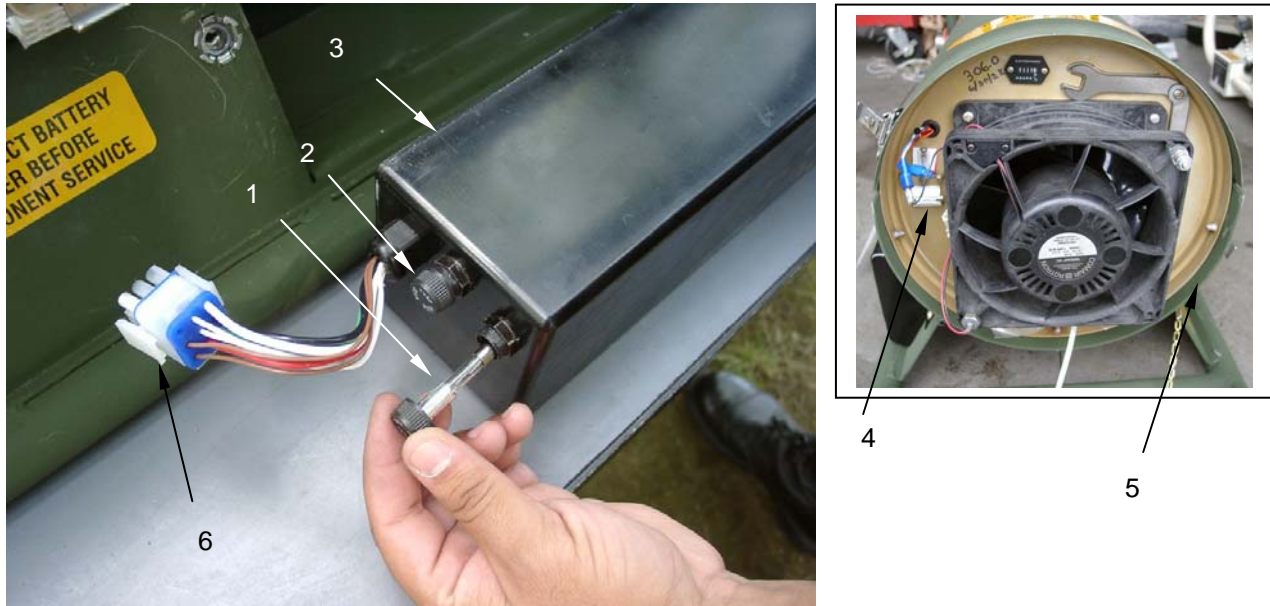

SERVICE

Under normal conditions, the Space Heater, Convective is responsible for recharging the on-board battery pack. However, there may be some instances where it is required that the battery be recharged using a commercially available 115 VAC to 12 VDC charger. To accomplish this, a battery-charging adapter has been supplied with the heater that permits the connection of a charger to the battery pack.

CAUTION

Do not permit the battery charger terminals to come in contact with the metal casing of the heater. Failure to comply may cause damage to the charger, battery pack assembly, or the electrical components.

NOTE

No grounding is necessary when using the battery-charging adapter.

1. To charge the battery (1) with a commercial 115 VAC to 12 VDC battery charger (5), disconnect the battery connector (2) from the heater and engage the connector on the end of the battery-charging adapter with the connector on the battery pack.
2. Connect the positive (+) lead of the battery charger (5) to the red (+) wire (3) of the battery-charging adapter and the negative (-) lead of the battery charger (5) to the black (-) wire (4) of the battery-charging adapter.

CAUTION

Ensure battery charging adapter is set to 12 VDC for charging.

3. Once the battery charger (5) is connected to the battery-charging adapter properly, turn on the power to the battery charger.

NOTE

Depending upon the battery temperature, recharge time for the battery will be approximately 30 minutes. The battery will take longer to recharge in cold weather conditions.

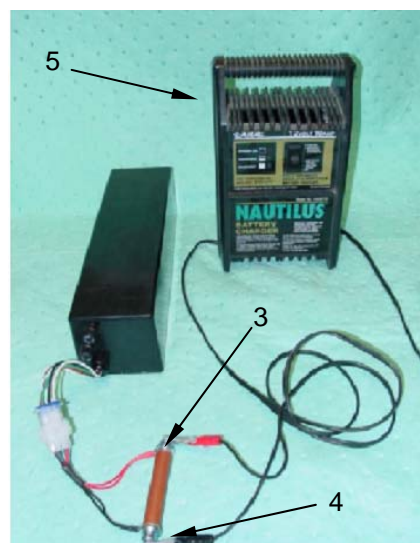
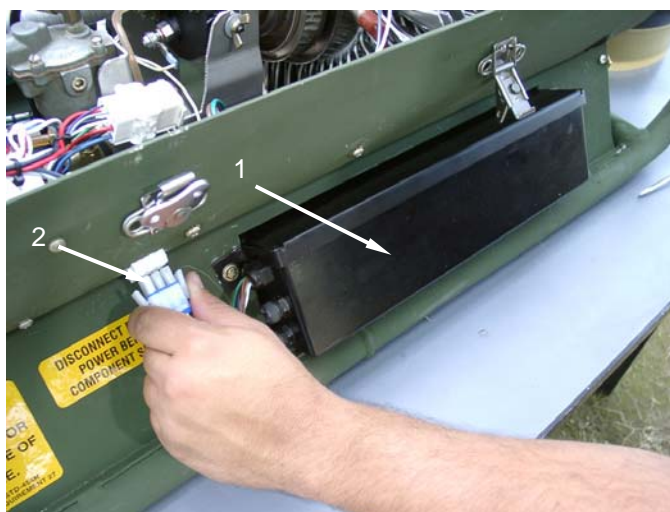

CHARGING THE BATTERY USING A NATO CHARGING SYSTEM

Under normal conditions, the SHC-35K is responsible for recharging the on-board battery pack. If necessary, a NATO charging system cable (1) with integral transformer may be used to charge the battery on the SHC-35K.



NOTE

It may be necessary to remove the battery from the heater in order to use the NATO charging system. If so, notify Unit maintenance.

1. To charge the battery (2) using a NATO charging system (1), disconnect the battery connector (3) from the heater and engage the connector (4) on the end of the NATO charging adapter with the connector on the battery pack.
2. Plug the slave connection (5) into the matching receptacle on the vehicle or equipment used to provide electrical power.
3. Verify that the charging unit green power light (6) is blinking, indicating that the NATO charging system (1) is charging.

NOTE

Depending upon the battery temperature, recharge time for the battery will be approximately 30 minutes. The battery will take longer to recharge in cold weather conditions

4. When the charging unit green power light **(6)** stops blinking and stays lit, this indicates that the battery is charged.
5. Disconnect the NATO charging system **(1)**, and reconnect the battery connector to the heater.



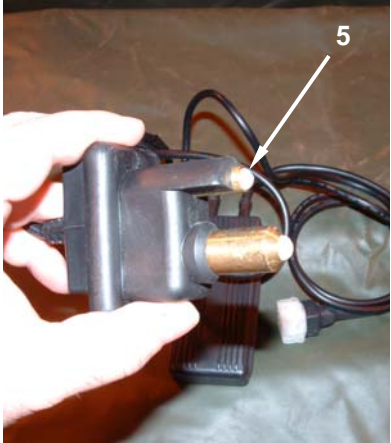
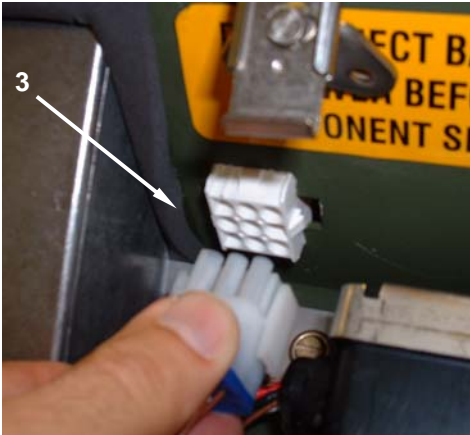

REPLACE

1. Before replacing the battery pack, an attempt should be made to recharge the battery pack in accordance with the Service section of this work package. If the battery is incapable of retaining a charge and will not start the heater, it should be replaced.
2. To remove the battery pack **(1)**, remove the battery pack retainer **(2)** by removing the two screws **(3)** on either side of the retainer **(2)**. Remove the retainer.
3. Disconnect the battery pack connector **(4)** by unplugging from portion of connector mounted in side of heater.
4. Slide the battery pack **(1)** out of the recess **(5)** on the side of the heater.
5. Dispose of the battery pack **(1)** in accordance with appropriate military and/or local regulations.
6. Install a new battery pack **(1)** into the recess **(5)** on the side of the heater. Be sure to orient the connector **(4)** on the side of the battery pack so that it aligns with the connector **(6)** installed on the side of the heater. Engage both halves of the connector and ensure that are firmly mated.
7. Install the retainer **(2)** in place over the battery pack **(1)**. Install and secure the two screws **(3)** that secure the retainer.

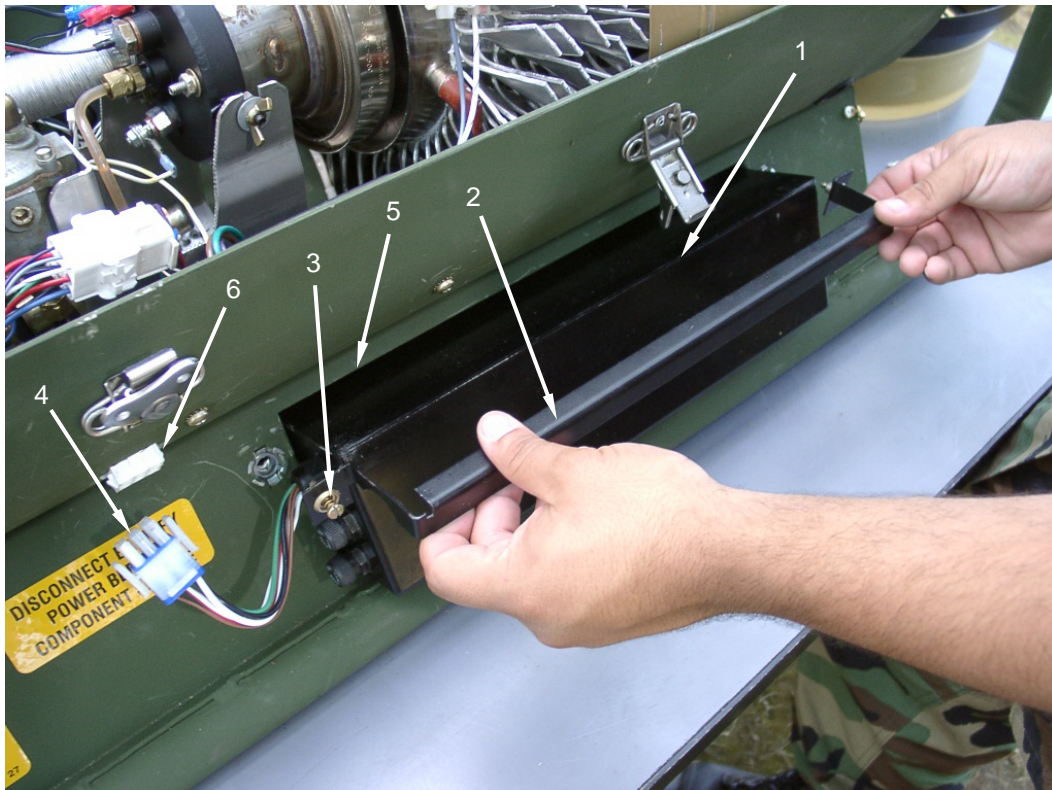
**END OF WORK PACKAGE**

UNIT MAINTENANCE
SPACE HEATER, CONVECTIVE

(NSN 4520-01-431-8927)

5FUEL SUPPLY QUICK DISCONNECT
INSPECT, REPLACE

INITIAL SETUP**Tools**

Tool Kit, General Mechanics (Item 1, WP 0044 00)

Personnel Required

One

Materials/Parts

Rags (Item 5, WP 0067 00)

Sealant, thread (Item 3, WP 0067 00)

Equipment Condition

Heater shut down and all advisory lights off. (WP 0006 00)

In-tent controller assembly disconnected from heater. (WP 0006 00)

Battery disconnected. (WP 0006 00)

Fuel supply disconnected. (WP 0006 00)

CAUTION

Disconnect battery connector. Before performing any maintenance actions, be sure to disconnect the battery to prevent component failure. Failure to comply may result in damage to electrical components.

INSPECT

Inspect the fuel supply quick disconnect **(1)** to ensure there are no cracks, dents, or other damage that would prevent the external fuel hose from attaching securely to the quick disconnect. There should be no fuel leaks when the fuel hose is attached.

REMOVE

1. To remove the fuel supply quick disconnect **(1)**, use a wrench and loosen the fuel supply quick disconnect from the elbow fitting **(2)** that is attached to the fuel solenoid valve **(3)**.
2. Remove the fuel supply quick disconnect.

REPLACE

1. Clean all residual sealant that may be present inside the elbow **(2)**.
2. Apply new sealant to the threads **(4)** of the fuel quick disconnect **(1)**.
3. Install the fuel quick disconnect into the elbow fitting **(2)**. Tighten securely.

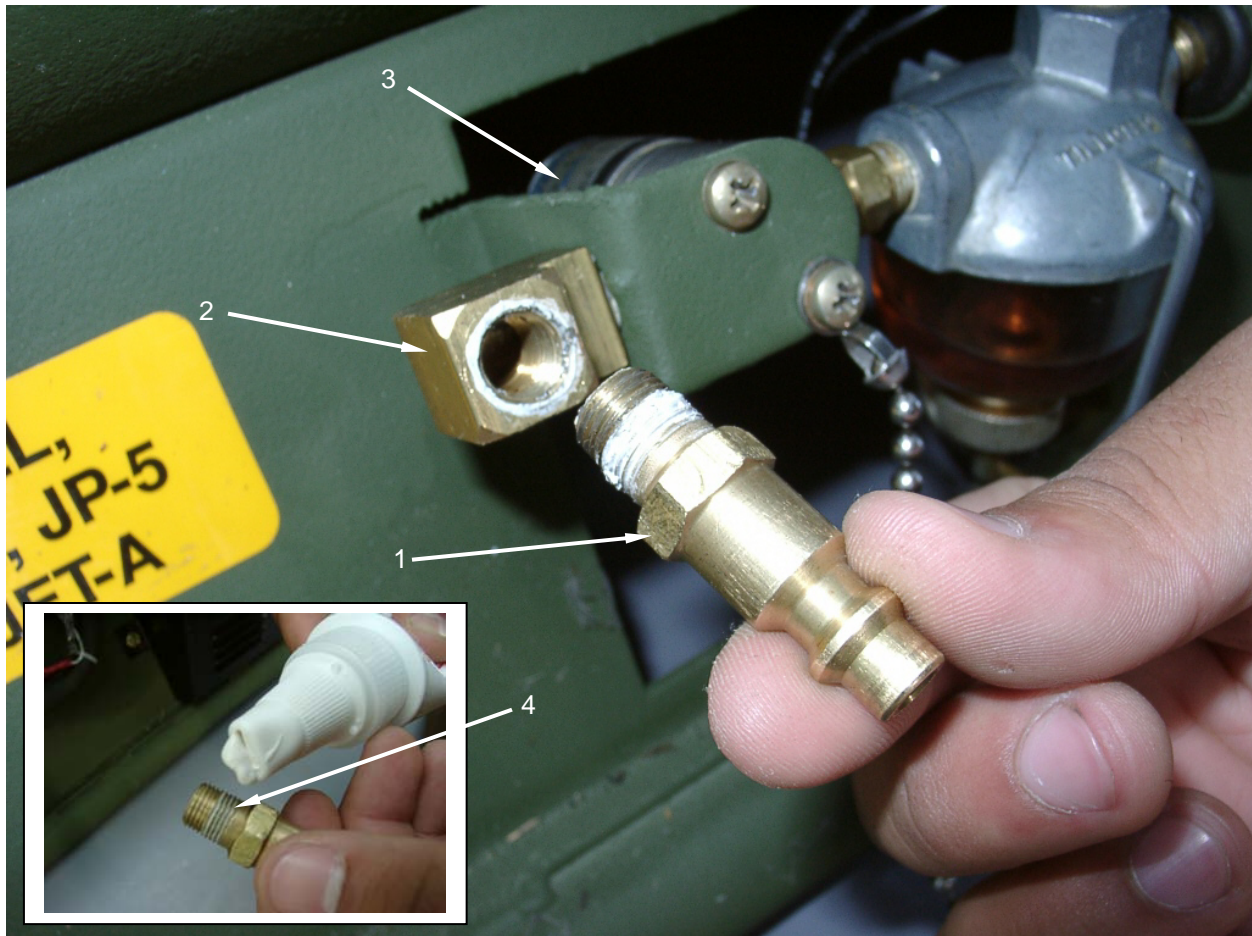
**END OF WORK PACKAGE**

UNIT MAINTENANCE

SPACE HEATER, CONVECTIVE

(NSN 4520-01-431-8927)

**FUEL SOLENOID VALVE AND SEDIMENT STRAINER ASSEMBLY
INSPECT, SERVICE, REPLACE**

INITIAL SETUP**Tools**

Tool Kit, General Mechanics (Item 1, WP 0044 00)

Materials/Parts

Gasket (Item 11, WP 0067 00)

Screen (Item 12, WP 0067 00)

Rags, Wiping, Clean (Item 5, WP 0067 00)

Sealant, Thread (Item 3, WP 0067 00)

Mat, Petroleum Absorbent (Item 15, WP 0067 00)

Wrap, Tie (Item 16, WP 0067 00)

Personnel Required

One

Equipment Condition

Heater shut down all advisory lights off. (WP 0006 00).

In-tent controller assembly disconnected from heater. (WP 0006 00)

Battery disconnected. (WP 0018 00)

Fuel supply disconnected. (WP 0006 00)

CAUTION

Disconnect battery connector. Before performing any maintenance actions, be sure to disconnect the battery to prevent component failure. Failure to comply may result in damage to electrical components.

INSPECT

1. Inspect the sediment strainer **(1)** for any cracks, dents, or other damage that would restrict the flow of fuel from the fuel solenoid valve **(2)** to the fuel hose **(3)**.
2. Ensure that there are no fuel leaks at the fittings **(4)** or around the bowl area **(5)** of the strainer.
3. Inspect the fuel solenoid valve **(2)** for any cracks, dents, or other damage that would inhibit its proper operation or restrict the flow of fuel from the fuel solenoid valve **(2)** to the sediment strainer **(1)**.
4. Ensure that the wires **(6)** protected by the wire loom **(7)** and leading to the fuel solenoid valve **(1)** do not have any cuts or abrasions.
5. Inspect the connectors **(8)** for any cracks or other damage that would prevent the connectors from having a secure electrical connection.

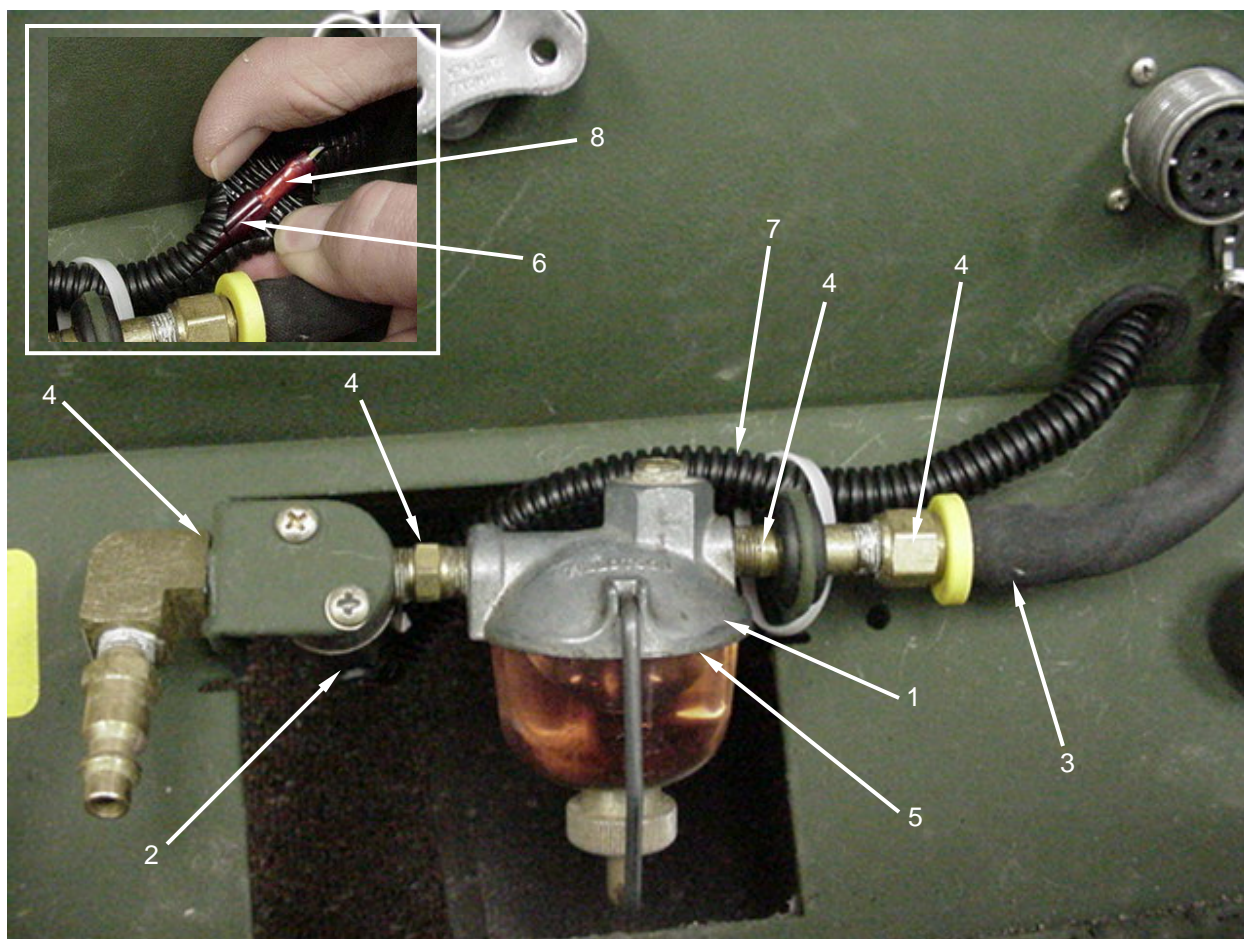

SERVICE

1. To clean and service the sediment strainer (1), loosen the knurled nut (2) at the base of the sediment strainer bowl (3).
2. Rotate the bale (4) to the right and upward while supporting the bowl (3).
3. Rock the bowl (3) slightly and remove it from the sediment strainer top assembly (5).
4. Empty the fuel from the bowl (3) into an approved container and discard. Do not empty the fuel into a fresh fuel supply.
5. Remove the gasket (6) and screen (7) from the sediment strainer top assembly (5) and discard in an approved manner.
6. Install a new gasket (6) and screen (7) in position on the sediment strainer top assembly (5).
7. Replace the bowl (3) under the sediment strainer top assembly (5).
8. Rotate the bale (4) downward and center under the bowl (3).

9. Tighten knurled nut (2) at base of sediment strainer bowl (3).

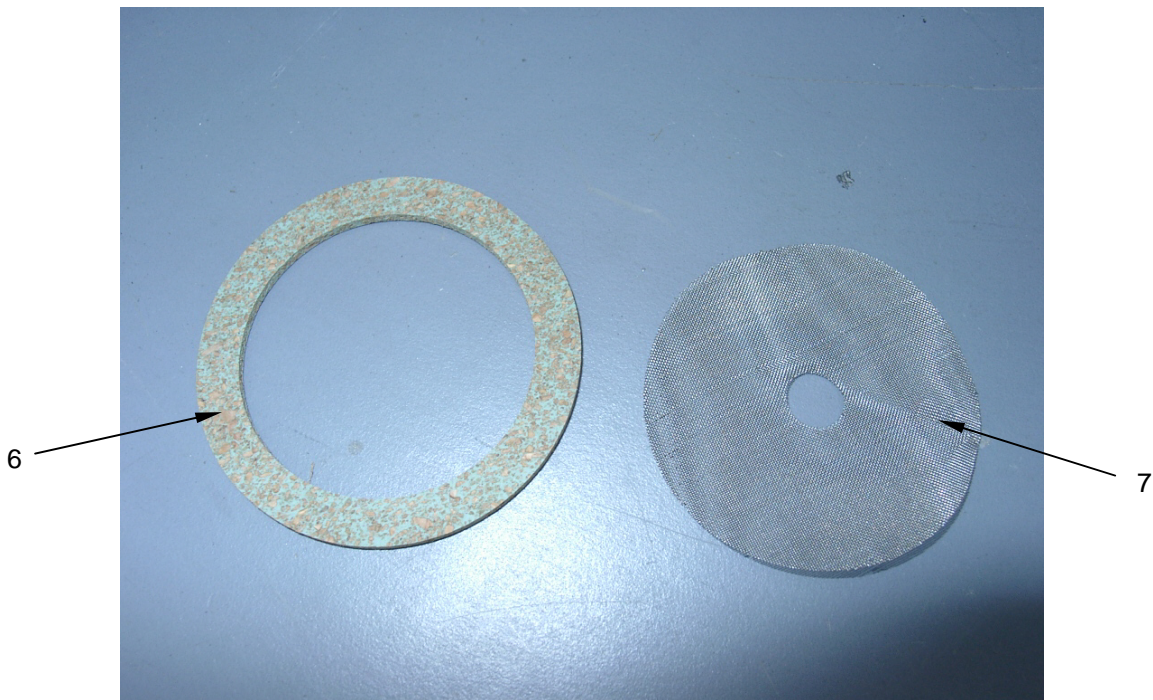
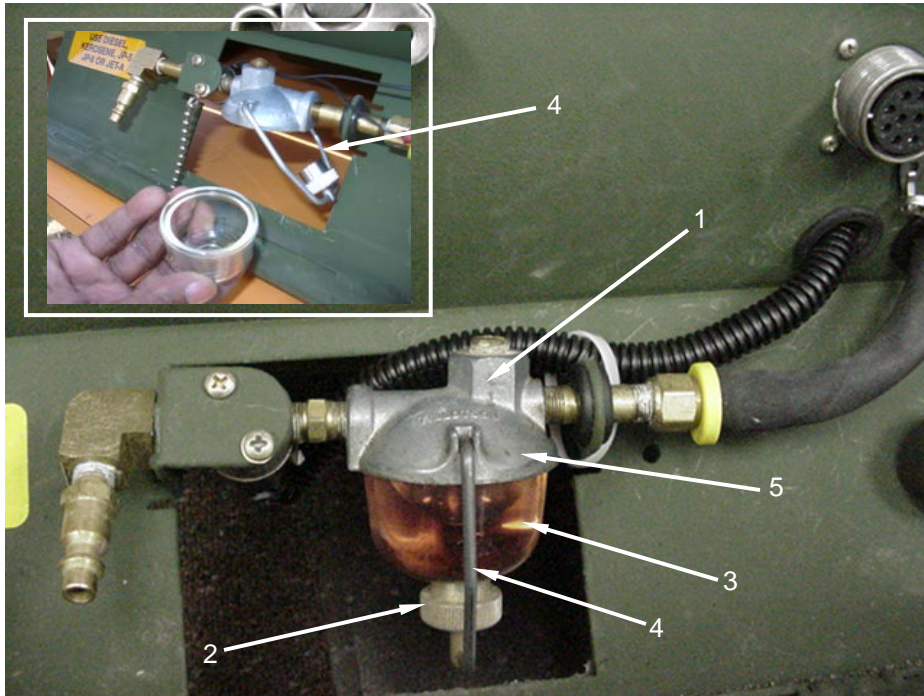

REPLACE**CAUTION**

Thread sealant is used to seal the threads on the various fittings of the fuel solenoid and sediment strainer assembly. Once the sealant has set, it may require some force to break the sealant's bond. However, take care not to apply excessive force which could result in damage to the components.

1. Before removing the fuel solenoid valve and sediment strainer assembly **(1)**, drain the sediment strainer **(2)** of fuel by loosening the knurled nut **(3)** at the base of the sediment strainer bowl **(4)**.
2. Rotate the bale **(5)** upward while supporting the bowl **(4)**.
3. Rock the bowl **(4)** slightly and remove it from the sediment strainer top assembly **(6)**.
4. Empty the fuel from the bowl **(4)** into an approved container and discard. Do not empty the fuel into a fresh fuel supply. Replace the bowl **(4)**, rotate the bale **(5)** downward and center under the bowl. Tighten the knurled nut **(3)** taking care not to over tighten.
5. Cut the tie wrap **(7)** securing the wire loom **(21)** that protects the fuel solenoid valve electrical connectors and wires **(8)** to the sediment strainer outlet fitting **(9)**. Remove the wire loom **(21)** by separating at the seam and lifting off the wires. Disconnect the fuel solenoid valve connectors **(8)**.
6. Remove the protective dust cap **(10)** from the fuel quick disconnect **(11)**.
7. Remove the fuel quick disconnect **(11)** as detailed in WP 0020 and set aside.
8. Using a wrench, remove the fuel quick disconnect elbow fitting **(12)** and set aside.
9. Wrap a rag around the end of the fuel hose **(13)** and grasp the end of the fuel hose near the fuel hose fitting **(14)** with a pair of pliers. Be sure that the rag is between the hose and the pliers so as to protect the hose from damage.
10. While holding the fuel hose **(13)** securely, use a wrench to loosen the fuel hose fitting **(14)**. Remove the fuel hose fitting **(14)** from the sediment strainer outlet fitting **(9)**. Have a petroleum absorbent mat or tray with absorbent material nearby to collect any fuel that may be in the fuel hose.
11. Remove the two screws **(15)** and protective dust cap **(10)** that secure the fuel solenoid valve **(16)** to the external fuel system bracket **(17)**.
12. While rotating the fuel solenoid valve and sediment strainer assembly **(1)** back and forth slightly toward and away from the heater, slide the assembly **(1)** to the right until the solenoid valve inlet fitting **(18)** clears the external fuel system bracket **(17)**.
13. Drop the left end of the assembly with the solenoid valve inlet fitting **(18)** down below the bracket **(17)** and slide the assembly **(1)** to the left while rotating slightly as described above. Continue until the assembly **(1)** clears the sediment strainer bracket **(19)** and rubber grommet **(20)** to the right of the sediment strainer.

NOTE

The protective rubber dust cap (10) was removed from the fuel quick disconnect (11) for illustrative purposes. The figure below shows that the fitting (18) is between elbow (12) and solenoid (16).

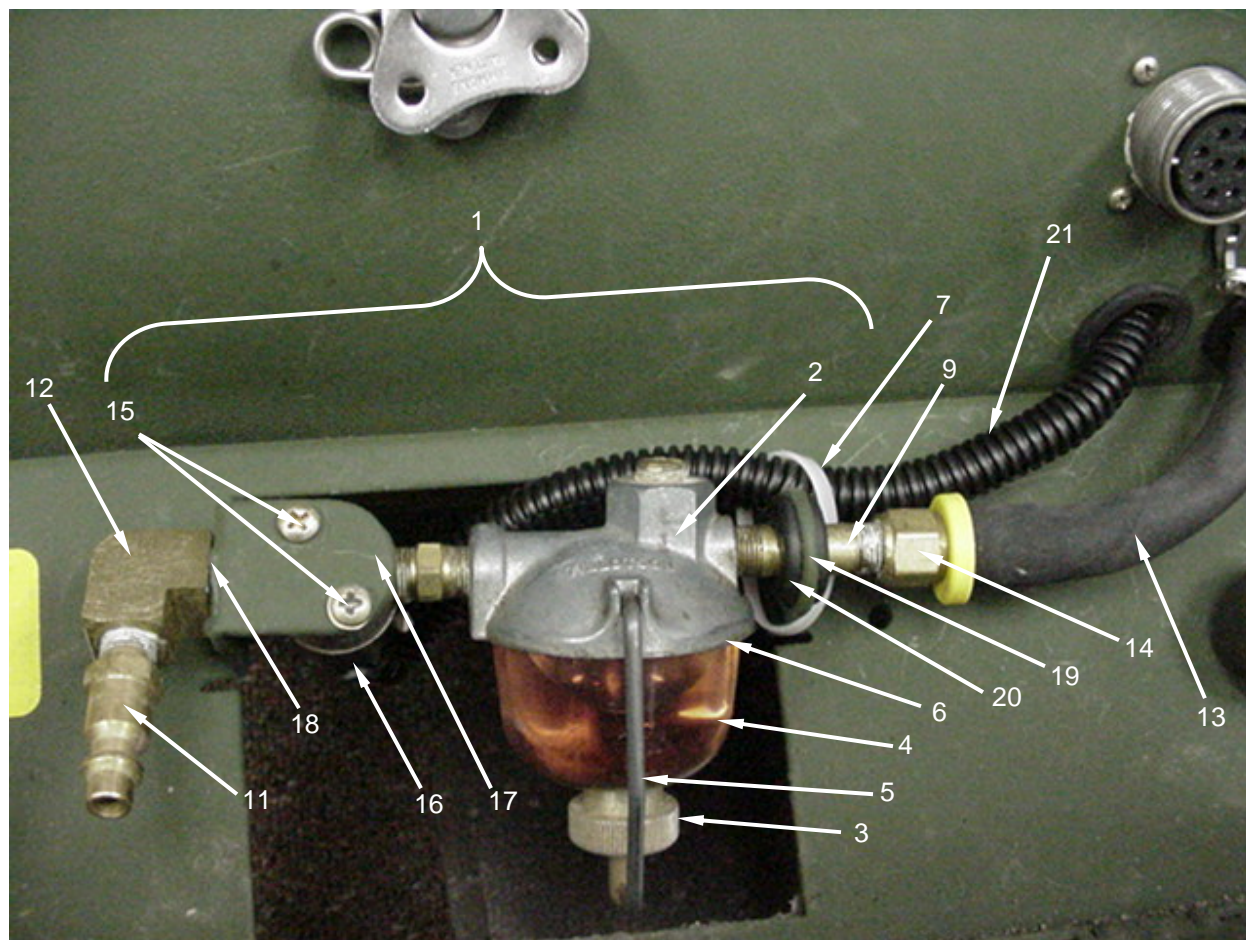
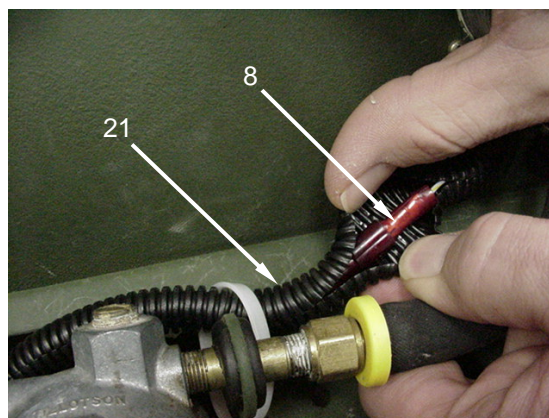
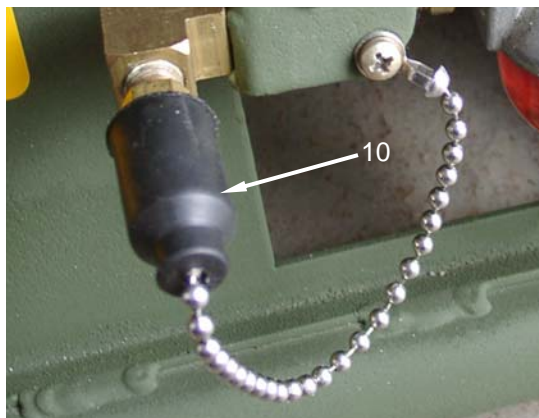

14. To install a new solenoid valve and sediment strainer assembly **(1)**, insert the sediment strainer outlet fitting **(9)** into the rubber grommet **(20)** on the sediment strainer bracket **(19)** closest the fuel hose **(13)**. Continue until the solenoid valve inlet fitting **(18)** has cleared the external fuel system bracket **(17)**.
15. Swing the left end of the assembly with the solenoid valve inlet fitting **(18)** under the external fuel system bracket **(17)** and insert the fuel solenoid inlet fitting **(18)** into the hole on the external fuel system bracket **(17)**.
16. Rotate the assembly **(1)** while sliding the assembly to the left until the holes on the top of the fuel solenoid valve **(16)** are aligned with the holes on the external fuel system bracket **(17)**.
17. Install the two screws **(15)** and protective dust cap **(10)** through the external fuel system bracket **(17)** and into the fuel solenoid valve **(16)**. Tighten securely.
18. Wrap a rag around the end of the fuel hose **(13)** and grasp the end of the fuel hose near the fuel hose fitting **(14)** with a pair of pliers. Be sure that the rag is between the hose and the pliers in order to protect the hose from damage.
19. While holding the fuel hose **(13)** securely, use a wrench to engage the fuel hose fitting **(14)** on the sediment strainer outlet fitting **(9)**. Make sure that the fittings **(9 and 14)** engage correctly and do not cross-thread. Tighten the fuel hose fitting **(14)** securely.
20. Clean any residual thread sealant from the threads of the fuel quick disconnect elbow fitting **(12)** that was removed and set aside earlier. Apply new thread sealant to the threads of the fuel solenoid inlet fitting **(18)**. Tighten the fuel quick disconnect elbow fitting **(12)** securely taking care to align the opening **(22)** on the elbow fitting **(12)** so that it faces outward.
21. Clean any residual thread sealant from threads of the fuel quick disconnect **(11)**.
22. Apply new thread sealant to the threads of the fuel quick disconnect **(11)**.
23. Install the fuel quick disconnect **(11)** into the fuel quick disconnect elbow fitting **(12)** and tighten securely.
24. Reconnect the fuel solenoid valve electrical connectors **(8)**. Install the wire loom **(21)** over the fuel solenoid wires and connectors **(8)**. Install a new tie wrap **(7)** over the wire loom **(21)** and bracket **(19)** to secure the wire loom to the sediment strainer outlet fitting **(9)**.

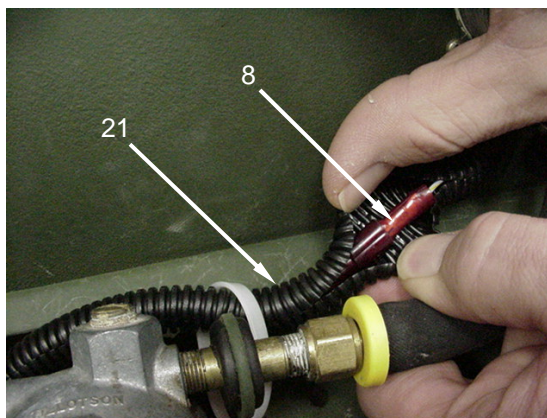
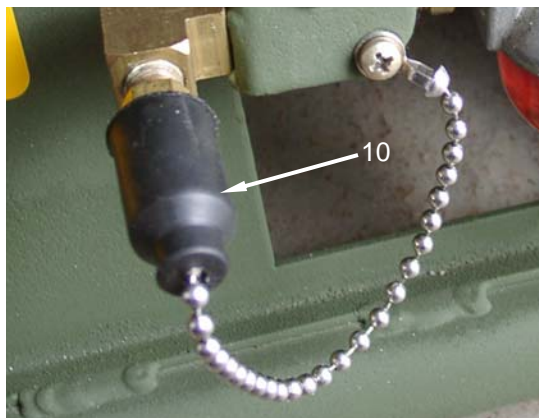

NOTE

The protective rubber dust cap (10) was removed from the fuel quick disconnect (11) for illustrative purposes. The figure below shows that the fitting (18) is between elbow (12) and solenoid (16).

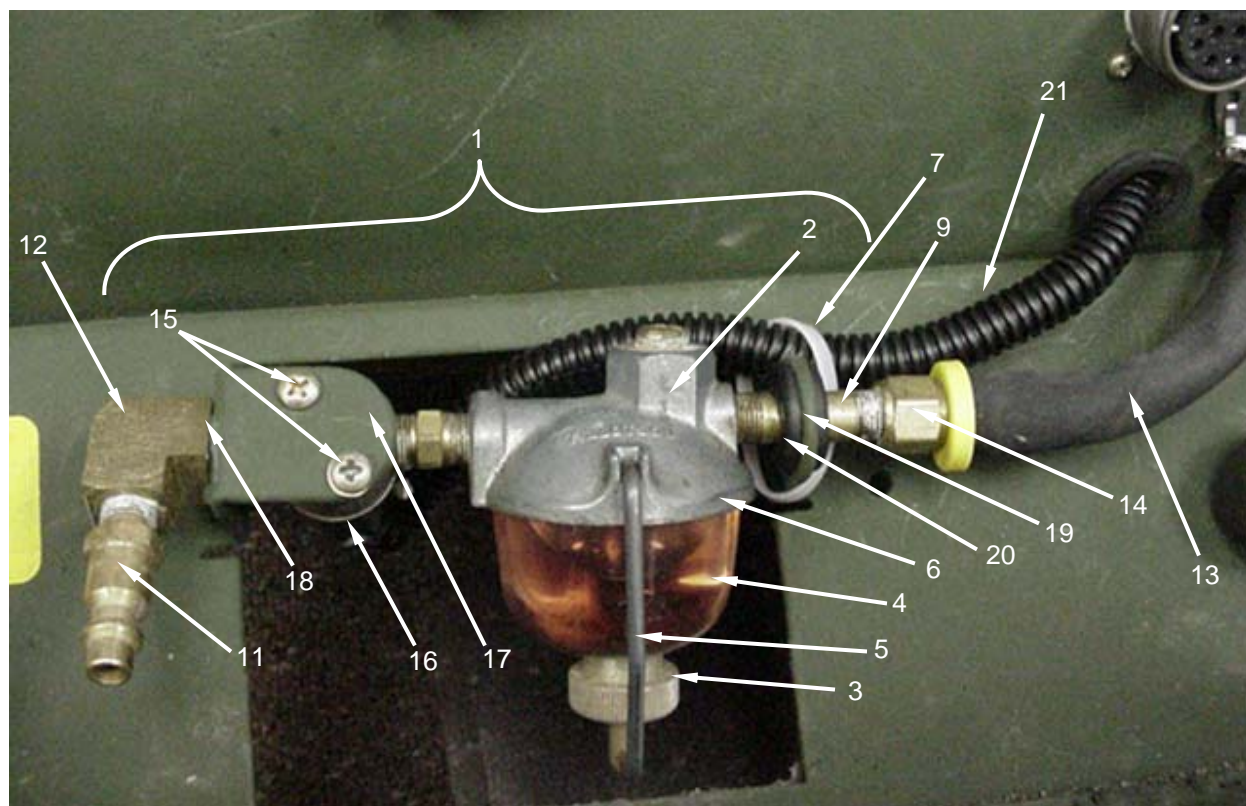



END OF WORK PACKAGE

UNIT MAINTENANCE
SPACE HEATER, CONVECTIVE

(NSN 4520-01-431-8927)

FUEL HOSE
INSPECT, REPLACE

INITIAL SETUPTools

Tool Kit, General Mechanics (WP 0044 00, Item 1)

Materials/Parts

Rags, Wiping, Clean (Item 5, WP 0067 00)
Mat, Petroleum Absorbent (Item 15, WP 0067 00)
Wrap, Tie (Item 16, WP 0067 00)

Personnel Required

One

Equipment Condition

Heater shut down and all advisory lights off. (WP 0006 00)
In-tent controller assembly disconnected from heater. (WP 0006 00)
Fuel supply disconnected. (WP 0006 00)
Sediment strainer bowl empty of fuel. (WP 0020 00)
Battery disconnected. (WP 0018 00)
Upper housing assembly removed. (WP 0030 00)

CAUTION

Disconnect battery connector. Before performing any maintenance actions, be sure to disconnect the battery to prevent component failure. Failure to comply may result in damage to electrical components.

INSPECT

1. Inspect the fuel hose **(1)** and fittings **(2)** for any cuts, abrasions, dents, or other damage that may cause the fuel hose to leak.
2. Inspect the rubber grommet **(3)** where the fuel hose passes through the side of the lower housing assembly for any damage that would prevent it from protecting the fuel hose from the sheet metal edges of the lower housing assembly.

REPLACE

1. To remove the fuel hose **(1)**, cut and remove the tie wraps **(4)** that secure the wire loom **(6)** to the sediment strainer outlet fitting **(7)** and the fuel hose **(1)**.
2. Move the wire loom **(6)** and enclosed wires out of the vicinity of the fuel hose **(1)**.

3. Wrap a rag around the end of the fuel hose **(1)** connected to the sediment strainer outlet fitting **(7)** and grasp the end of the fuel hose near the fuel hose fitting **(9)** with a pair of pliers. Be sure that the rag is between the hose and the pliers to protect the hose from damage.
4. Holding the fuel hose **(1)** securely, use a wrench to loosen the fuel hose fitting **(9)**. Remove the fuel hose fitting **(9)** from the sediment strainer outlet fitting **(7)**. Have a petroleum absorbent mat or tray with absorbent material nearby to collect any fuel that may be in the fuel hose.
5. Wrap a rag around the end of the fuel hose **(1)** which is connected to the float assembly inlet fitting **(10)** and grasp the end of the fuel hose near the fuel hose fitting **(11)** with a pair of pliers. Be sure that the rag is between the hose and the pliers to protect the hose from damage.
6. Holding the fuel hose **(1)** securely, use a wrench to loosen the fuel hose fitting **(11)**. Remove the fuel hose fitting **(11)** from the float assembly inlet fitting **(10)**. Place a small section of petroleum absorbent mat at the base of the lower heater housing to collect any residual fuel that may be in the fuel hose.
7. Pull the fuel hose and rubber grommet **(3)** out through the opening in lower housing assembly. Remove the grommet from the hose and re-install it back in the lower housing assembly opening.
8. Install a new fuel hose by inserting the end of the fuel hose with the fitting that installs to the sediment strainer assembly through the rubber grommet **(3)** from the inside of the heater, guiding it out of the lower heater housing. It may be easier to insert the fuel hose through the grommet by wetting the inside surface of the grommet. Move the fuel hose fitting **(11)** into position near the float assembly inlet fitting **(10)**.
9. Wrap a rag around the end of the fuel hose **(1)** which is to be connected to the float assembly inlet fitting **(10)** and grasp the end of the fuel hose near the fuel hose fitting **(11)** with a pair of pliers. Be sure that the rag is between the hose and the pliers to protect the hose from damage.
10. Holding the fuel hose **(1)** securely, use a wrench to tighten the fuel hose fitting **(11)** securely.
11. Wrap a rag around the end of the fuel hose **(1)** which is to be connected to the sediment strainer outlet fitting **(7)** and grasp the end of the fuel hose near the fuel hose fitting **(9)** with a pair of pliers. Be sure that the rag is between the hose and the pliers to protect the hose from damage.
12. Holding the fuel hose **(1)** securely, use a wrench to tighten the fuel hose fitting **(9)** onto the sediment strainer outlet fitting **(7)**.
13. Install a new tie wrap **(4)** in the same location as before and secure the wire loom **(6)** to the sediment strainer outlet fitting **(7)** and the fuel hose **(1)**.

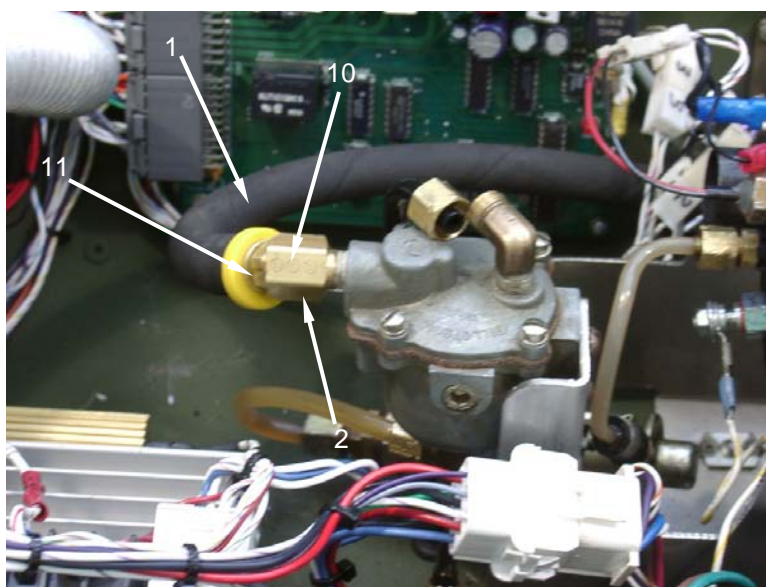
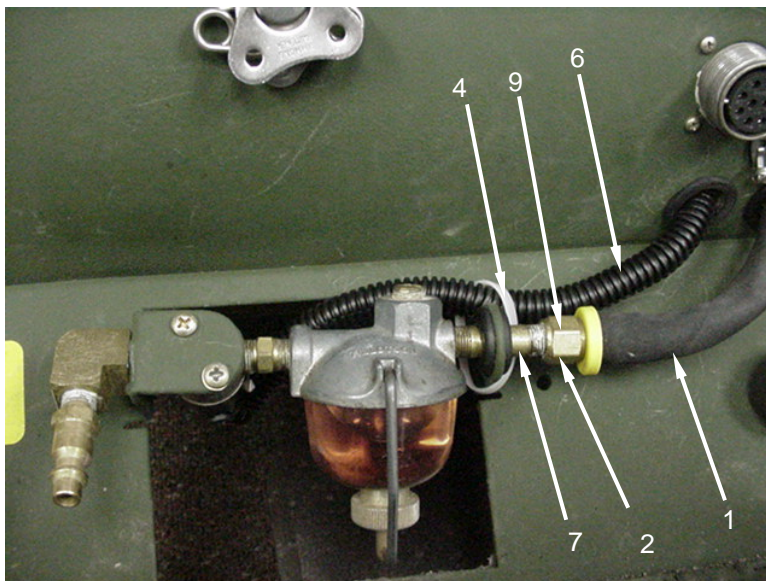

END OF WORK PACKAGE

UNIT MAINTENANCE
SPACE HEATER, CONVECTIVE
(NSN 4520-01-431-8927)
HEATER CONTROL ASSEMBLY
REPLACE

INITIAL SETUP**Tools**

Tool Kit, General Mechanics (Item 1, WP 0044 00)

Materials/Parts**Personnel Required**

One

Equipment Condition

Heater shut down and all advisory lights off. (WP 0006 00)
In-tent controller assembly disconnected from heater. (WP 0006 00)
Fuel supply disconnected. (WP 0006 00)
Battery disconnected. (WP 0018 00)
Upper housing cover removed. (WP 0030 00)

CAUTION

Disconnect battery connector. Before performing any maintenance actions, be sure to disconnect the battery to prevent component failure. Failure to comply may result in damage to electrical components.

REPLACE

1. To replace the heater control assembly **(1)**, remove the combustion air inlet cover **(2)** by rotating the two quarter turn screws **(3)** until they release. Put the cover **(2)** aside.
2. Remove the four screws **(4)** that secure the heater control assembly **(1)** to the side wall of the lower housing assembly **(5)**.
3. Lift the heater control assembly **(1)** partially out of the heater and remove the two connectors **(6 and 7)** on the left side of the heater control assembly by depressing the connector locks **(8)** and wiggling the connector back and forth while pulling outward.
4. Remove the heater control assembly from the lower housing assembly.
5. Install a new heater control assembly **(1)** by putting it into position on the lower housing assembly **(5)**.
6. Connect the two connectors **(6 and 7)** by engaging into the connectors on the heater control assembly **(1)** and pushing in until the connectors lock.

7. Install the four mounting screws (4) on the outside of the lower housing assembly (5) and secure.
8. Install the combustion air inlet cover (2) and secure by pushing in on the quarter turn screws (3) and rotating until they lock into position.

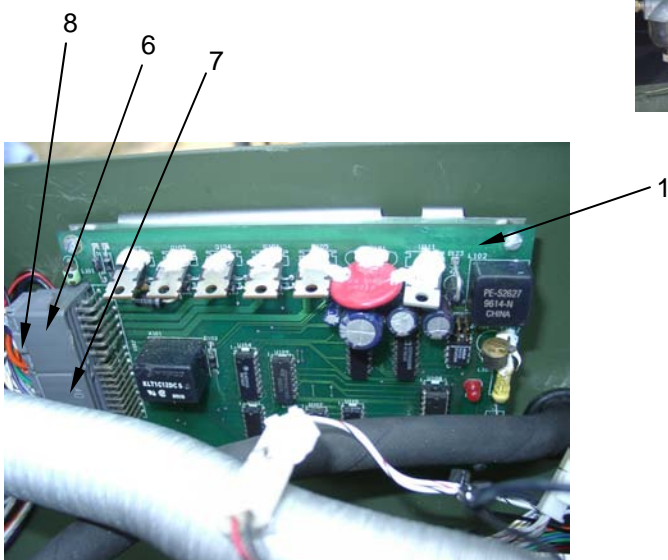
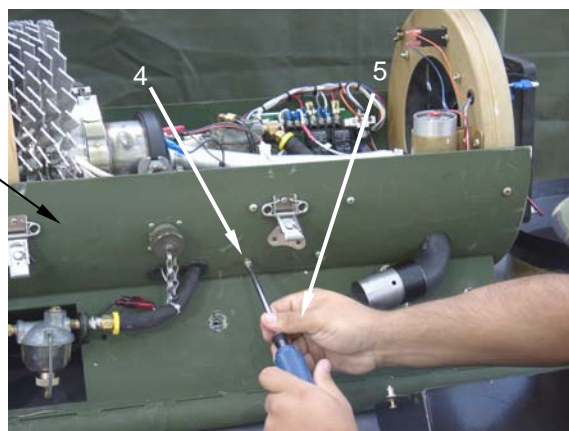
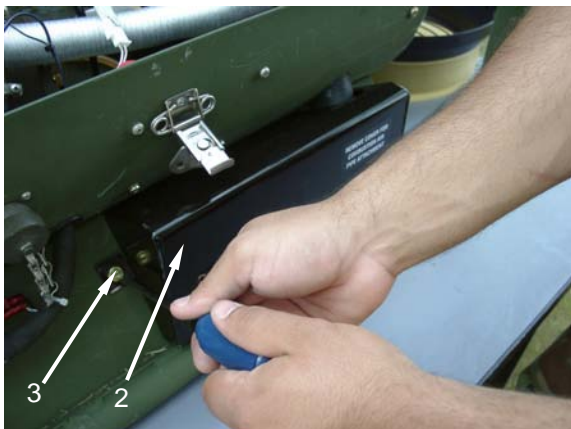

END OF WORK PACKAGE

UNIT MAINTENANCE**SPACE HEATER, CONVECTIVE****(NSN 4520-01-431-8927)****WIRE HARNESS****INSPECT, REPAIR, REPLACE****INITIAL SETUP****Tools**

Tool Kit, General Mechanics (Item 1, WP 0044 00)

Materials/Parts

Tape, Electrical (Item 7, WP 0067 00)

Wrap, Tie (Item 16, WP 0067 00)

Tags, Marking (Item 6, WP 0067 00)

Equipment Condition

Heater shut down and all advisory lights off. (WP 0006 00)

In-tent controller assembly disconnected from heater. (WP 0006 00)

Fuel supply disconnected. (WP 0006 00)

Battery disconnected. (WP 0018 00)

Upper housing assembly removed. (WP 0030 00)

CAUTION

Disconnect battery connector. Before performing any maintenance actions, be sure to disconnect the battery to prevent component failure. Failure to comply may result in damage to electrical components.

INSPECT

1. Inspect the connectors **(1)** on the wire harness to ensure that all connectors are securely mated and locked together.
2. Inspect the wire **(2)** for any cuts or abrasions to the insulation that would expose bare wire. Repair any breaks or abrasions as detailed below.
3. Inspect the tie wraps **(3)** and ensure that none are broken or cut. Replace any tie wraps that are damaged.

REPAIR

1. Repair any cuts or abrasions on the wires **(2)** with electrical tape, wrapping each repaired area with at least two layers of tape.
2. Repair tie wraps **(3)** by removing any broken pieces and installing a new tie wrap.

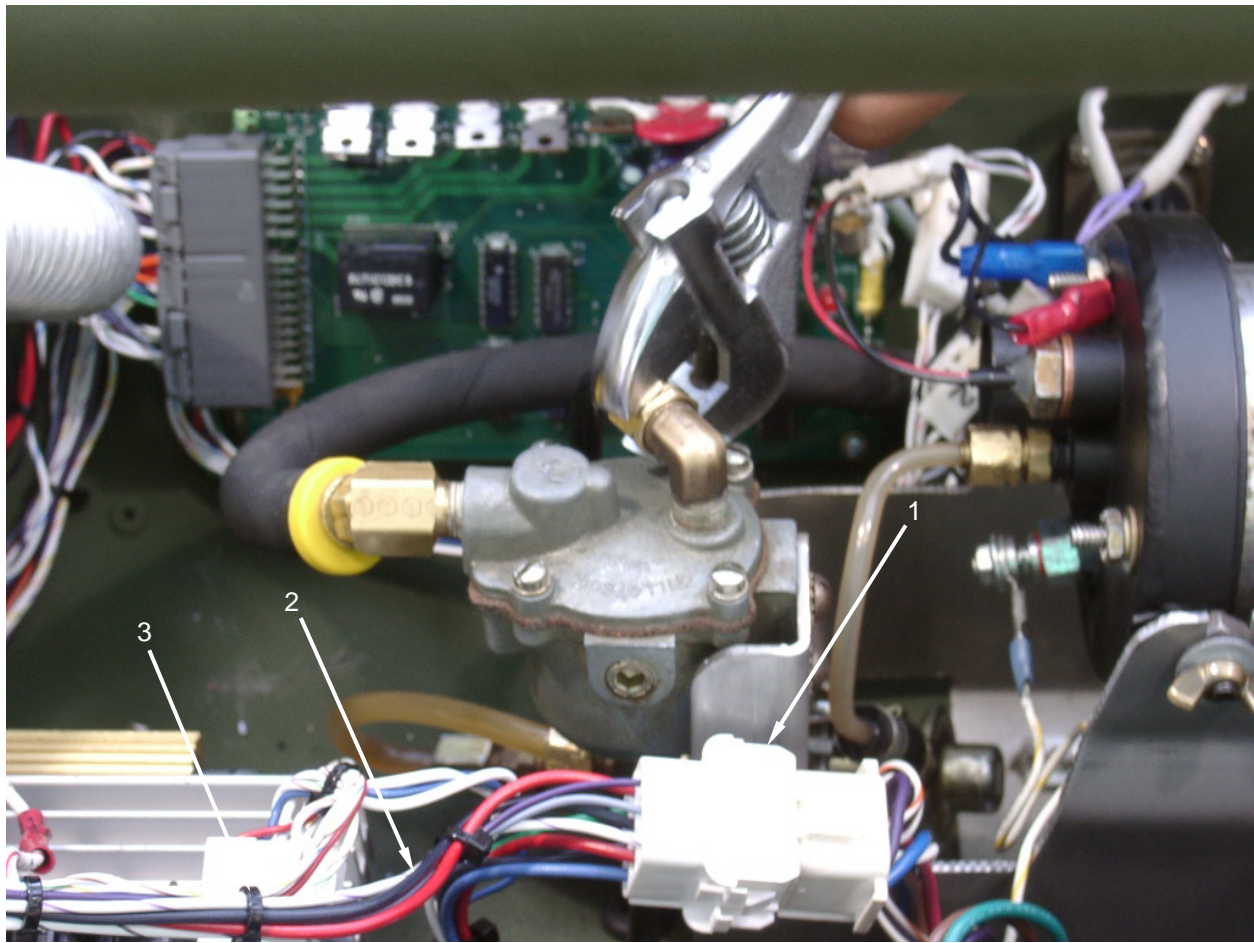

REPLACE**NOTE**

Before attempting to replace the wire harness, verify that the replacement harness is equipped with the same attaching hardware and components as the wire harness that is being replaced.

To aid in identification of wire connection points, tag the wire harness that is being replaced and retain as a reference in placement of new wire harness connection points.

1. Remove the wire harness from the SHC 35K as follows:
 - a. Unplug the 9-pin Ignition Pack connector **(1)** from the Ignition Pack Assembly **(2)**.
 - b. Pull the 9-pin Battery connector **(3)** out of the lower housing.
 - c. Unplug a 10-pin **(4)** and a 4-pin **(5)** connector from the Power Control Assembly.
 - d. Tag and disconnect the two power wires **(6)** from the TEG.

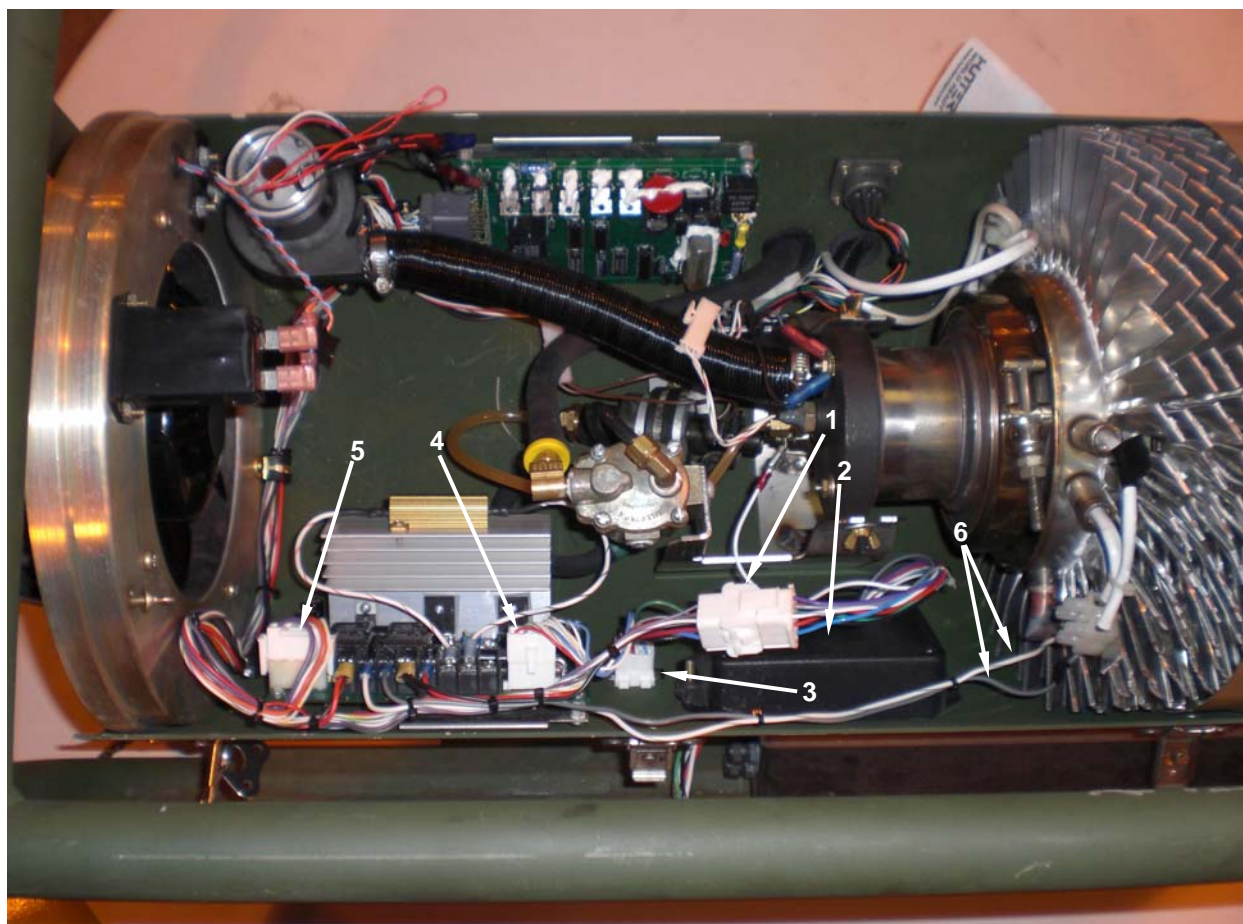

- e. Tag and disconnect five spade connectors **(1)** from the top of the Power Control Assembly.
- f. Unscrew and remove the loop clamp retaining screw and remove the loop clamp **(2)** from the vent fan housing. Remove the wires from the loop clamp **(2)** and set aside the loop clamp and retaining nut and screw.

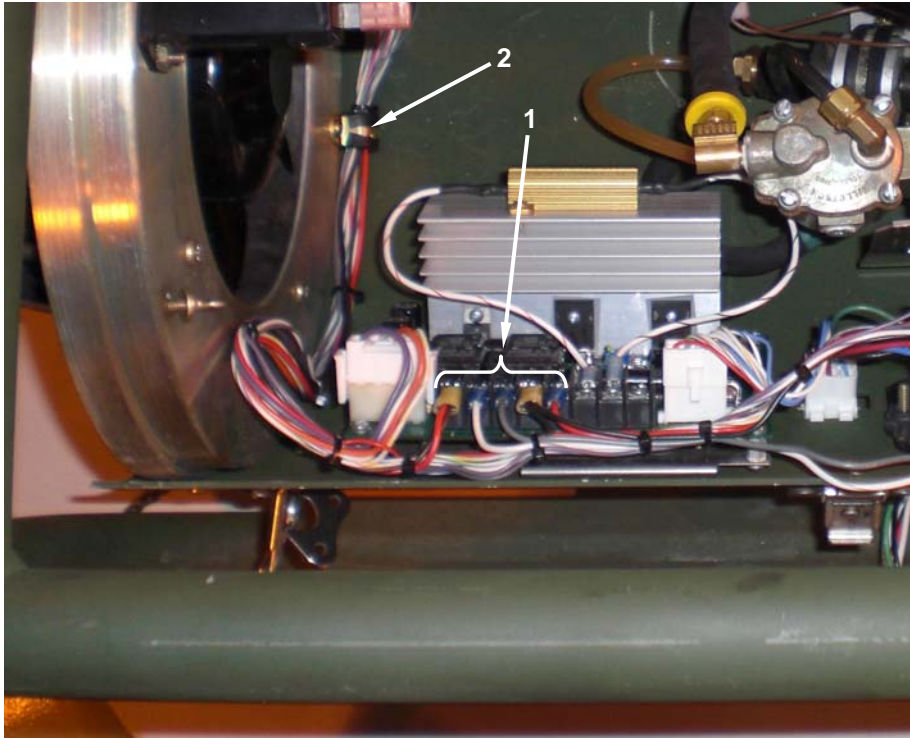

- g. If necessary to gain better access, remove the Combustion Blower end of the ducting hose **(1)** from the Combustion Blower.

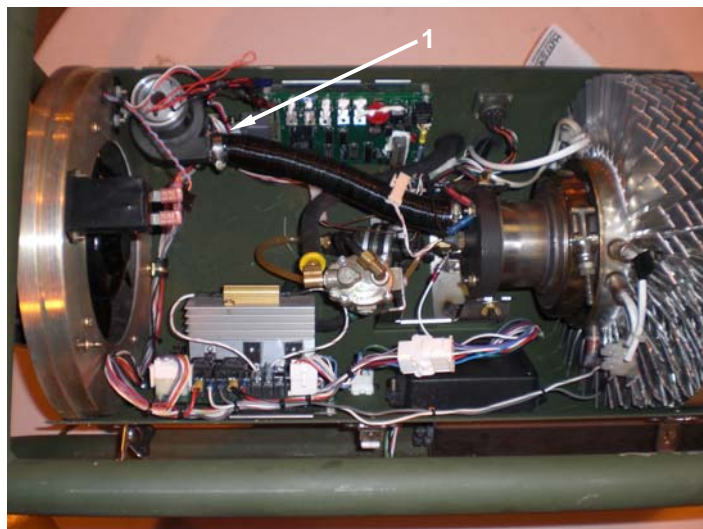

- h. Tag and remove the 12-pin **(1)** and 22-pin connectors **(2)** from the Heater Control Assembly.
- i. Tag and remove the two male/female QD wire connectors **(3)** from the Combustion Blower.

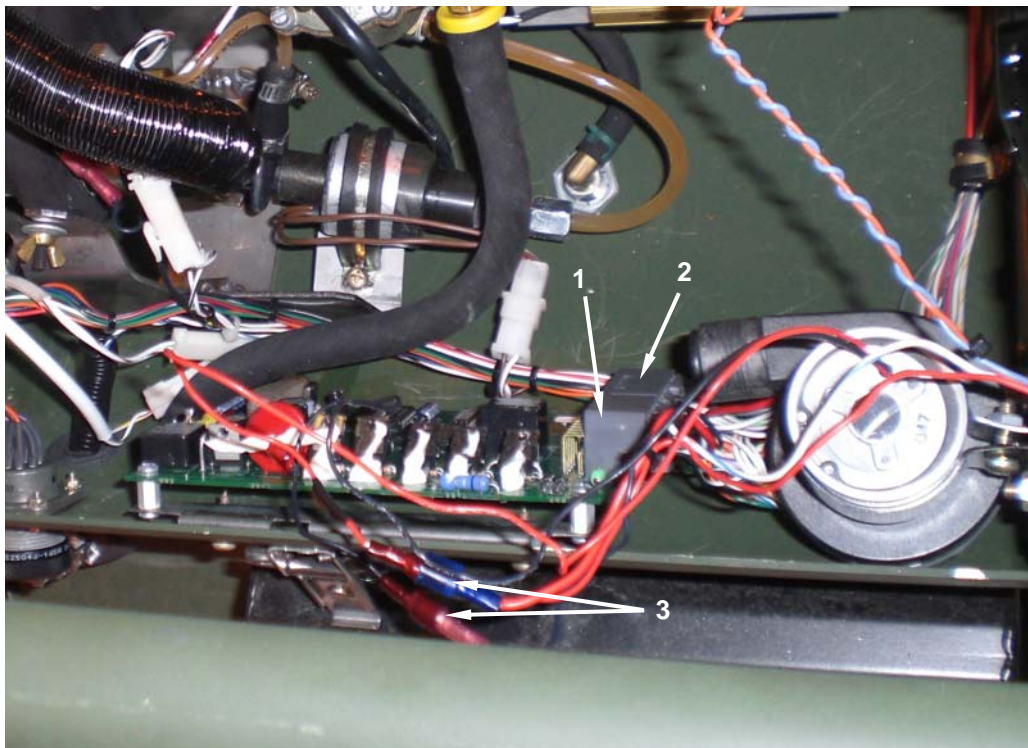

- j. Tag and remove the two male/female QD wire connectors **(1)** from the Vent Fan, located on the opposite side of the Vent Fan Housing. Remove and set aside the grommet **(2)**. Slide the wiring through the opening.

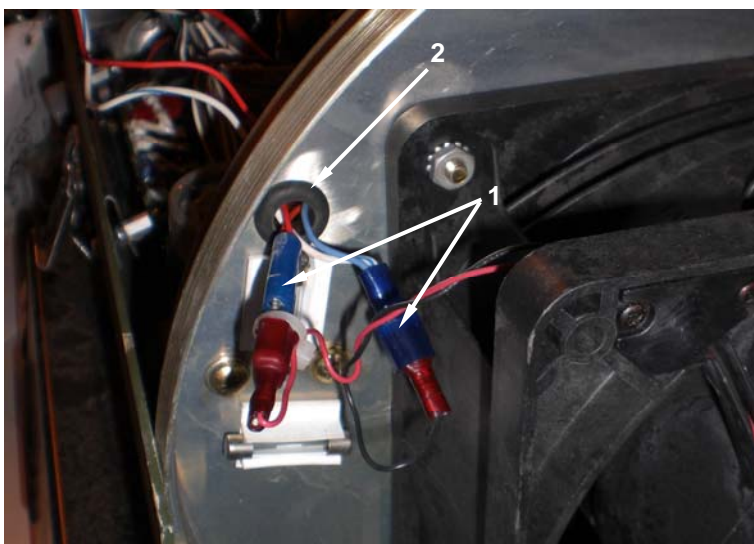

- k. Tag and remove the two female QD connectors **(1)** from the hour meter.
- l. Tag and remove the 2-pin **(2)** and 4-pin electrical connectors **(3)** from the TEG.

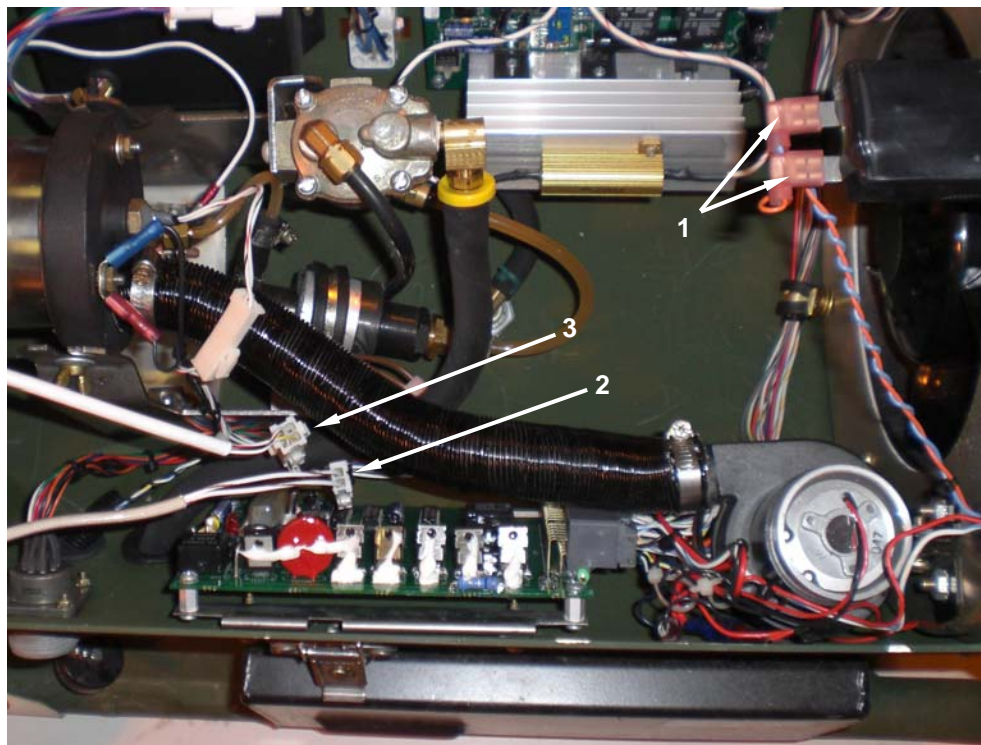

- m. Remove the In-Tent Controller connector **(1)** by removing four retaining screws, four lock-washers, and four nuts. Remove and set aside the gasket, protective dust cap with chain, screws, lock washers, and nuts for use with the replacement harness.

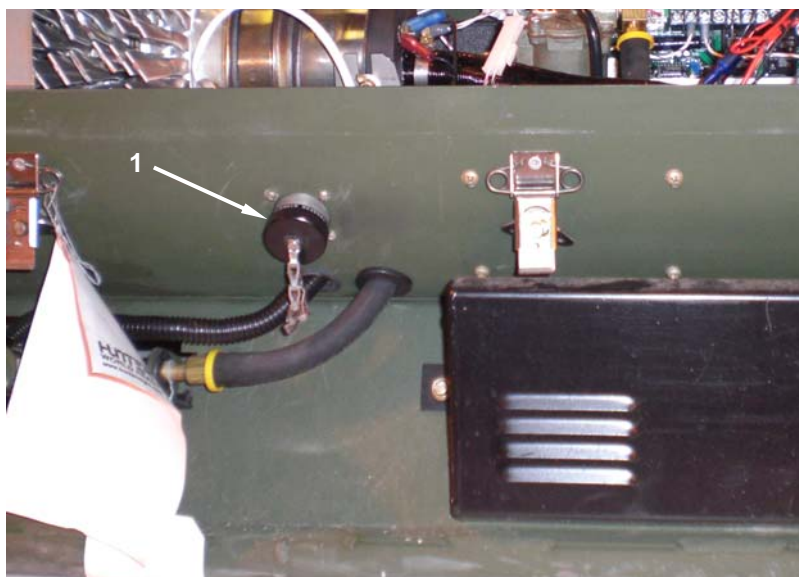

- n. Access the two Fuel Solenoid wires by removing the split wire loom. Tag and disconnect the two male/female QD connectors inside the wire loom. Remove the grommet and guide the wires back through the opening in the lower housing. Set aside the grommet and wire loom for use with the replacement harness.
- o. Tag and remove two ground wires **(1)** from the QD Twin Tab on the Burner Cover.
- p. Tag and remove 2-pin connector **(3)** from the flame sensor.
- q. Tag and remove 2-pin connector **(2)** from the Fuel Pump.

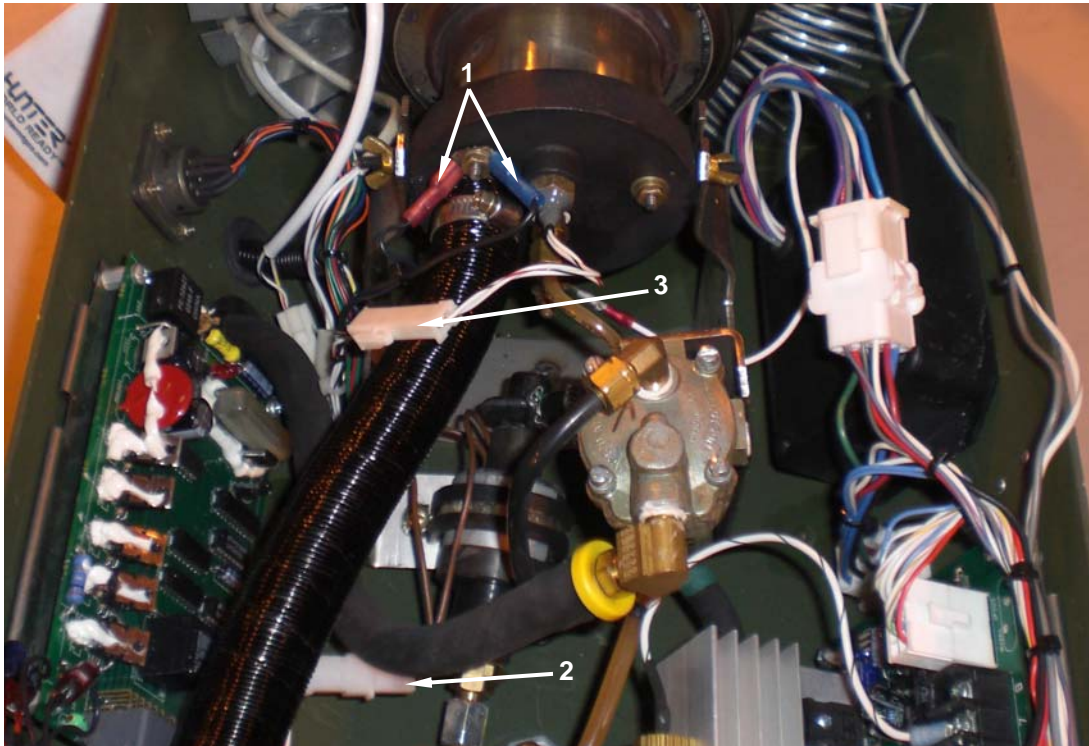

- 2. Remove the disconnected wire harness from the heater.
- 3. Position the replacement wire harness in the heater using the same orientation as the original wire harness.

4. Connect the replacement wire harness as follows:
 - a. Connect the 9-pin Ignition Pack connector **(1)** to the Ignition Pack Assembly **(2)**.
 - b. Route the 9-pin battery connector **(3)** through the opening in the lower housing.
 - c. Connect the 10-pin **(4)** and 4-pin connectors **(5)** to the Power Control Assembly.
 - d. Connect the TEG power wires **(6)** to the TEG.



- e. Connect five spade connectors (1) to the Power Control Assembly.

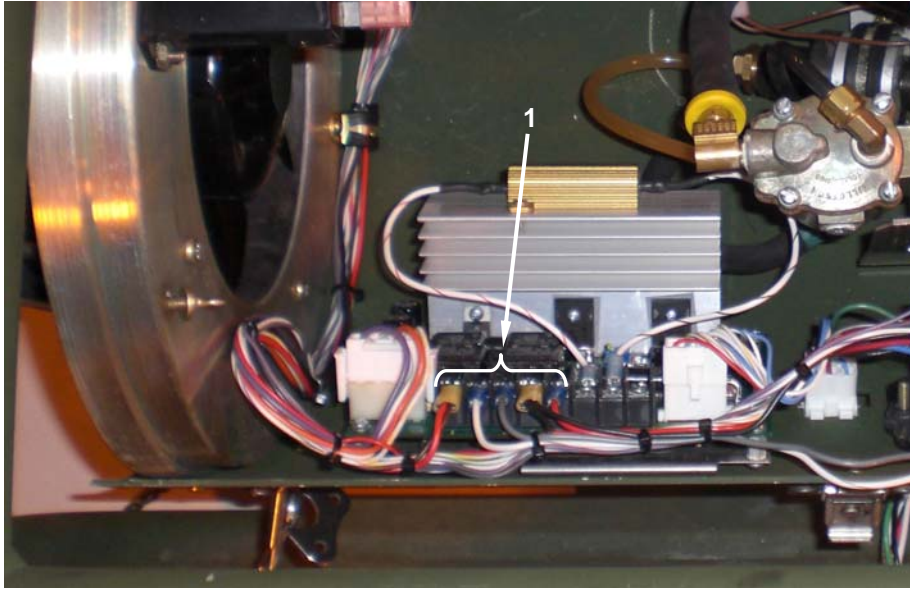

- f. Connect the 12-pin (1) and 22-pin (2) connectors to the Heater Control Assembly.

- g. Connect the two male/female QD wire connectors (3) to the Combustion Blower.

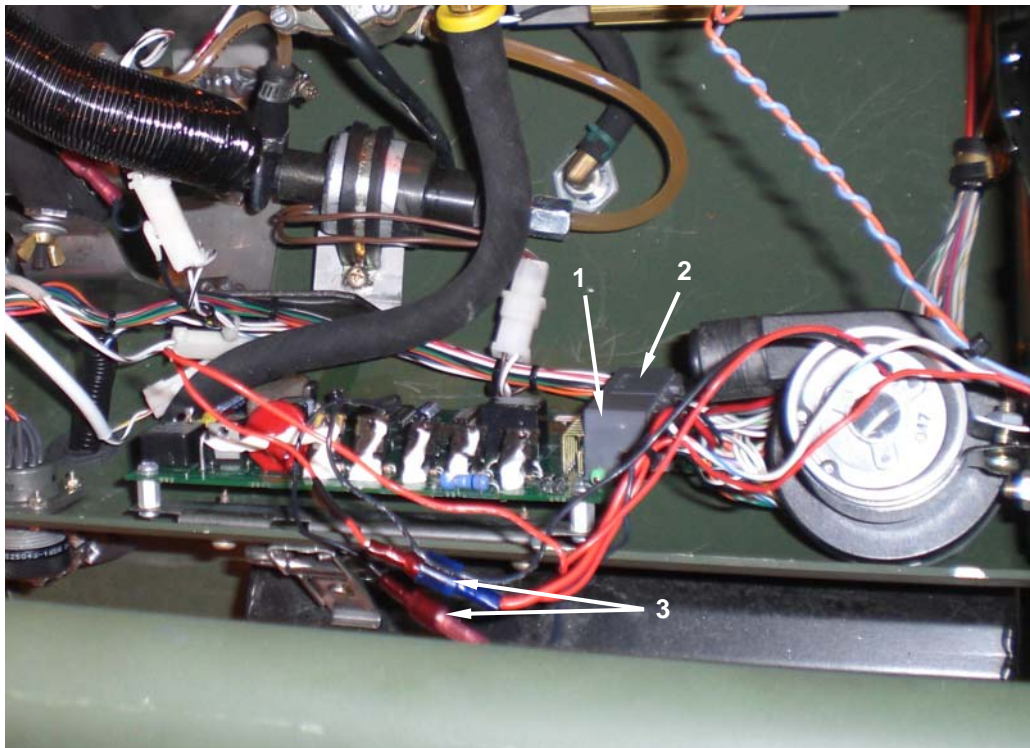

- h. Route the two Vent Fan wires (1) through the Vent Fan Housing grommet (2) previously set aside. Route the two Vent Fan wires through opening in the Vent Fan Housing and connect the wires to the Vent Fan. Seat the grommet in the Vent Fan Housing.

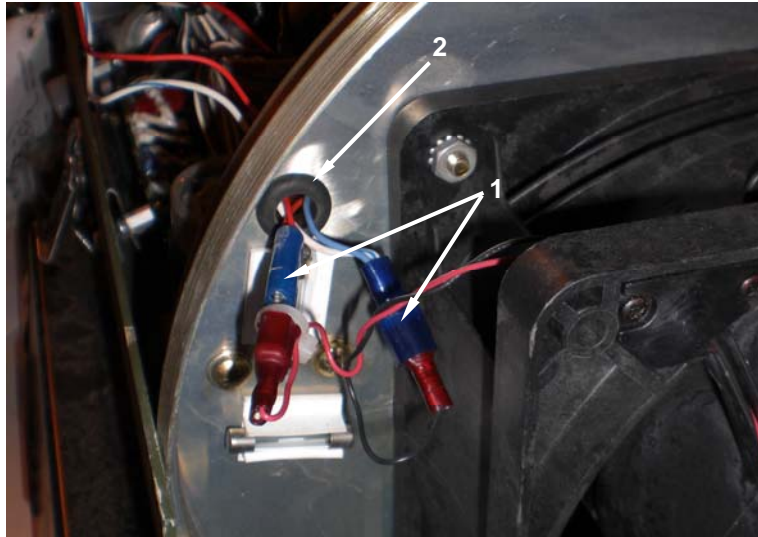

- i. Connect the two female QD connectors (1) to the Hour Meter.

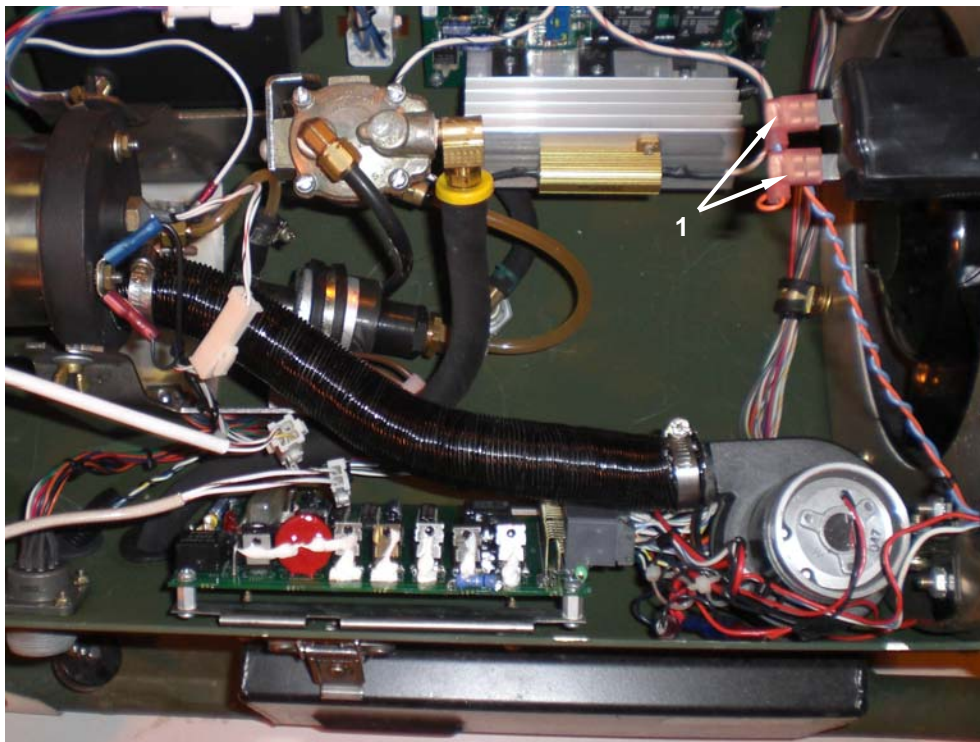

- j. Seat the other previously set aside grommet in the opening **(1)** in the lower housing. Route the two fuel solenoid wires through the opening **(1)** in the lower housing and connect the wires to the Fuel Solenoid. Cover the wires with the wire loom **(2)** previously set aside. Slide one end of the wire loom through the opening **(1)** in the lower housing ensuring that the wire loom covers the exposed wiring up to the Fuel Solenoid.
- k. Ensure In-Tent Controller Connector gasket is seated on the In-Tent Controller Connector **(3)**. Secure the In-Tent Controller Connector **(3)** to the lower housing using the four retaining screws, four washers, and four nuts. Secure the protective dust cap with chain by holding in place with the bottom left In-Tent Controller Connector retaining screw.

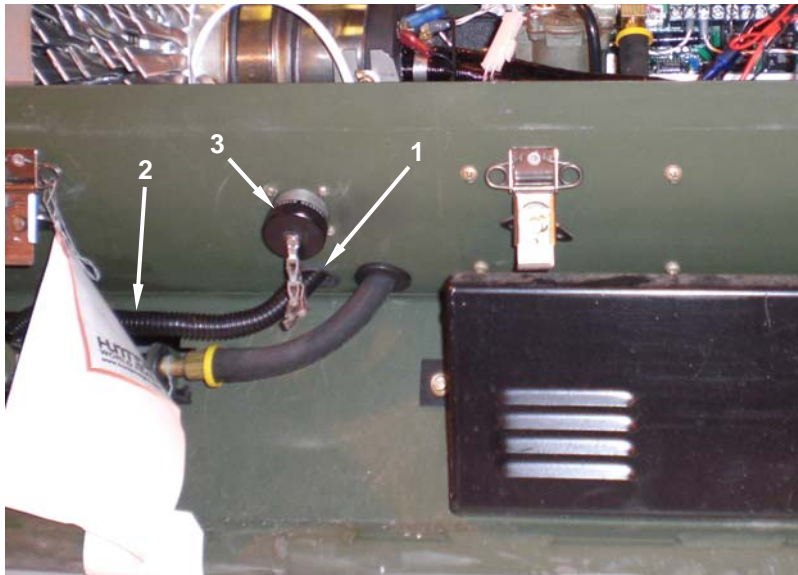

- I. Connect the 2-pin **(2)** and 4-pin **(1)** connectors to the TEG.

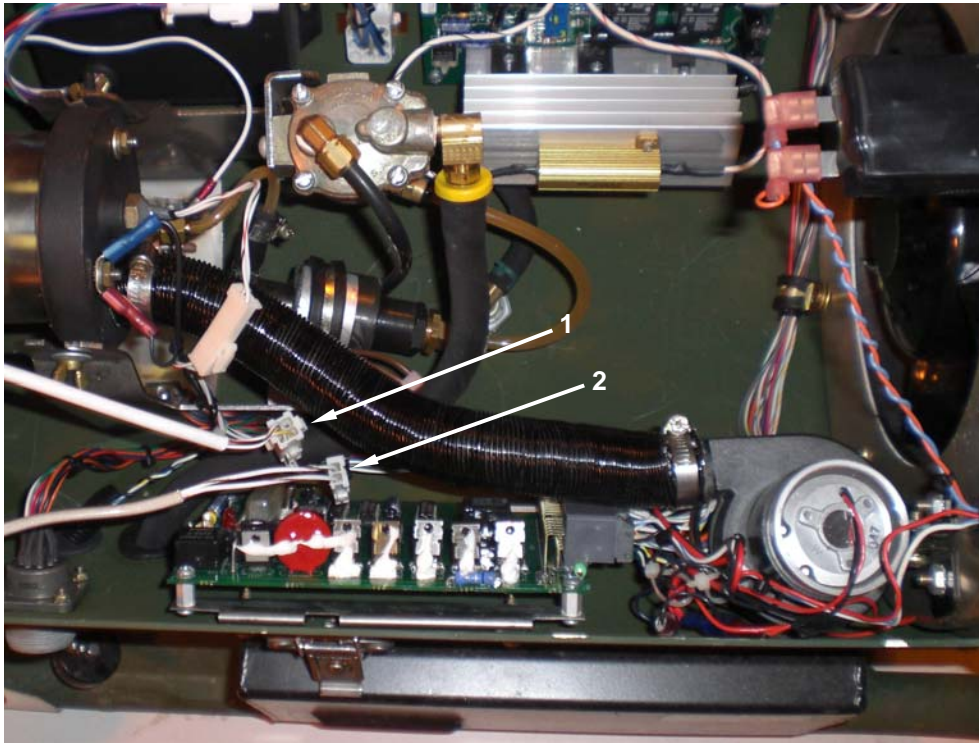

- m. Connect the 2-pin connector **(2)** to the fuel pump.
- n. Connect the two ground wires **(1)** to the QD Twin Tab on the Burner Cover.
- o. Connect the 2-pin connector **(3)** to the flame sensor.

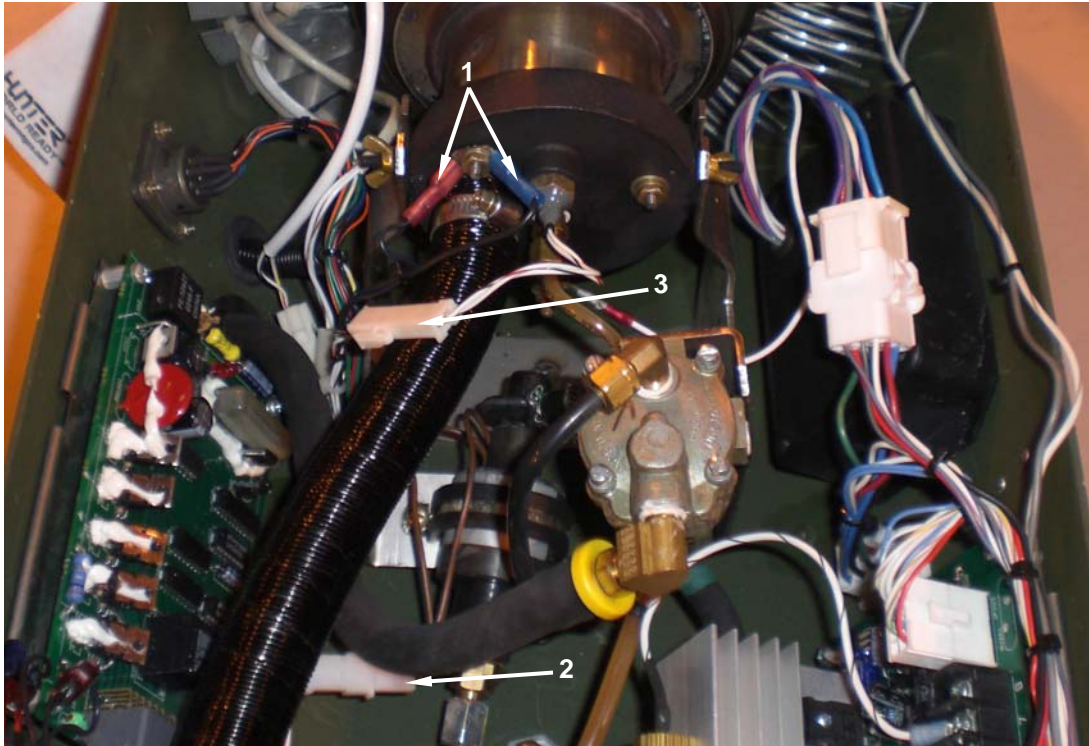

- p. Secure the wire harness to the bottom of the Vent Fan Housing with the previously set aside loop clamp.
 - q. If removed, reconnect the Combustion Blower ducting hose.
 - r. Secure any loose wires with tie wraps.
5. Replace the Upper Housing Assembly IAW WP 0030 00.

END OF WORK PACKAGE

UNIT MAINTENANCE
SPACE HEATER, CONVECTIVE
(NSN 4520-01-431-8927)
POWER CONTROL ASSEMBLY
REPLACE

INITIAL SETUP**Tools**

Tool Kit, General Mechanics (Item 1, WP 0044 00)

Materials/Parts

Tags, marking, MIL-T-12755 (Item 6, WP 0067 00)

Equipment Condition

Heater shut down and all advisory lights off. (WP 0006 00)

In-tent controller assembly disconnected from heater. (WP 0006 00)

Fuel supply disconnected. (WP 0006 00)

Battery disconnected. (WP 0018 00)

Upper housing assembly removed (WP 0030 00)

CAUTION

Disconnect battery connector. Before performing any maintenance actions, be sure to disconnect the battery to prevent component failure. Failure to comply may result in damage to electrical components.

REPLACE

1. To remove the power control assembly **(1)**, tag or mark the five wires **(2)** that are attached to the top edge of the power control assembly so that they match the numbers labeled on the heater control assembly printed circuit board.
2. Remove the two connectors **(3 and 4)** on the left and right side of the the power control assembly.
3. Loosen and remove each of the five wires **(2)** from the top edge of the power board assembly.
4. Remove the screws **(5)** that secure the power control assembly **(1)** to the lower housing assembly **(6)**.
5. Remove the power control assembly **(1)** from the heater housing.

6. Install a new power control assembly (1) by putting it into position on the lower housing assembly (6).
7. Install the four mounting screws (5) and secure.
8. Install the five wires (2) with spade lugs to their original position along the top edge of the power control assembly. Be sure that the number marked on each wire matches the number labeled on the heater control assembly board.
9. Install the two connectors (3 and 4) on the left and right side of the power control assembly (1).

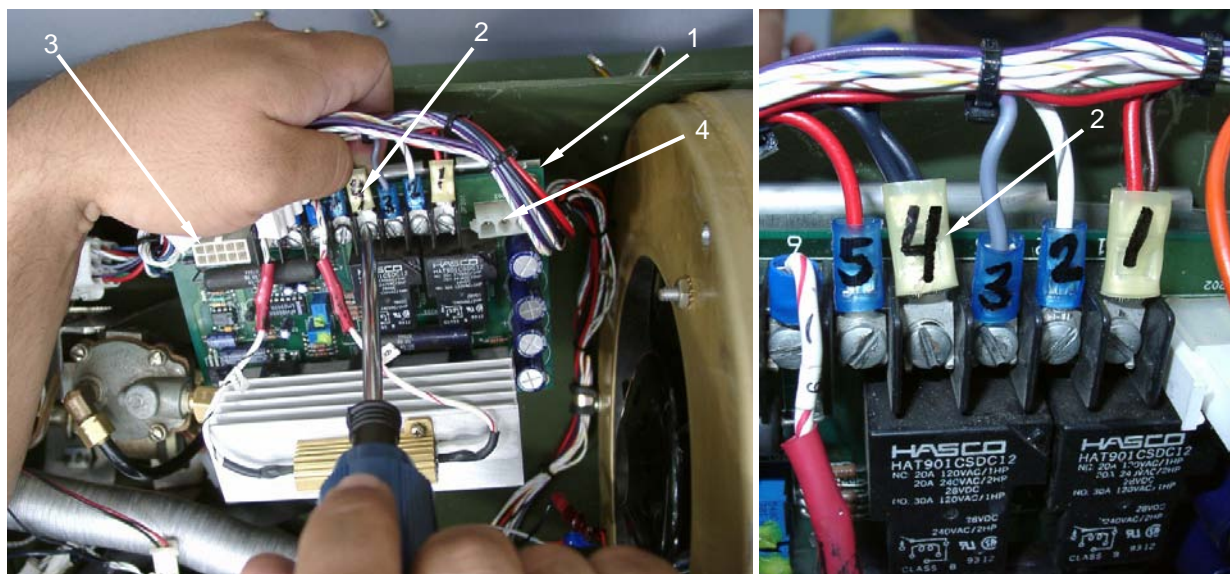

END OF WORK PACKAGE

UNIT MAINTENANCE
SPACE HEATER, CONVECTIVE
(NSN 4520-01-431-8927)
IGNITION PACK ASSEMBLY
REPLACE

INITIAL SETUP**Tools**

Tool Kit., General Mechanics (Item 1, WP 0044 00)

Materials/Parts**Equipment Condition**

Heater shut down and all advisory lights off. (WP 0006 00)

In-tent controller assembly disconnected from heater. (WP 0006 00)

Fuel supply disconnected. (WP 0006 00)

Battery disconnected. (WP 0018 00)

Upper housing assembly removed (WP 0030 00)

CAUTION

Disconnect battery connector. Before performing any maintenance actions, be sure to disconnect the battery to prevent component failure. Failure to comply may result in damage to electrical components.

REPLACE

1. To remove the ignition pack assembly **(1)**, separate the two halves of the connector **(2)** exiting the top of the ignition pack assembly.
2. Remove the wire **(3)** connecting the ignition pack **(1)** to the glow plug **(4)**.
3. Remove the two screws **(5)** that secure the ignition pack assembly to the lower housing assembly **(6)**.
4. Remove the ignition pack assembly **(1)** from the heater.
5. Install a new ignition pack assembly **(1)** by placing it in position on the lower housing assembly **(6)**.
6. Install the two screws **(5)** and secure.
7. Mate and secure the two halves of the connector **(2)** going to the top of the ignition pack assembly **(1)**.

8. Connect the wire (3) connecting the ignition pack (1) to the glow plug (4).

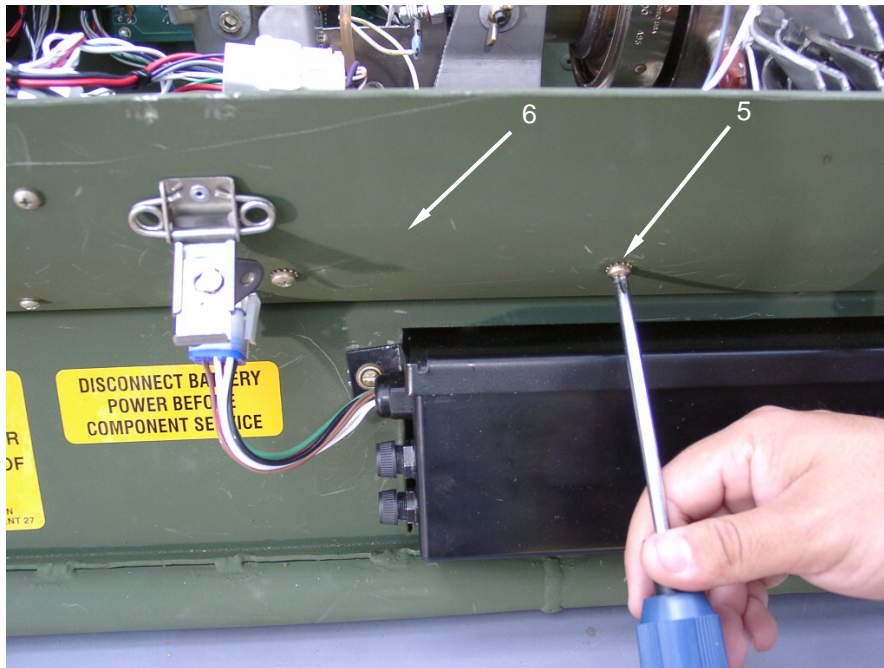
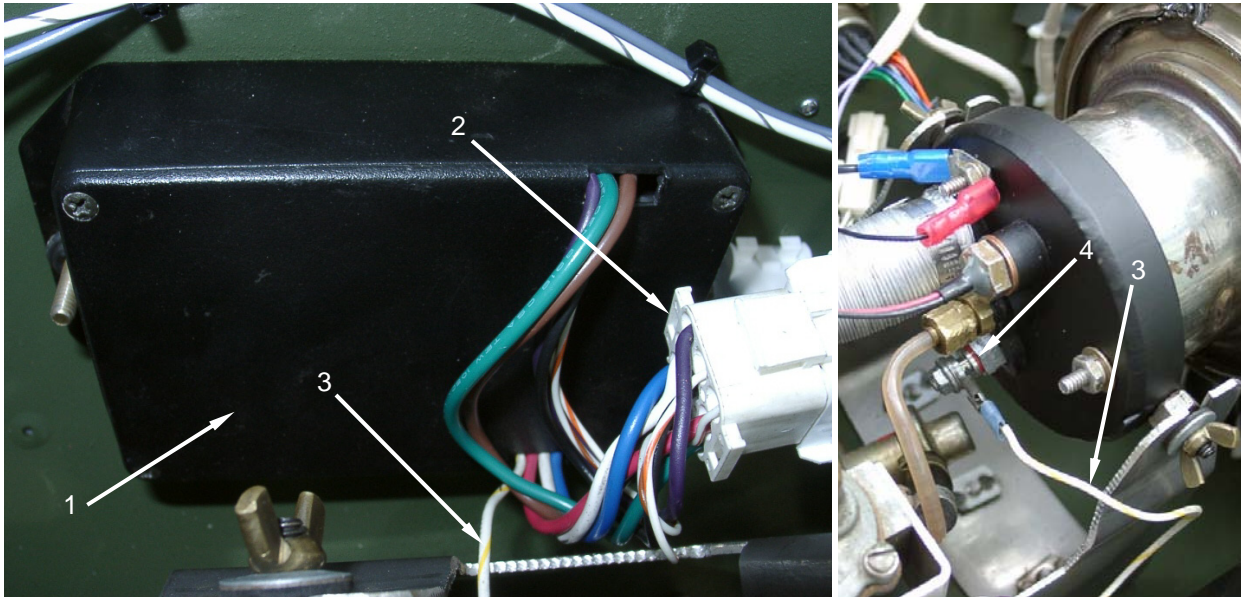

END OF WORK PACKAGE

UNIT MAINTENANCE**SPACE HEATER, CONVECTIVE****(NSN 4520-01-431-8927)****DUST COVER ASSEMBLY
INSPECT, REPLACE**

INITIAL SETUP**Tools**

Tool Kit, General Mechanics (Item 1, WP 0044 00)

Materials/Parts

Alcohol (Item 2, WP 0067 00)

Rags (Item 5, WP 0067 00)

Equipment ConditionHeater shut down and all advisory lights off. (WP 0006 00)



WARNING

Only clean parts in a well-ventilated area. Avoid inhalation of alcohol fumes or prolonged contact with skin. If contact with eyes is made, immediately flush with clean water and get medical first aid. Failure to comply may result in injury to personnel.

INSPECT

1. Inspect the dust cover **(1)** for any dents, cracks, cuts, or other damage that would prevent the dust cover from covering the duct adapter and properly protecting the heater from dust, sand, or other foreign matter.
2. Inspect the chain **(2)** for any cuts or breaks that would prevent it from securing the dust cover to the lower housing of the heater.
3. Wipe dust cover **(1)** thoroughly with a clean, dry rag. For oily or stubborn dirt, moisten rag with alcohol.

REPLACE

1. Pull dust cover **(1)** off duct adapter **(3)**.
2. Remove screw **(4)**, lock washer **(5)**, flat washer **(6)**, nut **(7)**, chain **(2)**, and dust cover **(1)**. Discard damaged dust cover.
3. Position chain over hole in lower housing and install screw **(4)**, lock washer **(5)**, flat washer **(6)**, and nut **(7)**.
4. Install dust cover **(1)** on duct adapter **(2)**.

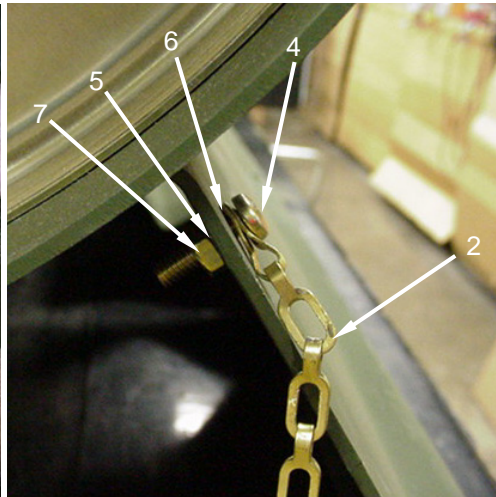
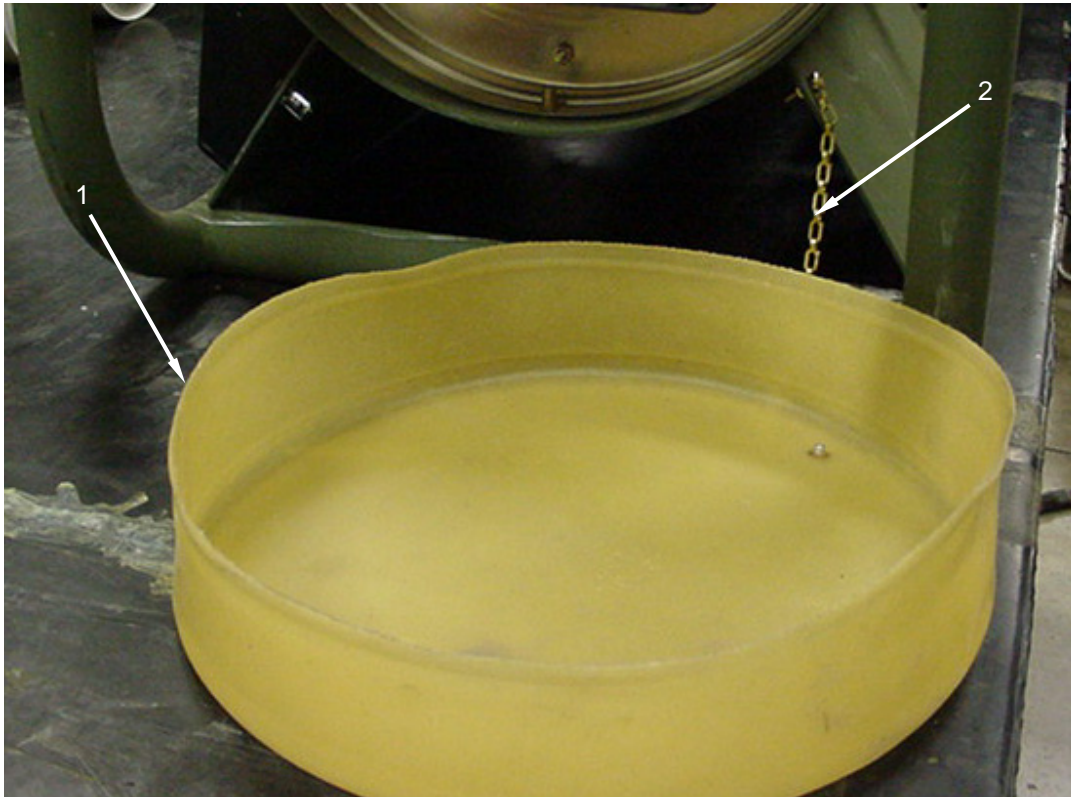

END OF WORK PACKAGE

UNIT MAINTENANCE
SPACE HEATER, CONVECTIVE
(NSN 4520-01-431-8927)
COMBUSTION AIR BLOWER ASSEMBLY
REPLACE

INITIAL SETUP**Tools**

Tool Kit, General Mechanics (Item 1, WP 0044 00)

Materials/Parts**Equipment Condition**

Heater shut down and all advisory lights off. (WP 0006 00)

Fuel supply disconnected. (WP 0006 00)

Battery disconnected. (WP 0018 00)

Upper housing assembly removed (WP 0023 00)

CAUTION

Disconnect battery connector. Before performing any maintenance actions, be sure to disconnect the battery to prevent component failure. Failure to comply may result in damage to electrical components.

REPLACE

1. Remove the combustion air inlet cover **(1)** by releasing the two quarter turn screws at either end of the cover. Remove the cover **(1)** and set aside.
2. Remove the two screws **(2)** that secure the combustion air inlet end fitting bracket **(3)** to the lower housing assembly. Set the bracket aside.
3. Remove the combustion air inlet end fitting **(4)** from the combustion air inlet hose **(5)** and set aside.
4. Remove the two screws and lockwashers **(13)** that secure the combustion air blower assembly **(8)** to the heated air blower housing **(14)**.
5. Remove the screw **(6)** that secures the blower assembly clamp **(7)** around the body of the combustion air blower assembly **(8)**.
6. Disconnect the combustion air blower assembly duct **(9)** from the combustion air blower outlet **(10)** by loosening the hose clamp **(11)** and pulling the duct **(9)** from the combustion air blower outlet **(10)**.

7. Disconnect the two combustion air blower electrical connectors **(12)**.
8. Carefully lift the combustion air blower assembly **(8)** from the heater guiding the combustion air inlet hose **(5)** through the side wall of the lower housing.
9. Remove the blower assembly clamp **(7)** and set aside.
10. Disconnect the combustion air blower assembly **(8)** from the combustion air inlet hose **(5)** by loosening the hose clamp **(15)**.
11. Install a new combustion air blower assembly **(8)** by installing the combustion air inlet hose **(5)** on the intake **(16)** of the combustion air blower assembly. Tighten hose clamp **(11)** securely.
12. Install the blower assembly clamp **(7)** on the body of the combustion air blower assembly **(8)**.
13. Lower the combustion blower assembly **(8)** into the lower housing, guiding the combustion air inlet hose **(5)** through the hole **(17)** in the side wall of the lower housing.
14. Connect electrical connectors **(12)**.
15. Tighten the screw **(6)** that secures the clamp **(7)** to the body of the combustion air blower assembly.
16. Tighten the screws **(2)** that secures the clamp **(7)** to the heated air blower assembly **(8)**.
17. Install the combustion air blower duct **(9)** onto the outlet **(10)** of the combustion air blower assembly. Be sure that the rubber sleeve in the duct is installed on the outlet before installing the blower duct. Tighten the hose clamp **(11)** securely.
18. Install the combustion air inlet end fitting **(4)** on the end of the combustion air inlet hose **(5)**.
19. Install the combustion air inlet bracket **(3)**. Secure with two screws **(2)**.
20. Install the combustion air inlet cover **(1)**. Secure the two, quarter turn screws.

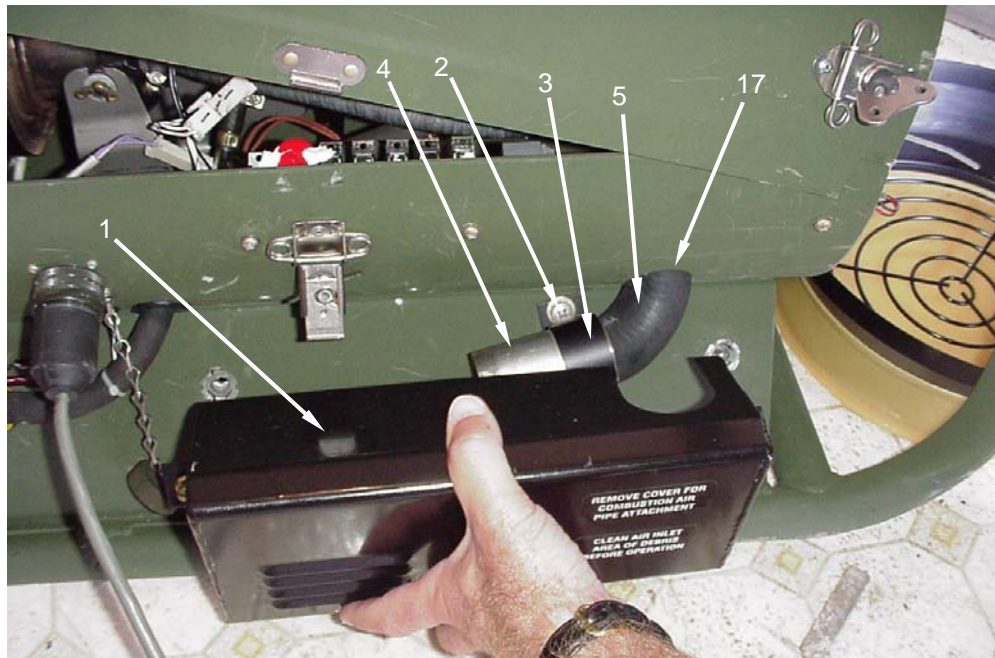

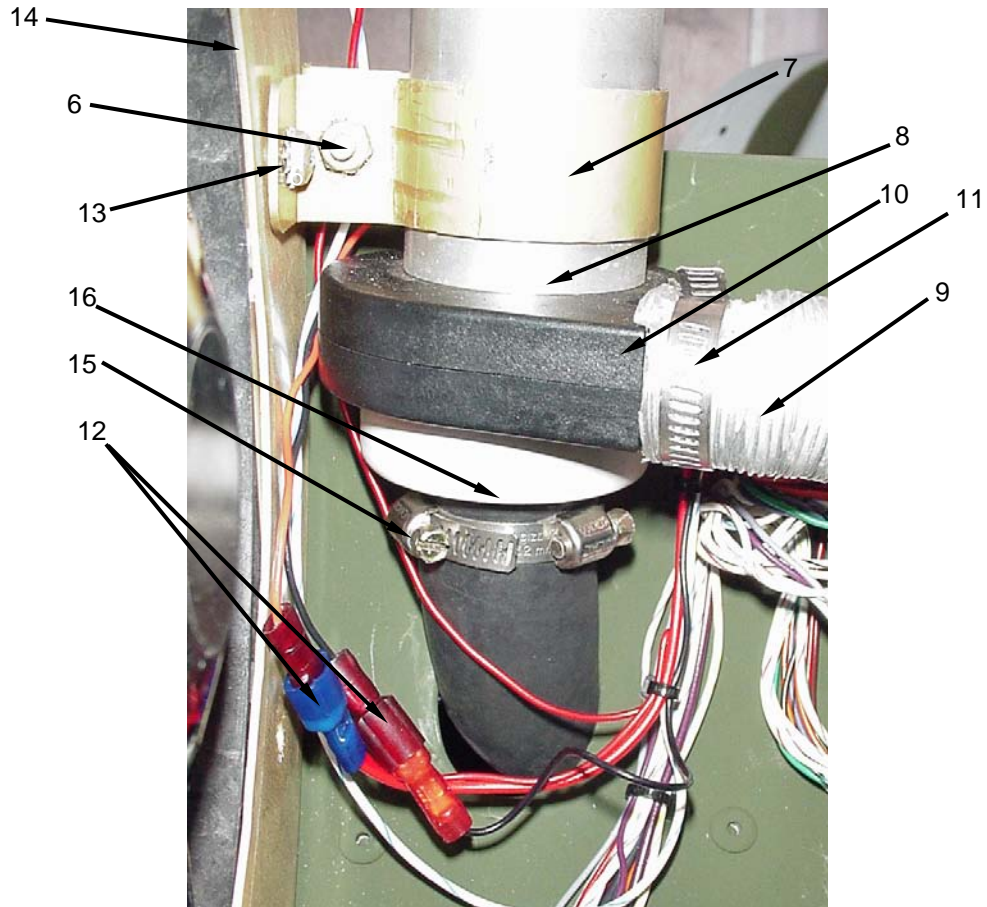

END OF WORK PACKAGE

UNIT MAINTENANCE
SPACE HEATER, CONVECTIVE

(NSN 4520-01-431-8927)

COMBUSTION AIR BLOWER DUCT ASSEMBLY
REPLACE

INITIAL SETUPTools

Tool Kit, General Mechanics (Item 1, WP 0044 00)

Materials/Parts**Personnel Required**

One

Equipment Condition

Heater shut down and all advisory lights off. (WP 0006 00)

In-tent controller cable assembly disconnected from heater. (WP 0006 00)

Fuel source disconnected. (WP 0006 00)

Battery disconnected. (WP 0006 00)

Upper housing assembly removed (WP 0030 00)

CAUTION

Disconnect battery connector. Before performing any maintenance actions, be sure to disconnect the battery to prevent component failure. Failure to comply may result in damage to electrical components.

REPLACE

1. Disconnect the combustion air blower duct assembly **(1)** from the burner assembly **(2)** by first loosening the hose clamp **(3)** and sliding it onto the hose **(1)**.
2. Pull the end of the duct **(1)** from the burner assembly **(2)**.
3. Disconnect the end of the combustion air blower duct assembly **(1)** connected to the combustion air blower assembly outlet **(4)** by loosening the hose clamp **(5)** and sliding it onto the hose **(1)**.
4. Remove the combustion air blower duct assembly **(1)** from the heater. Be sure to remove the rubber spacer sleeve located inside the end of the duct assembly and reinstall it onto the combustion air blower assembly outlet **(4)**.
5. To install the combustion air blower assembly hose **(1)**, connect the combustion air blower duct assembly to the burner assembly **(2)** by sliding it onto the hose inlet on the burner assembly **(2)**. Tighten the hose clamp **(3)**.
6. Slide the end of the combustion air blower duct assembly onto the combustion air blower assembly outlet **(4)**. Slide the hose clamp **(5)** into position and tighten.

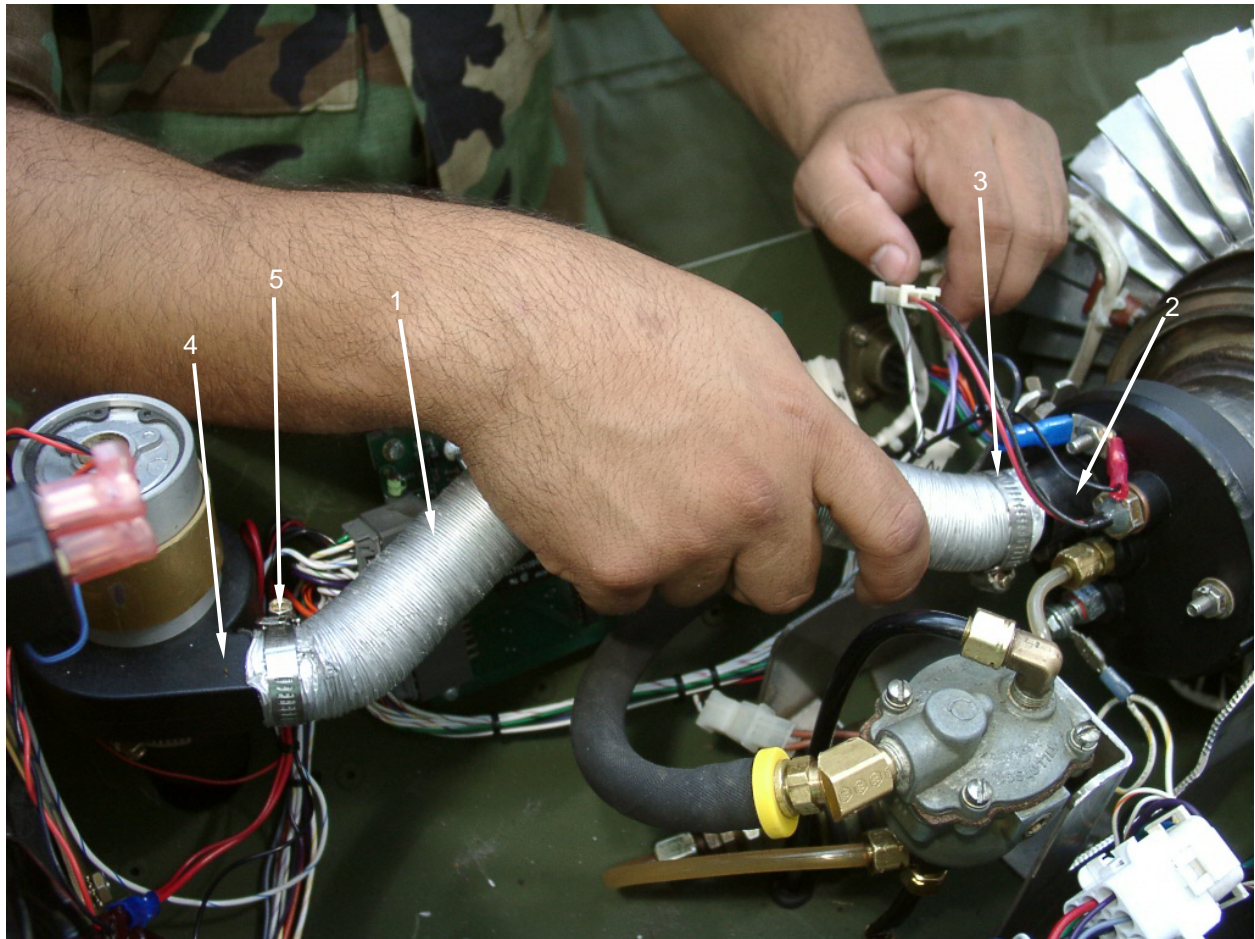

END OF WORK PACKAGE

UNIT MAINTENANCE
SPACE HEATER, CONVECTIVE
(NSN 5420-01-431-8927)
COMBUSTION AIR INLET ASSEMBLY
REPLACE

INITIAL SETUP**Tools**

Tool Kit, General Mechanics (Item 1, WP 0044 00)

Materials/Parts**Equipment Condition**

Heater shut down and all advisory lights off. (WP 0006 00)

In-tent controller assembly disconnected from heater. (WP 0006 00)

Fuel source disconnected. (WP 0006 00)

Upper housing assembly removed (WP 0030 00)

CAUTION

Disconnect battery connector. Before performing any maintenance actions, be sure to disconnect the battery to prevent component failure. Failure to comply may result in damage to electrical components.

REPLACE

1. To replace the combustion air inlet assembly **(1)**, turn the two, quarter-turn screws **(2)** securing the combustion air inlet cover **(3)** until they release and remove the cover from the lower housing assembly **(4)**.
2. Remove the two screws **(5)** that secure the combustion air inlet assembly bracket **(6)** to the lower housing assembly **(4)**.
3. Grasp the combustion air inlet fitting **(7)** and pull it off the end of the combustion air inlet assembly **(1)**.
4. Loosen the hose clamp **(8)** on the end of the combustion air inlet assembly **(1)** that connects to the combustion air blower assembly inlet **(9)** located inside the heater and pull the combustion air inlet assembly off the combustion air blower assembly inlet **(9)**. Remove the clamp **(8)** from the combustion air inlet assembly **(1)** and set aside.
5. Pull the combustion air inlet assembly **(1)** out of the heater from the outside of the lower housing assembly **(4)**.

6. To install a new combustion air inlet assembly (1), insert the longer end of the assembly into the opening on the lower housing assembly (4) and rotate it into position under the combustion blower assembly inlet (9). Slide the hose clamp (8) over the end of the combustion air inlet assembly (1).
7. Install the combustion air inlet assembly (1) over the combustion air blower assembly inlet (9). Note that a slight back and forth rotating motion may be required. Tighten the hose clamp (8) securely.
8. Position the combustion air inlet assembly (1) against the lower housing assembly (4) and install the combustion air inlet fitting (7) over the end of the combustion air inlet assembly (1).
9. Position the bracket (6) over the end of the combustion air inlet (1). Secure with two screws (5).
10. Install the combustion air inlet cover (3) and secure with two quarter-turn screws (2).

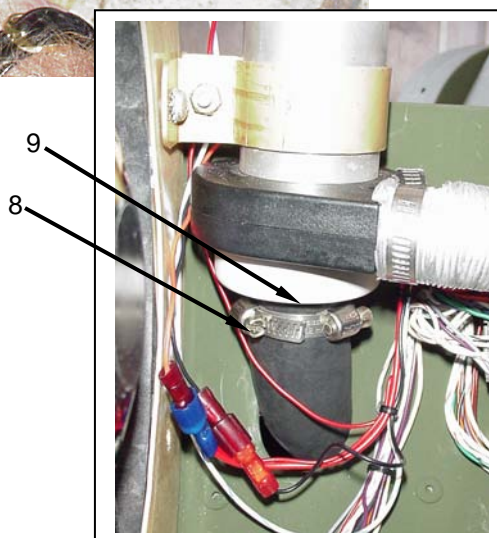

END OF WORK PACKAGE

UNIT MAINTENANCE
SPACE HEATER, CONVECTIVE
(NSN 4520-01-431-8927)

UPPER HOUSING ASSEMBLY
SERVICE, REPLACE

INITIAL SETUP**Tools**

Tool Kit, General Mechanics (Item 1, WP 0044 00)

Materials/Parts

Silicone lubricant (Item 4, WP 0067 00)

Equipment Condition

Heater shut down and all advisory lights off. (WP 0006 00)

CAUTION

Disconnect battery connector. Before performing any maintenance actions, be sure to disconnect the battery to prevent component failure. Failure to comply may result in damage to electrical components.

SERVICE

Lubricate slide portion **(1)** and pivot **(2)** of adjusting handle **(3)** with silicone lubricant.

REPLACE

1. To replace the upper housing assembly **(4)**, remove the two dust covers **(5)** and set aside.
2. Release the fasteners **(6)** that secure the two duct adapters **(7)** to the heater housing **(8)**. Remove the two duct adapters **(7)** and set aside.
3. Release the four fasteners **(9)** that secure the upper housing assembly **(4)** to the lower housing assembly **(10)**.
4. Lift the upper housing assembly **(4)** up and off the lower housing assembly **(10)**.
5. Install a new upper housing assembly **(4)** and align with the lower housing assembly **(10)**. Align the four fasteners **(9)** with their corresponding keeper plates.
6. Secure all four fasteners **(9)**.

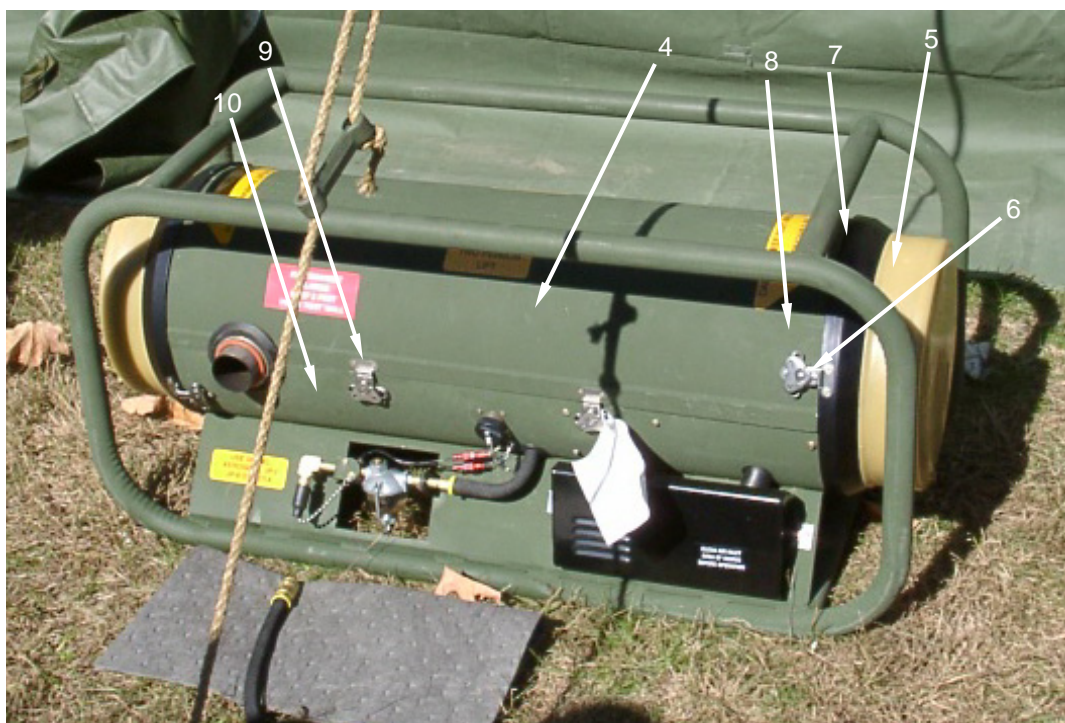
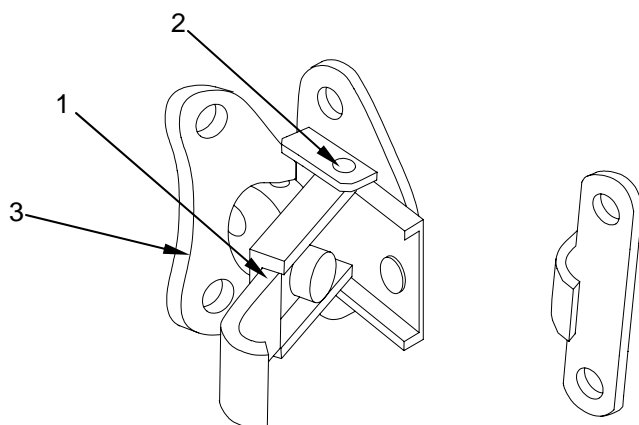

END OF WORK PACKAGE

UNIT MAINTENANCE
SPACE HEATER, CONVECTIVE

(NSN 5420-01-431-8927)

**EXHAUST GROMMET
REPLACE**

INITIAL SETUP

Tools

Tool Kit, General Mechanics (Item 1, WP 0044 00)

Materials/Parts

Personnel Required

One

Equipment Condition

Heater shut down and all advisory lights off. (WP 0006 00)

In-tent controller assembly disconnected from heater. (WP 0006 00)

Fuel source disconnected.(WP 0006 00)

Battery disconnected. (WP 0018 00)

Upper housing assembly removed (WP 0030 00)

CAUTION

Disconnect battery connector. Before performing any maintenance actions, be sure to disconnect the battery to prevent component failure. Failure to comply may result in damage to electrical components.

REPLACE

1. To remove the exhaust grommet **(1)**, remove the exhaust O-ring **(2)** and set aside.
2. Loosen the two wing nuts **(3)** that secure the burner assembly **(4)**. Loosening the wing nuts will permit the heat exchanger **(5)** to be tilted upward to allow access to the grommet.
3. Tilt the end of the heat exchanger **(5)** upward and slide the grommet **(1)** up and out of the slotted recess on the lower housing assembly **(6)**.
4. Stretch the grommet **(1)** over the ridge on the combustion exhaust pipe and slide the grommet off the combustion exhaust pipe **(7)**.
5. Install a new exhaust grommet **(1)** by sliding the grommet over the combustion exhaust pipe **(7)**. Lift up slightly on the heat exchanger **(5)** and engage the slot **(8)** in the grommet **(1)** over the sheet metal recess **(9)** on the lower housing assembly **(6)**.
6. Press the exhaust grommet **(1)** down firmly.

UNIT MAINTENANCE
SPACE HEATER, CONVECTIVE
(NSN 4520-01-431-8927)

DUCT ADAPTER
REPLACE

INITIAL SETUP**Tools**

Tool Kit, General Mechanics (Item 1, WP 0044 00)

Personnel Required

One

Materials/Parts**Equipment Condition**

Heater shut down and all advisory lights off. (WP 0006 00)

Dust covers removed. (WP 0026 00)

CAUTION

Disconnect battery connector. Before performing any maintenance actions, be sure to disconnect the battery to prevent component failure. Failure to comply may result in damage to electrical components.

REPLACE

1. To remove the duct adapter **(1)**, lift and rotate the fastener housing **(2)**, releasing it from the fastener keeper **(3)** on the upper housing assembly **(4)**.
2. Repeat for the second fastener housing **(5)** and keeper on the opposite side of the duct adapter **(1)**.
3. Pull the duct adapter **(1)** from the heater body **(6)**.
4. To install a new duct adapter **(1)**, align it over the end of the heater body **(6)** and press it into position.
5. Engage the fastener housings and keepers **(2, 3 and 5)** on both sides of the duct adapter **(1)** and secure in place.



END OF WORK PACKAGE

UNIT MAINTENANCE
SPACE HEATER, CONVECTIVE

(NSN 4520-01-431-8927)

HEATED AIR BLOWER ASSEMBLY
INSPECT, TEST, REPLACE

INITIAL SETUPTools

Tool Kit, General Mechanics (Item 1, WP 0044 00)

Personnel Required

One

Materials/Parts

N/A

Equipment Condition

Heater shut down and all advisory lights off. (WP 0006 00)

In-tent control assembly disconnected from heater. (WP 0006 00)

Fuel supply disconnected. (WP 0006 00)

Battery disconnected. (WP 0018 00)

Upper housing assembly removed (WP 0030 00)

CAUTION

Disconnect battery connector. Before performing any maintenance actions, be sure to disconnect the battery to prevent component failure. Failure to comply may result in damage to electrical components.

INSPECT

1. Inspect the heated air blower assembly **(1)** for cracks, dents, or other damage that would prevent the heated air blower assembly from rotating freely.
2. Inspect the inlet **(2)** and outlet **(3)** side of the heated air blower assembly **(1)** for any debris or blockages that would restrict the flow of air through the heater.

TEST

1. Separate the positive (+) **(1)** and negative **(2)** electrical connectors of the heated air blower assembly **(3)**.
2. Set multi-meter to measure resistance.
3. Place probe No. 1 against positive terminal **(1)** and probe No. 2 against negative terminal **(2)**. Normal meter indication is a minimum of 5.2 megohms.
4. If meter reading indicates a short or an open circuit, replace heated air blower assembly **(3)**.
5. Reconnect the heated air blower assembly connector **(1)** and **(2)**.

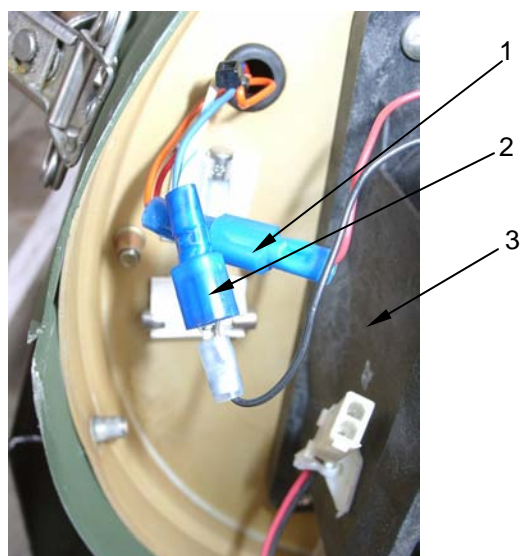
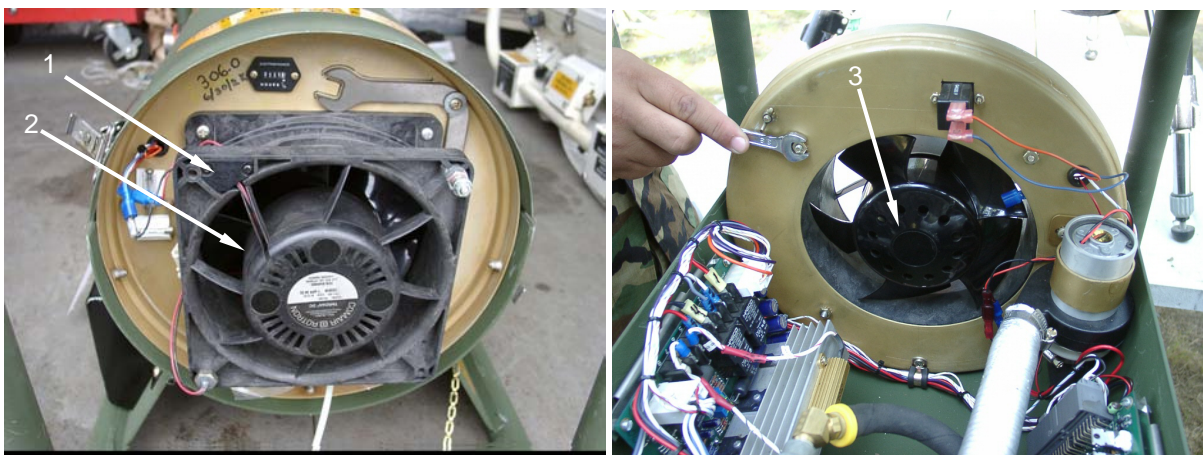

REPLACE

1. To replace the heated air blower assembly **(1)**, remove any spare parts **(2)** that may be stored in the corner holes of the vent fan and set aside.
2. Disconnect the heated air blower assembly connectors **(3 and 4)**.
3. Loosen and remove the four screws **(5)**, nuts **(6)**, and lock washers **(7)** that mount the heated air blower assembly **(1)** to the heater air blower assembly housing **(8)**.
4. Remove the heated air blower assembly **(1)**.
5. To install the heater air blower assembly **(1)**, position over the four holes on the heated air blower assembly housing **(8)**.

6. Install four screws (5), nuts (6), and lock washers (7) at the four corners of the heated air blower assembly (1). Tighten securely.
7. Reconnect heated air blower assembly electrical connectors (3 and 4).

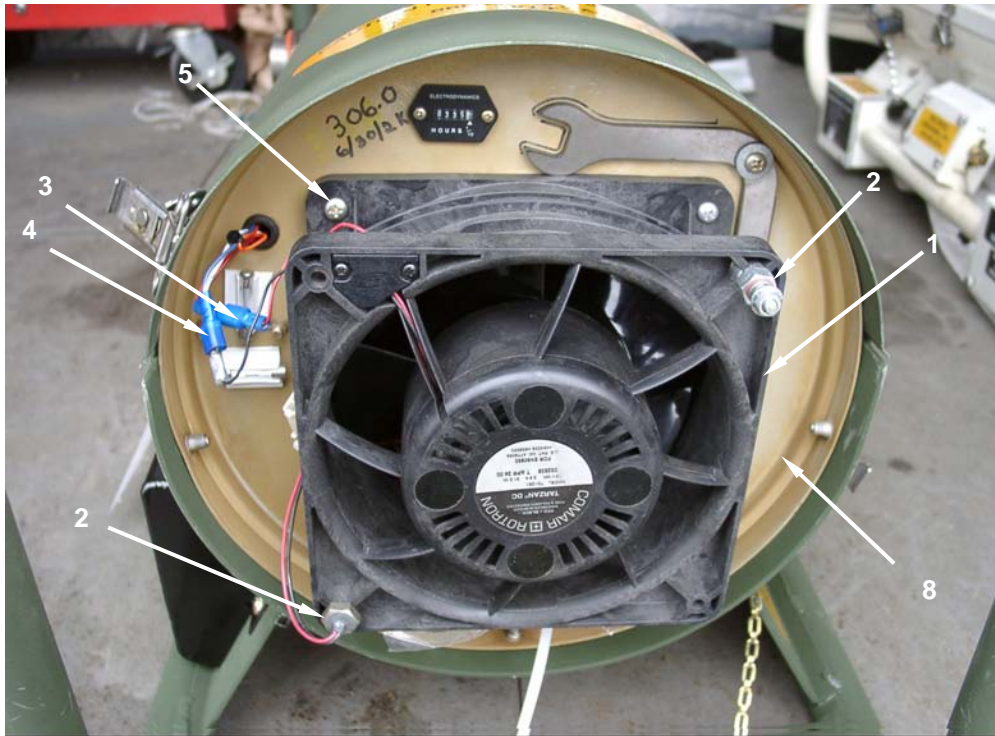

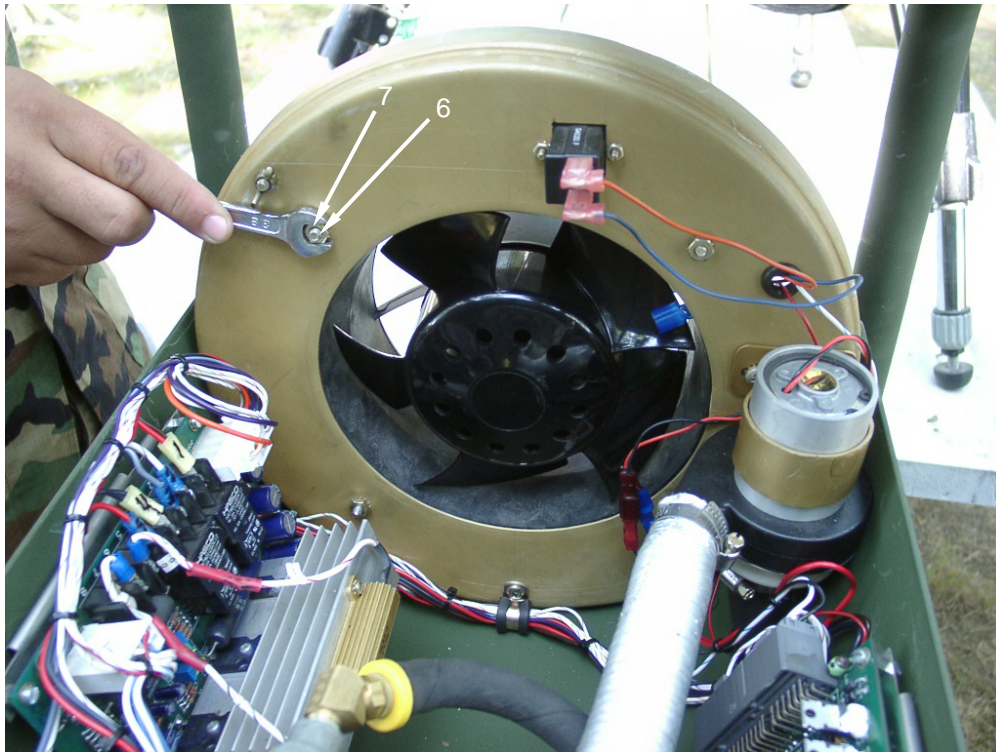

END OF WORK PACKAGE

UNIT MAINTENANCE
SPACE HEATER, CONVECTIVE
(NSN 4520-01-431-8927)

FUEL PUMP
TEST, REPLACE

INITIAL SETUP**Tools**

Tool Kit, General Mechanics (Item 1, WP 0044 00)

Materials/Parts

Mat, Petroleum Absorbent (Item 15, WP 0067 00)
Tray, Petroleum Absorbent (Item 17, WP 0067 00)

Equipment Condition

Heater shut down and all advisory lights off. (WP 0006 00)

In-tent controller assembly disconnected from heater. (WP 0006 00)

Fuel supply disconnected. (WP 0006 00)

Battery disconnected. (WP 0018 00)

Upper housing assembly removed. (WP 0030 00)

CAUTION

Disconnect battery connector. Before performing any maintenance actions, be sure to disconnect the battery to prevent component failure. Failure to comply may result in damage to electrical components.

TEST

1. Disconnect the electrical connector **(1)**.
2. Check the fuel pump **(2)** continuity with an ohmmeter. It should read 8 ohms.
3. If it has a reading other than 8 ohms, replace the fuel pump.

REPLACE

1. To remove the fuel pump **(2)**, disconnect the electrical connector **(1)**.
2. Remove the screw **(3)** that secures the fuel pump bracket **(4)** to the lower housing assembly **(5)**.
3. Loosen the screw **(6)** on the outlet hose **(7)** of the fuel pump **(2)** and pull the fuel line **(8)** out of the outlet hose **(7)**. Drain any fuel onto a petroleum absorbent mat or tray.
4. Loosen and remove the fitting **(9)** on the float assembly **(10)**. Drain any fuel onto a petroleum absorbent mat or tray.
5. Note the position of the fuel pump in the heater. The fuel pump must be reinstalled in the same position. Remove the fuel pump **(2)** from the heater and place on a petroleum absorbent mat or tray. Wipe up any fuel that may spill.
6. Remove the fuel pump bracket **(4)** and screw **(3)** and set aside.
7. While working on petroleum absorbent material, loosen and remove the fuel line **(11)** leading to the inlet end **(12)** of the fuel pump. Set the fuel line aside.
8. To install a new fuel pump, install the fuel line **(11)** to the inlet end **(12)** of the fuel pump. Tighten the fitting securely.
9. Slide the fuel pump bracket **(4)** over the new fuel pump and place the fuel pump **(2)** in position so that the fitting **(9)** on the end of the fuel line attached lines up with the "T" fitting **(13)** on the float assembly **(10)**.
10. Position the fuel pump bracket **(4)** over the hole in the lower housing assembly **(5)** and install the screw **(3)**. Tighten securely.
11. Engage the fitting **(9)** on the "T" fitting **(13)** of the float assembly **(10)** and tighten securely.
12. Install the fuel line **(8)** in the outlet hose **(7)** at the outlet end of the fuel pump and tighten the screw **(6)** on the hose clamp securely.
13. Install electrical connector **(1)**.

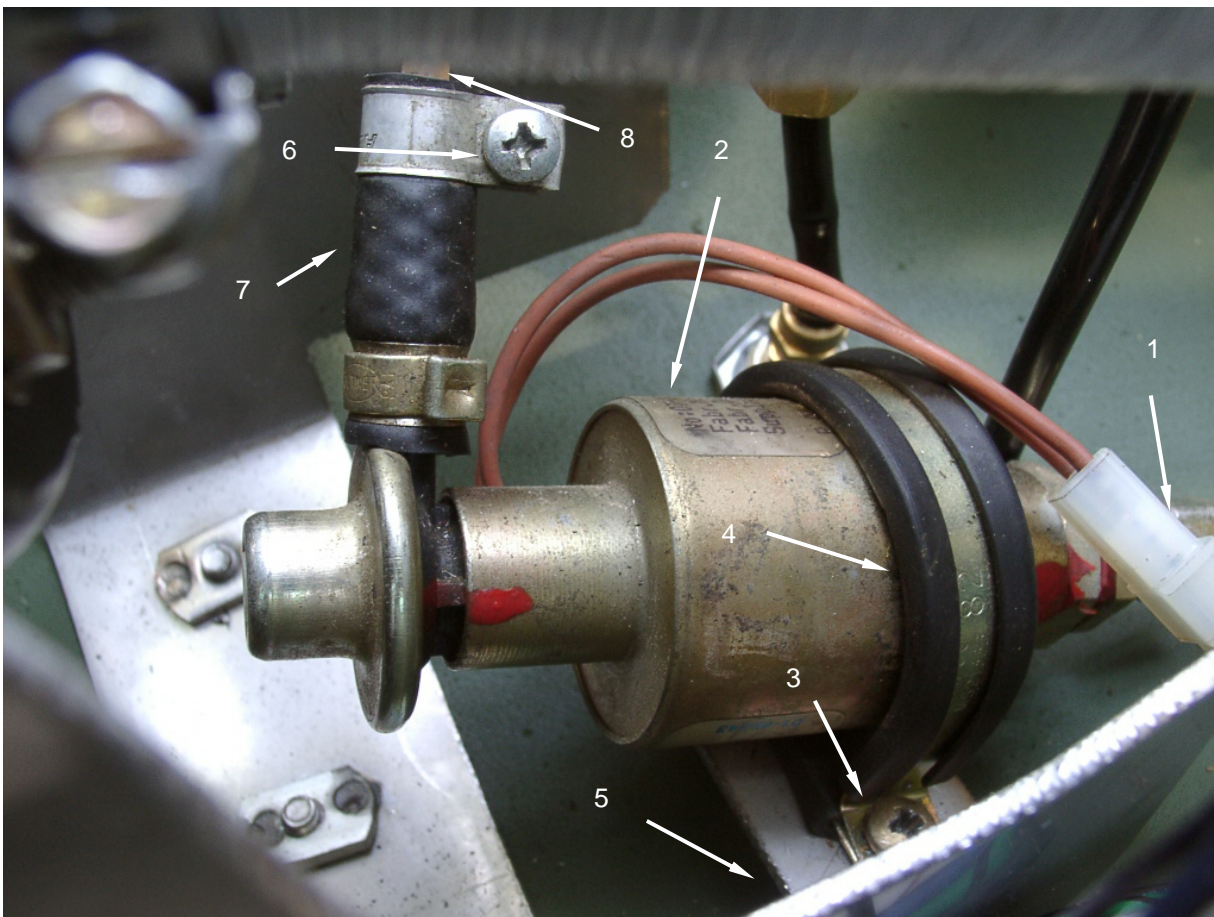

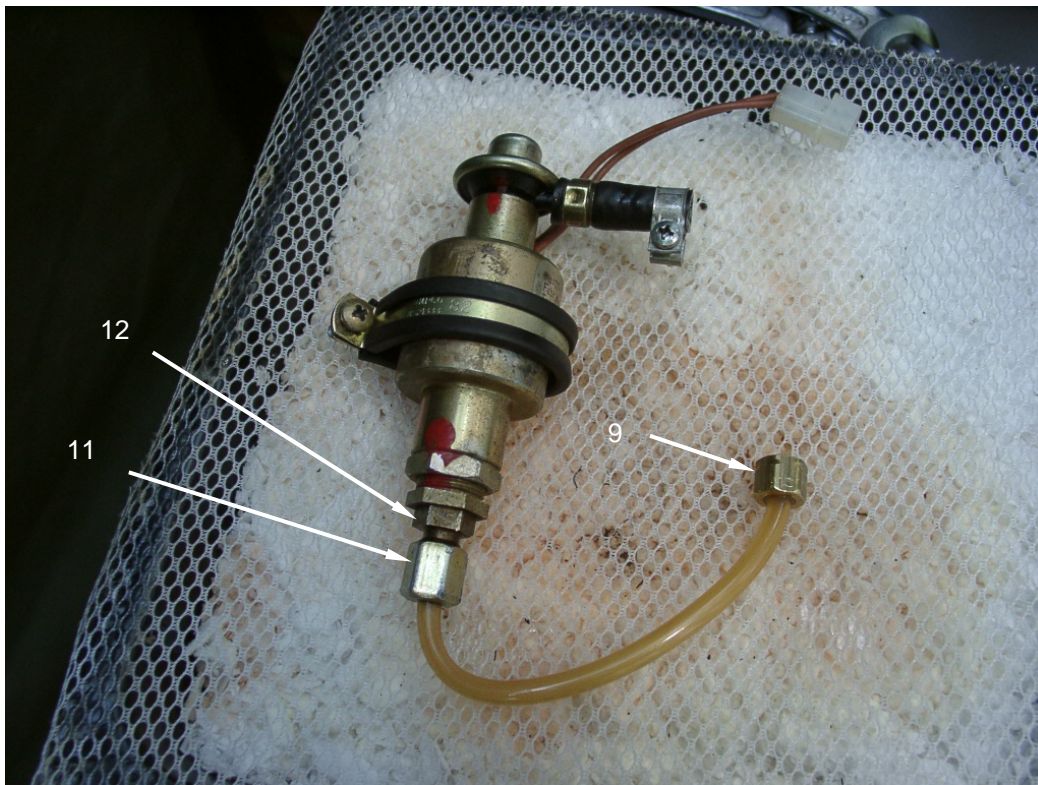
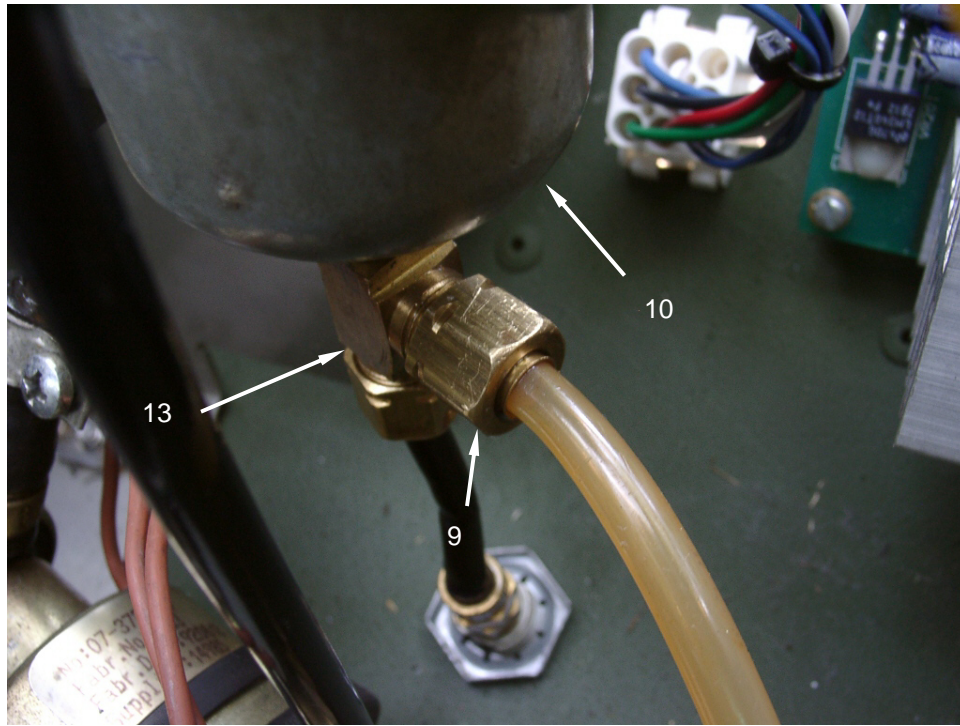

END OF WORK PACKAGE

Change 1

0034 00-4

UNIT MAINTENANCE
SPACE HEATER, CONVECTIVE
(NSN 4520-01-431-8927)
INTERNAL FUEL LINES
REPLACE

INITIAL SETUP**Tools**

Tool Kit, General Mechanics (Item 1, WP 0044 00)

Materials/Parts**Equipment Condition**

Heater shut down and all advisory lights off. (WP 0006 00)

In-tent controller assembly disconnected from heater. (WP 0006 00)

Fuel source disconnected. (WP 0006 00)

Upper housing assembly removed. (WP 0030 00).

Battery disconnected. (WP 0018 00)

CAUTION

Disconnect battery connector. Before performing any maintenance actions, be sure to disconnect the battery to prevent component failure. Failure to comply may result in damage to electrical components.

REPLACE

There are two internal fuel lines that are constructed of a heat formed plastic material (this does not include the fuel hose which is covered in WP 0021 00). One line extends from the outlet end of the fuel pump to the inlet of the burner assembly and the second extends from the "T" connector at the base of the float assembly to the inlet of the fuel pump. A third plastic fuel drain line extends from the top of the float assembly through the lower housing assembly. All internal fuel lines utilize brass compression fittings and all are removed and replaced in the same fashion.

1. To remove an internal fuel line **(1)**, loosen the fitting **(2)** at each end of the fuel line, taking care not to spill the fuel that may be contained in the line. Drain the fuel into an approved container. Wipe up any fuel that may spill in the lower housing assembly **(3)** or on any of the components.
2. Note the orientation of the fuel line in the heater, the replacement fuel line must be installed in the same orientation.
3. Remove the fuel line **(1)** from the heater.

4. Install a new fuel line **(1)** in the same position as the line being replaced.
5. Slide the fitting nut **(2)** over the fuel line followed by the compression fitting sleeve **(4)** (if used). Tighten the compression fitting nut **(2)** securely but do not over tighten.
6. Repeat for fitting on opposite end of fuel line.

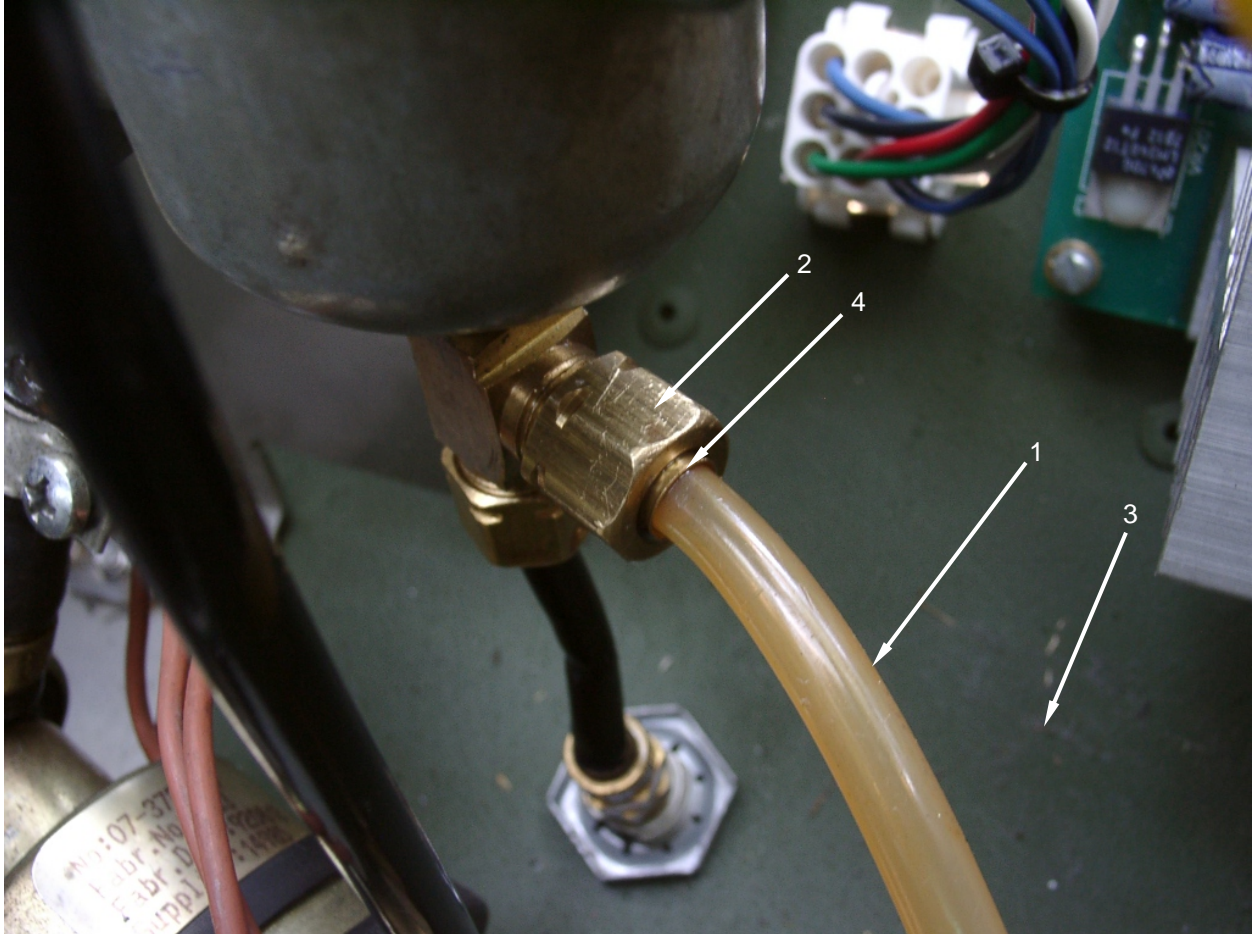

END OF WORK PACKAGE

UNIT MAINTENANCE**SPACE HEATER, CONVECTIVE****(NSN 4520-01-431-8927)****FLOAT ASSEMBLY
REPLACE****INITIAL SETUP****Tools**

Tool Kit, General Mechanics (Item 1, WP 0044 00)

Materials/Parts

Sealant, Thread (Item 3, WP 0067 00)

Rags, Wiping, Clean (Item 5, WP 0067 00)

Equipment Condition

Heater shut down and all advisory lights off. (WP 0006 00)

In-tent controller assembly disconnected from heater. (WP 0006 00)

Fuel supply disconnected. (WP 0006 00)

Sediment strainer emptied of fuel. (WP 0020 00).

Upper housing assembly removed. (WP 0030 00).

Battery disconnected. (WP 0018 00)

CAUTION

Disconnect battery connector. Before performing any maintenance actions, be sure to disconnect the battery to prevent component failure. Failure to comply may result in damage to electrical components.

REPLACE

1. To replace the float assembly **(1)** loosen and remove the fuel drain line fitting **(2)** on the top assembly **(3)**.
2. Remove the fuel hose **(4)** from the float assembly inlet fitting **(5)** in accordance with WP 0021 00.
3. Remove the float assembly inlet fitting **(5)** and set aside. Take note of the orientation of the fitting as it will be installed on the new float assembly in the same orientation. Clean any residual thread sealant from the threads of the fitting **(5)** and set aside.
4. Loosen and remove the two fuel line fittings **(6 and 7)** that attach to the "T" connector **(8)** at the base of the float assembly **(1)**.
5. Loosen and remove the two screws **(9)** that secure the float assembly **(1)** to the float assembly bracket **(10)**.

6. Remove the float assembly **(1)** from the heater and move it onto a petroleum absorbent mat or tray. Wipe up any spilled fuel.
7. Take note of the orientation of the "T" connector **(8)** at the base of the float assembly **(1)**. Remove the "T" connector **(8)**, clean any residual thread sealant from the threads of the connector and set aside.
8. Take note of the orientation of the elbow connector **(11)** at the top of the float assembly **(1)**. Remove the elbow connector **(11)**, clean any residual thread sealant from the threads of the connector and set aside.
9. To install a new float assembly **(1)**, apply thread sealant on the threads at the base of the float assembly and install the "T" connector **(8)** removed earlier, making sure to orient the connector as it was on the defective float assembly.
10. Apply thread sealant on the threads of the elbow connector **(11)** removed earlier and install the elbow connector on the top of the new float assembly, taking care to orient the elbow connector **(11)** as it was on the defective float assembly.
11. Position the float assembly on the bracket **(10)** and secure with two screws **(9)**.
12. Install the two fuel lines fittings **(6 and 7)** on the "T" connector **(8)** at the base of the float assembly. Tighten fittings **(6 and 7)** securely.
13. Apply new thread sealant to the threads of the float assembly inlet fitting **(5)** and install at the inlet **(12)** of the float assembly **(1)** taking care to orient the opening of the fitting as it was on the defective float assembly.
14. Install the fuel hose **(4)** on the float assembly inlet fitting **(5)** IAW WP 0021 00.
15. Install and tighten the fuel drain fitting **(2)** on the top assembly **(3)**.

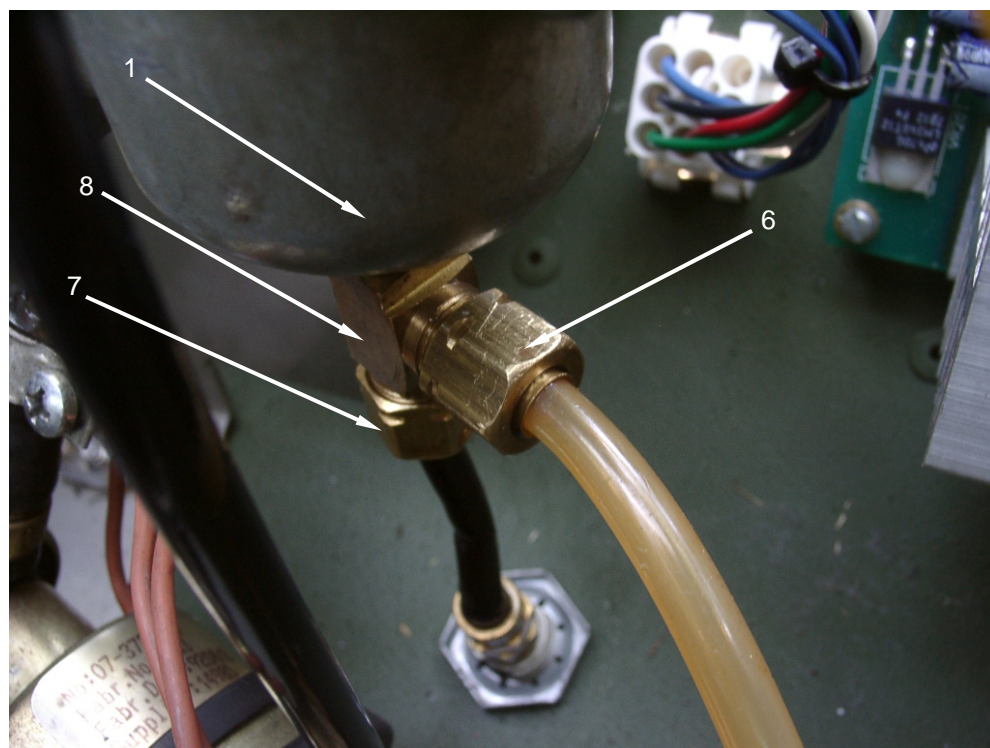
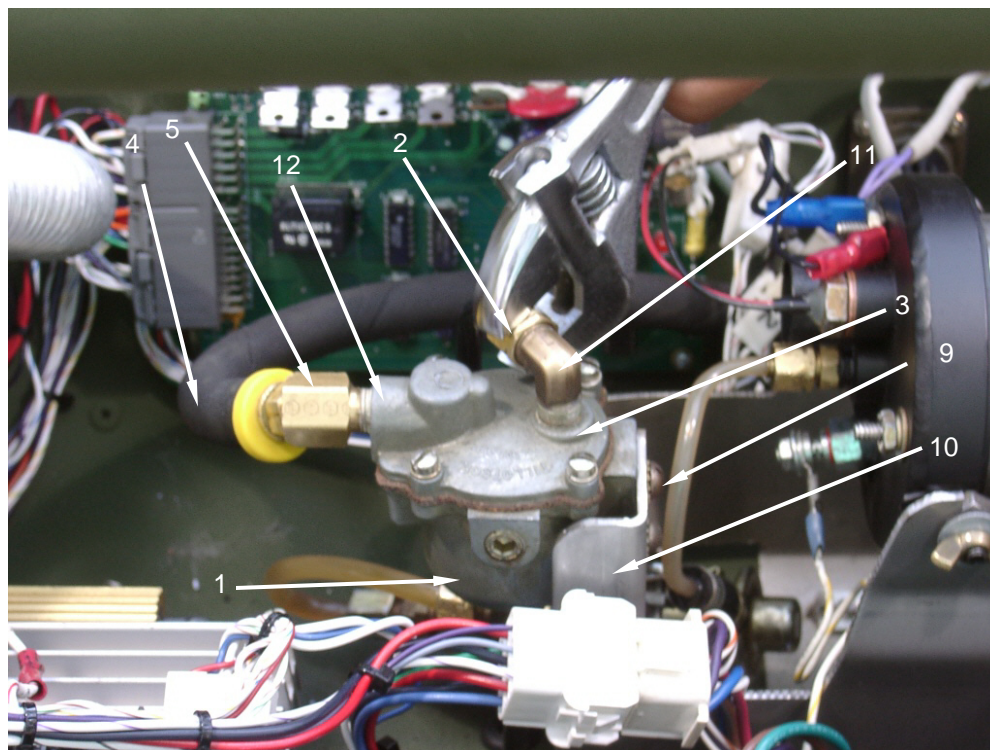

END OF WORK PACKAGE

UNIT MAINTENANCE**SPACE HEATER, CONVECTIVE****(NSN 4520-01-431-8927)****BURNER ASSEMBLY
REMOVE, INSPECT, SERVICE, REPLACE****INITIAL SETUP****Tools**

Tool Kit, General Mechanics (Item 1, WP 0044 00)

Materials/Parts

Rags, Wiping, Clean (Item 9, WP 0067 00)

Kit, Burner (Item 19, WP 0067 00)

Tags, marking, (Item 6, WP 0067 00)

Mat, Petroleum Absorbent, (Item 10, WP 0067 00)

Wire brush (Item 8, WP 0067 00)

Personnel Required

One

Equipment Condition

Heater shut down and all advisory lights off. (WP 0006 00)

In-tent controller assembly disconnected from heater. (WP 0006 00)

Fuel source disconnected. (WP 0006 00)

Sediment Strainer emptied of fuel. (WP 0020 00)

Battery disconnected. (WP 0018 00)

Upper housing assembly removed. (WP 0023 00)

REMOVE**WARNING**

Drain fuel into a container and dispose of fuel in a safe manner. Catch and retain all residual fuel. Promptly wipe up any spilled fuel. Dispose of fuel IAW unit SOP. Failure to comply may result in injury to personnel.

CAUTION

Disconnect battery connector. Before performing any maintenance actions, be sure to disconnect the battery to prevent component failure. Failure to comply may result in damage to electrical components.

NOTE

Leaking or spilled fuels will harm the environment. Follow all local requirements when cleaning up all fuel spills.

1. Place a petroleum absorbent mat under the burner assembly to catch any fuel that may spill.



2. Release and remove the burner to thermoelectric generator (TEG) V-clamp by loosening the two nuts **(1)**, opening the clamp, and moving it off the flanges between the TEG and burner assembly.

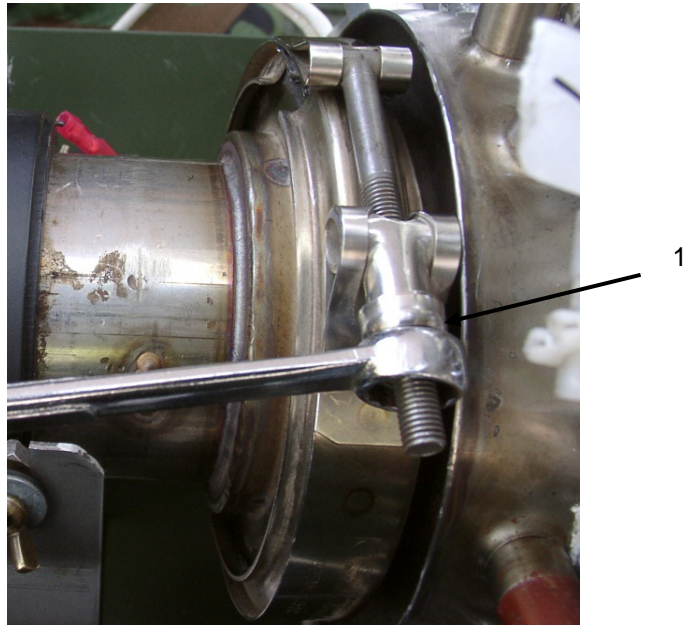

3. Disconnect fuel line **(2)** extending from the fuel pump **(3)** to the burner assembly **(4)** at fitting **(5)**. Carefully collect fuel that may spill from the hose. Wipe up any spilled fuel.
4. Tag and disconnect wire from flame sensor **(6)** and wire from glow plug **(7)**.
5. Tag and disconnect the two ground wires **(8 and 9)**.
6. Disconnect combustion air inlet duct **(10)** by loosening hose clamp **(11)** and sliding the clamp up the duct. Pull the combustion air inlet duct off the burner assembly air inlet and move off to the side.

NOTE

This will tear the graphite ribbon tape and is normal; new graphite ribbon tape will be installed when the burner is replaced.

7. Loosen the two wing nuts **(12)** on either side of the burner assembly bracket. Lift and pull burner assembly **(4)** up out of the burner bracket and away from TEG **(13)**.
8. Lift out burner assembly **(4)** when the screws have cleared slots in burner bracket **(14)**, and then place on suitable work surface.

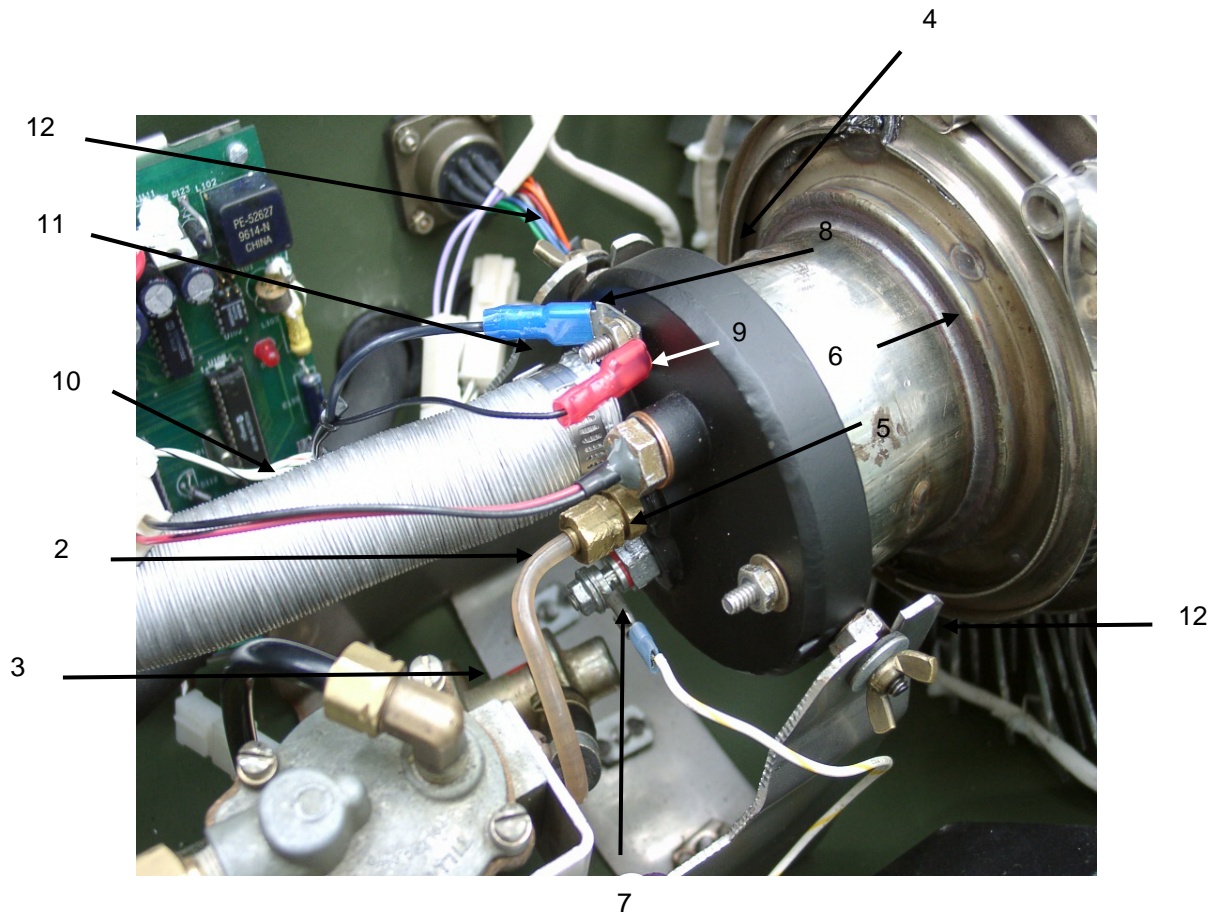

9. Clean any residual graphite ribbon tape from the TEG flange (13), burner assembly flange (15), and the inside of the burner to TEG V-clamp (16).
10. Remove the three nuts and lock washers (17), and quick connect tab (18) and set aside. Disassemble the burner assembly into its separate components.

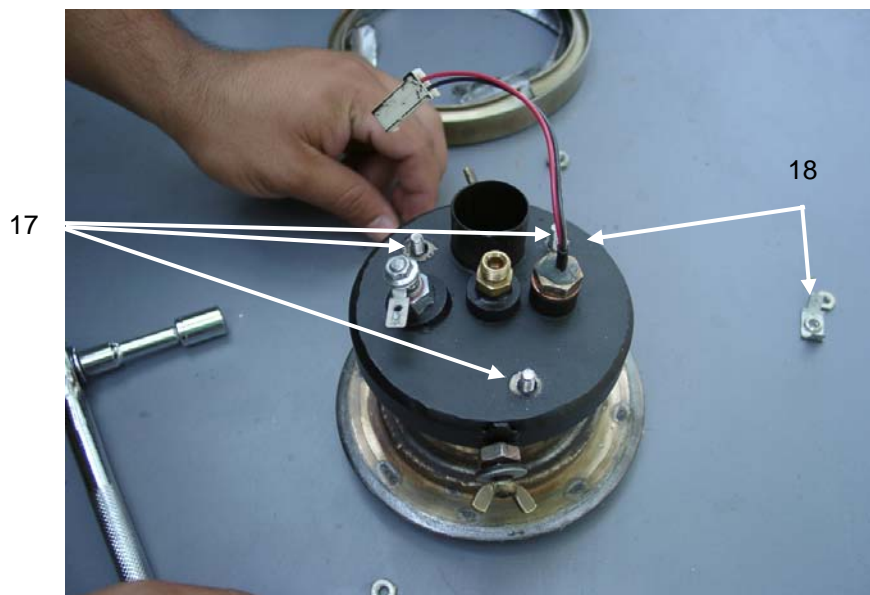
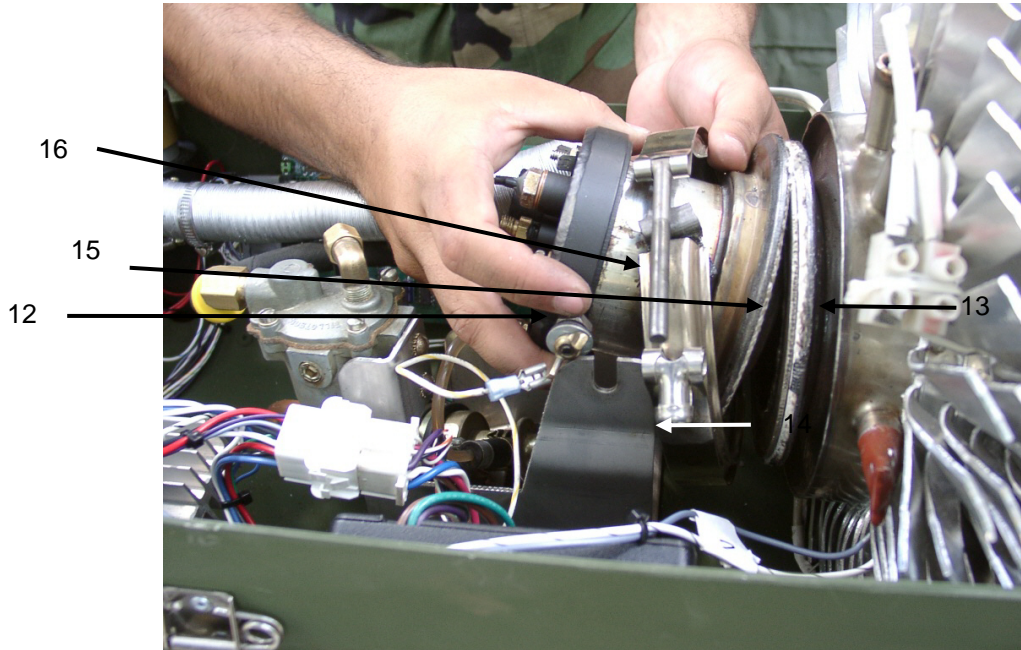

INSPECT

1. Inspect the burner assembly components **(1)** for any bends, dents, or other damage that would prevent the components from fitting together properly.

Inspect the vaporizer assembly **(2)** to ensure that it does not have any holes and is not plugged. If the vaporizer has holes or is plugged, replace the entire burner assembly as detailed later in this work package.

3. Inspect the vaporizer assembly **(2)** and ensure that it does not have a carbon buildup. If so, clean the vaporizer assembly as described in Service procedure below.
4. Inspect the inside of the burner assembly **(3)** and ensure that it does not have a carbon buildup. If so, clean the inside of the burner assembly as described in Service procedure below.

NOTE

A vaporizer assembly in excess of 600 hours run time may exhibit the properties listed in step 5.

5. Inspect the vaporizer assembly **(2)** for signs of wear, such as oxidation of either the vaporizer screen or the vaporizer washer. If signs of wear exist, replace the burner assembly as described in Replace procedure.
6. Reassemble burner assembly components and install burner assembly as detailed in the Service procedure below.



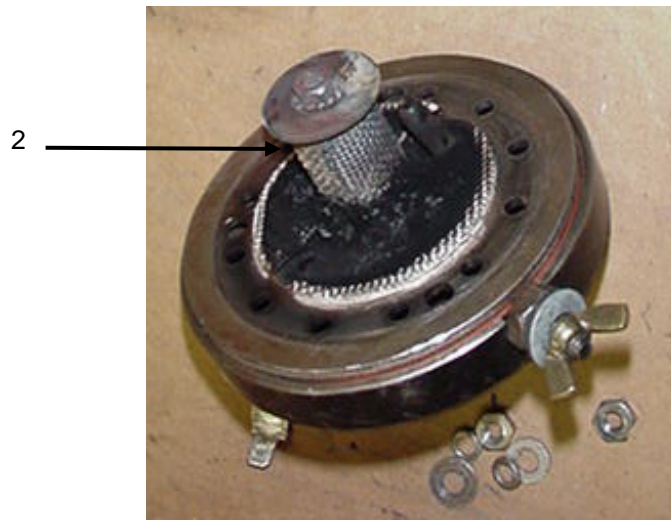
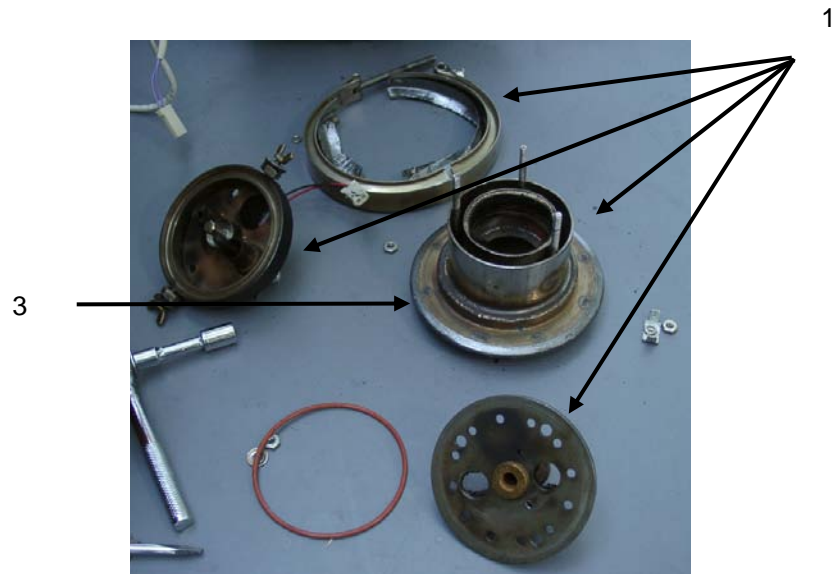

SERVICE

WARNING

Leaking or spilled fuels will create a fire danger-injuries/death and environmental damage. Fuel spills shall be cleaned up in accordance with local requirements.

CAUTION

Disconnect battery connector. Before performing any maintenance actions, be sure to disconnect the battery to prevent component failure. Failure to comply may result in damage to electrical components.

1. Capture any residual fuel on the burner assembly **(1)** using the petroleum absorbent mat.
2. Tag and disconnect the glow plug lead **(2)**, flame sensor connector **(3)**, and ground leads **(4)** and **(5)**.
3. Disconnect the fuel line **(6)**, and combustion air blower duct **(7)** from the burner assembly **(1)**.
4. Tag and disconnect the TEG electrical connectors **(8)** and **(9)**.



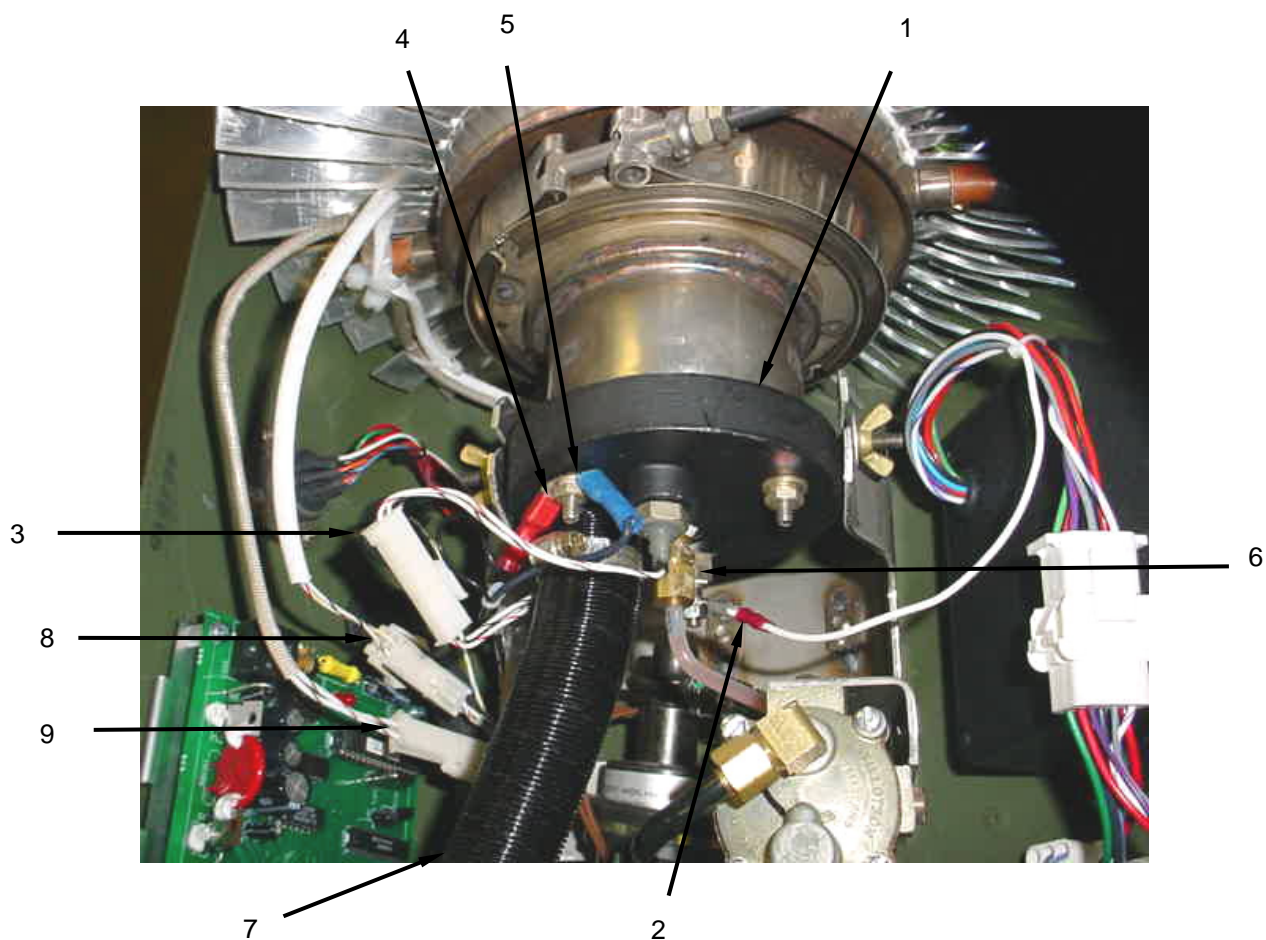

NOTE

Do not loosen the top screws for the wires that enter the interior of the TEG.

5. Tag and disconnect the two wires (10) going into the modular connector (11) on the side of the TEG by loosening the two bottom screws.

CAUTION

Take care not to bend any of the fins on the TEG. Damaging the fins reduces airflow and directly affects the performance of the system. Failure to comply may result in damage to the equipment.

6. Loosen the wing nuts (12) on the side of the burner assembly (1) and lift assembled heat exchanger (13) and TEG (14) and remove from heater.

7. Place the burner assembly (1), heat exchanger (13) and TEG (14) on an appropriate work surface with the burner end up.
8. Leave the air guide wrap (15) in place.

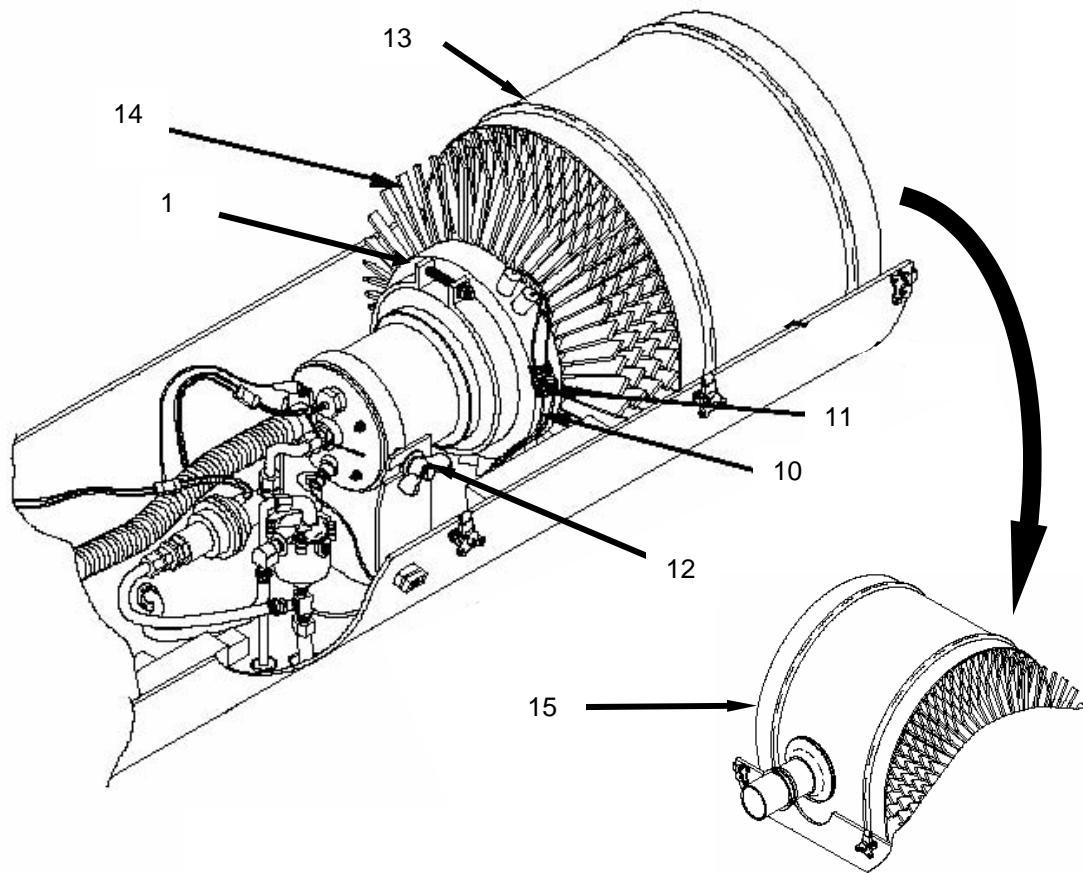

9. Loosen and remove three sets of nuts, lock washers, washers (16) and the quick connect tab from the burner head (17).



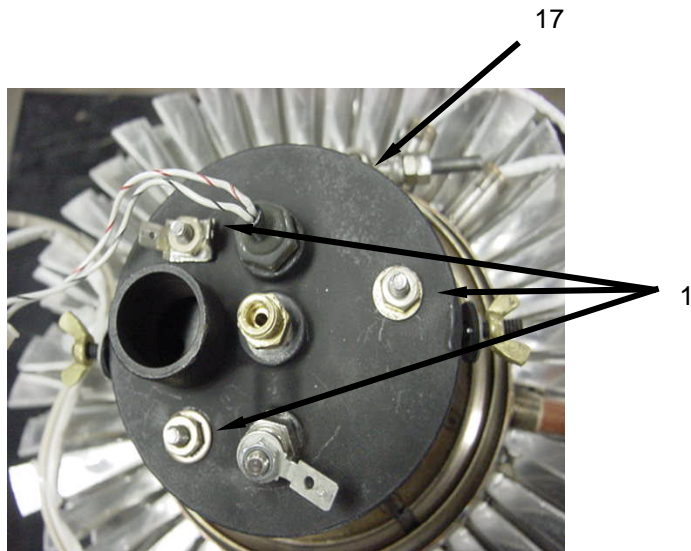

CAUTION

Do not disassemble the o-ring that seals the vaporizer to the burner head. The o-ring may swell making it difficult or impossible to reassemble. Failure to comply may result in damage to the equipment.

10. Remove the burner head and vaporizer assembly **(19)** as shown.
11. Gently scrape the surface to remove the carbon deposits from the vaporizer assembly **(19)**, glow plug **(2)** and flame sensor **(3)** area.

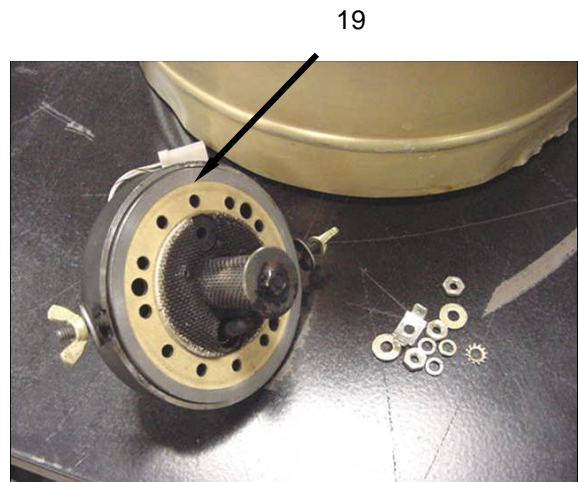
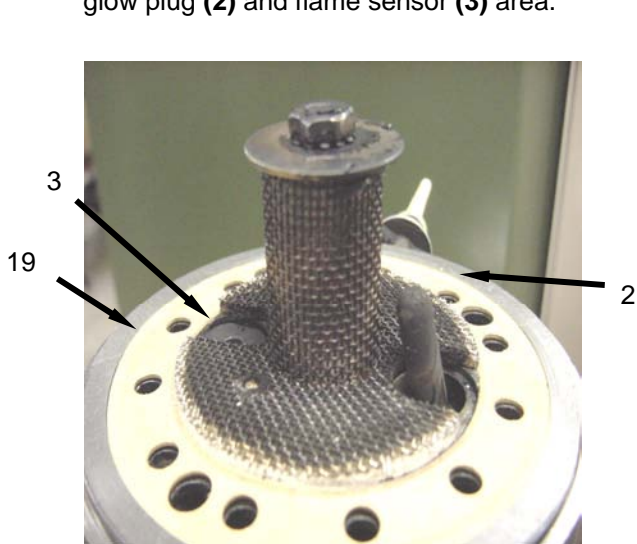

12. Gently scrape the surface to remove the carbon deposits from the inside of the burner assembly (1).



13. Return the burner head (17) to the top of the assembly.



14. Install the washers, lock washers, nuts (16), quick connect tab and to the burner head (17).

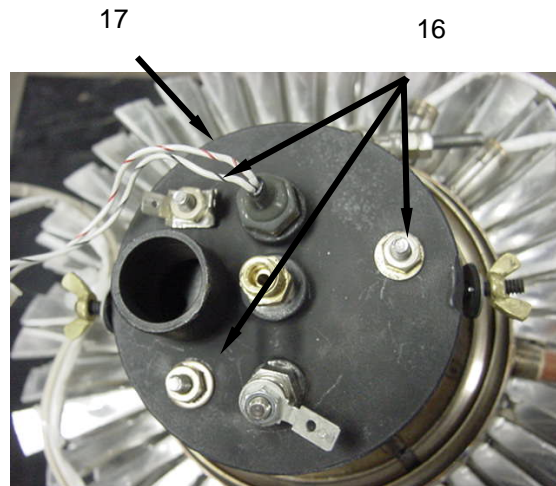

Place assembled burner assembly, heat exchanger and TEG into heater and align exhaust port **(20)** and grommet with exhaust cutout **(21)** in the lower housing.

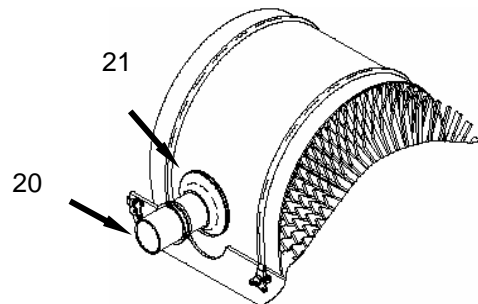

16. Tighten wing nuts **(12)** on side of burner assembly **(1)**.

17. Remove the tags and connect the wires **(10)** to the TEG cooling fin modular connector **(11)**.

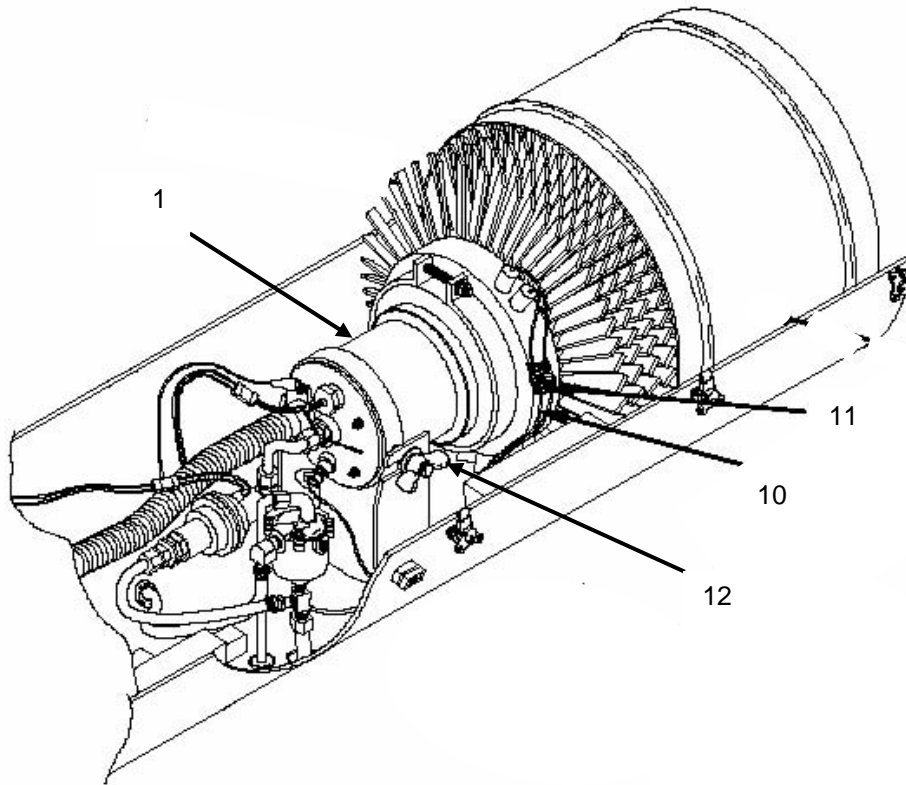

18. Remove the tags and connect the two TEG connectors **(8)** and **(9)**.
19. Remove the tags and connect the glow plug lead **(2)**, flame sensor connector **(3)**, and ground leads **(4)** and **(5)**.
20. Connect the fuel line **(6)**, and combustion air blower duct **(7)** to the burner assembly **(1)**.
21. Replace the upper housing assembly (WP 0023 00).
22. Start the heater and check for proper operation.
23. Run the heater long enough to fully charge battery.

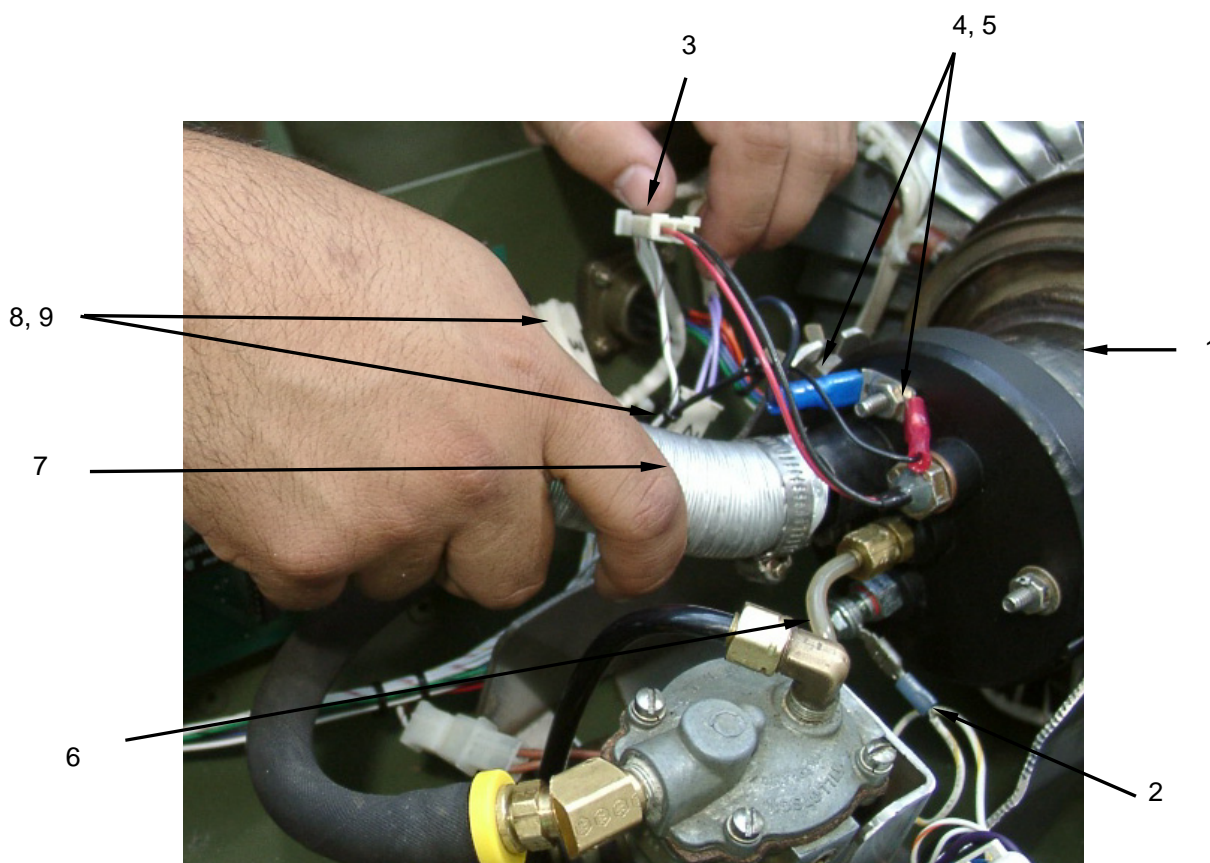

REPLACE

1. To replace the burner assembly, remove the burner as described in the Remove section of this work package.
2. Mount the new burner assembly **(1)** on burner bracket **(2)** by sliding screws **(3)** into burner bracket slots **(4)**. Ensure that the flame sensor is positioned at the top.
3. Ensure that the fiberglass rope is in place in the groove on the front surface of the TEG flange.
4. Ensure that the mantle is in place inside the TEG.
5. Move the burner assembly **(1)** toward the mantle and TEG **(5)** and seat it against and aligned with the TEG. Tighten the two wings nuts **(6)** securely.

6. Install new graphite ribbon seal **(7)** around the TEG flange and the burner flange. Center the graphite ribbon tape so that it equally overlaps both flanges. Overlap the ends of the graphite ribbon tape by approximately 1 to 1 1/2 inches.
7. Install and secure the burner assembly **(2)** to the TEG with the V-clamp with nut **(8)**. Do not rotate the clamp once it is over the graphite tape. Tighten the two nuts securely.
8. Connect fuel line **(13)** to burner assembly **(2)** at fitting **(14)**.
9. Connect combustion air inlet pipe **(9)** to burner assembly **(2)** using hose clamp **(10)**. Tighten clamp securely.
10. Connect the flame sensor connector **(11)** and connect the wire to the glow plug **(12)**.
11. Reconnect ground wires **(15 and 16)**.

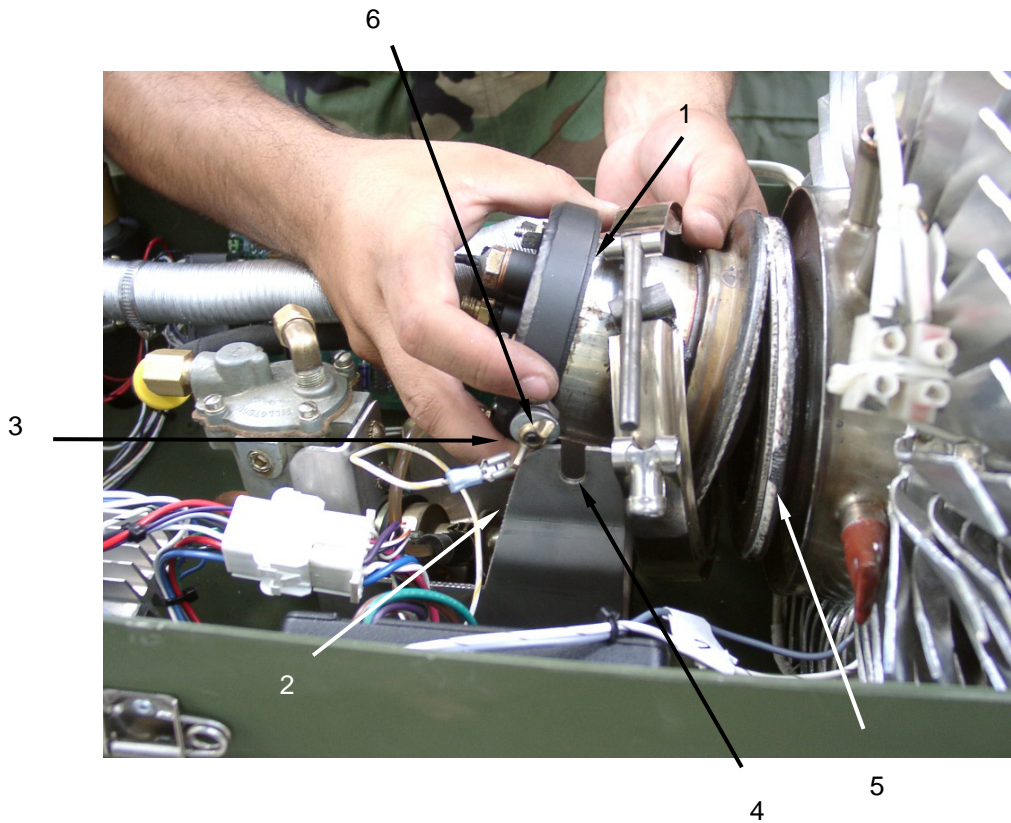

NOTE

The TEG and burner assembly have been removed from the heater for illustrative purposes only. Graphite tape is installed while the TEG and burner assembly are installed in the heater.

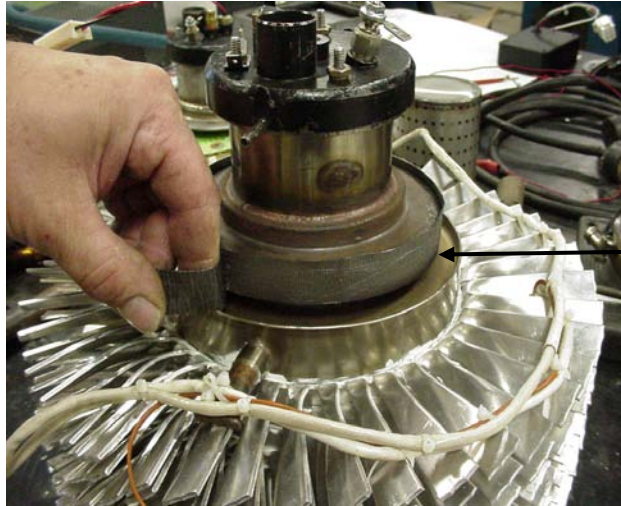

7



8

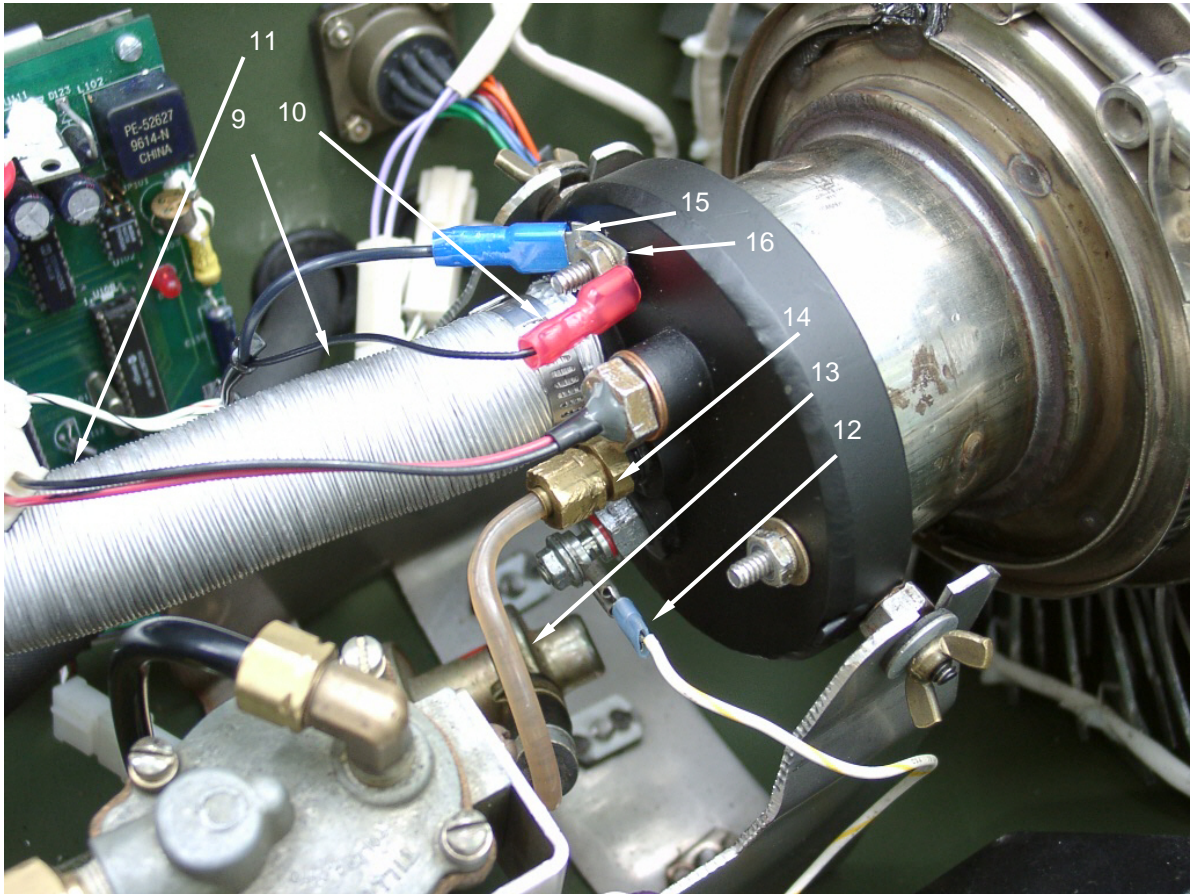

UNIT MAINTENANCE**SPACE HEATER, CONVECTIVE****(NSN 4520-01-431-8927)****THERMOELECTRIC GENERATOR (TEG)
REPAIR, INSPECT, TEST, REPLACE**

INITIAL SETUP**Tools**Tool Kit, General Mechanics
(Item 1, WP 0044 00)**Materials/Parts**Rags, Wiping, Clean (Item 5, WP 0067 00)
Mat, Petroleum Absorbent (Item 15, WP 0067 00)
Wrap, Tie (Item 13, WP 0067 00)
Wrap, Tie (Item 14, WP 0067 00)
Adhesive (Item 1, WP 0067 00)
Marker, Tube Type (Item 16, WP 0067 00)**Equipment Condition**Heater shut down and all advisory lights off.
(WP 0006 00)
In-tent controller assembly disconnected from heater.
(WP 0006 00)
Fuel supply disconnected. (WP 0006 00)
Upper housing assembly removed. (WP 0030 00).
Burner to TEG flange clamp removed. (WP 0037 00).
Battery disconnected. (WP 0018 00)

REPAIR**Thermoelectric Generator Sensor****CAUTION**

Disconnect battery connector. Before performing any maintenance actions, be sure to disconnect the battery to prevent component failure. Failure to comply may result in damage to electrical components.

1. Place a section of petroleum absorbent mat in the bottom of the lower housing assembly under the burner assembly in order to catch any fuel that may spill. Wipe up any spilled fuel with the mat.
2. Tag and disconnect the glow plug lead **(1)**, flame sensor connector **(2)**, and ground leads **(3)**.
3. Disconnect the fuel line **(4)** and the combustion air blower duct **(5)** from the burner assembly **(6)**.

4. Tag and disconnect the TEG electrical connectors (7).

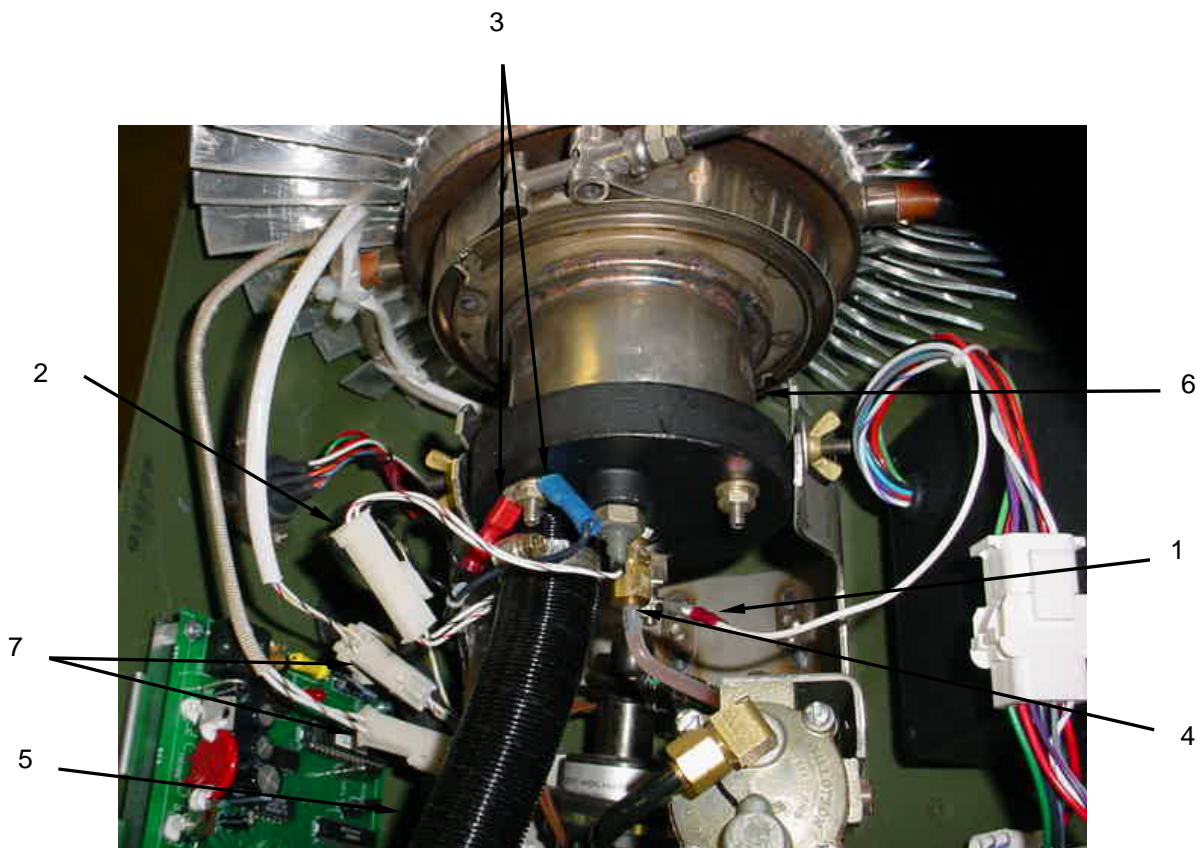

NOTE

Do not loosen the top screws for the wires that enter the interior of the TEG.

5. Tag and disconnect the two wires (8) going into the modular connector (9) on the side of the TEG by loosening the two bottom screws.

CAUTION

Take care not to bend any of the fins on the TEG. Damaging the fins reduces airflow and directly affects the performance of the system. Failure to comply may result in damage to the equipment.

6. Loosen the wing nuts (10) on the side of the burner assembly (6) and lift assembled heat exchanger (11) and TEG (12) and remove from the heater body.
7. Place the heat exchanger (11) and TEG (12) on an appropriate work surface burner assembly (6) end up.

8. Remove the exhaust grommet (13) and set it aside.
9. Remove sheet metal screws (14) and washers (15) from wrap cover (16) and set aside.
10. Carefully remove the wrap cover (16) and set aside.

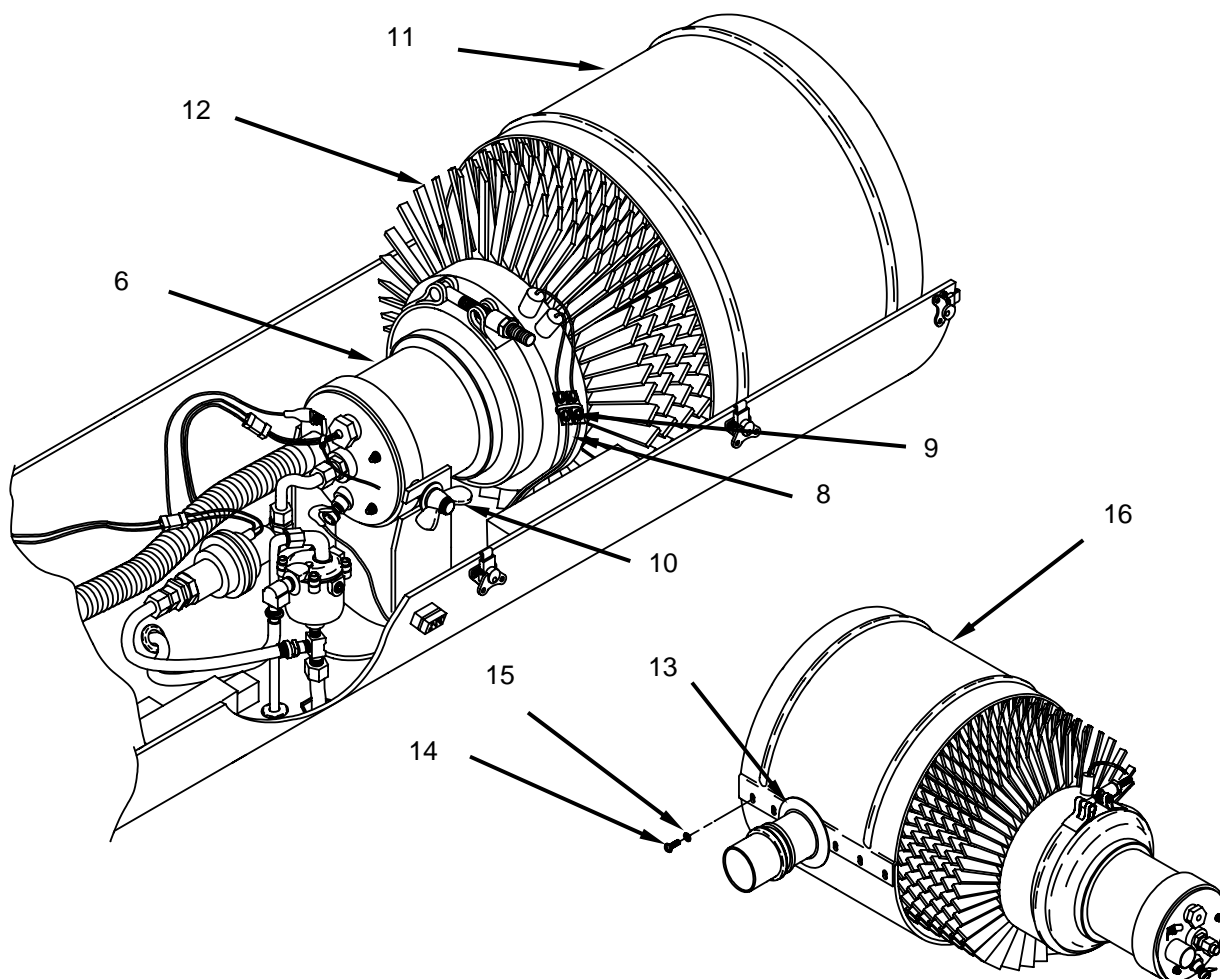

11. Mark the fins (17) with a felt tip pen where the TEG sensor wire (19) and over-heat sensor wire (20) is routed for assembly.

12. Cut the entire tie wrap (18) holding the TEG sensor (19) and over-heat sensor (20) to the TEG fins (17).
13. Gently pull back the TEG fin (17) to expose the TEG sensor (19) in the sensor pocket (21).

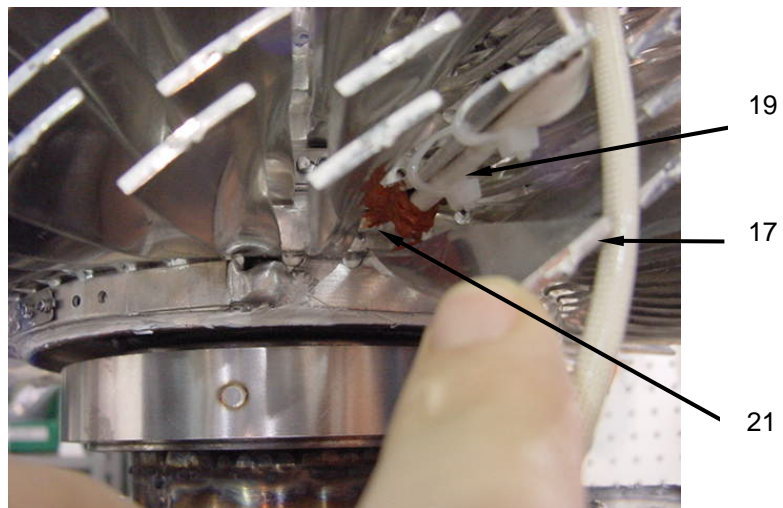
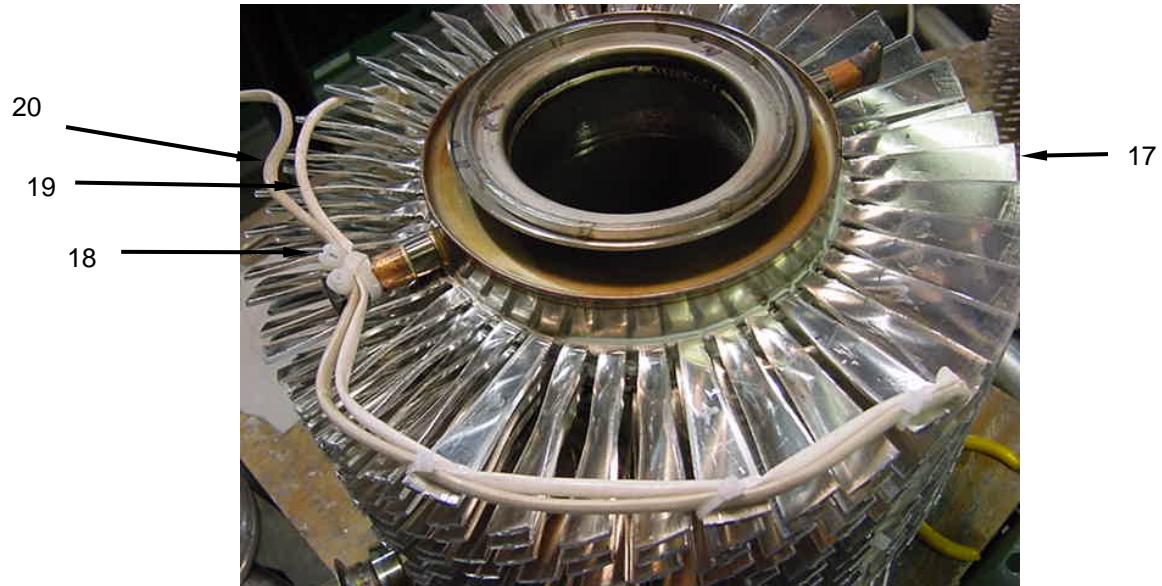

NOTE

The TEG sensor is sealed with an adhesive.

14. Remove the sealant and pull out the TEG sensor **(19)** from the sensor pocket **(21)**.
15. Clean any remaining sealant from the sensor pocket **(21)**.

NOTE

In the illustration, the last row of cooling fins has been removed for the sake of clarity. Do not remove this for repair.

16. Place the exposed portion of the new sensor **(19)** inside the sensor pocket **(21)**.
17. Attach the sensor to the fin with two tie wraps **(22)** as shown.
18. Trim the excess from the tie wraps **(22)** after tightening.

**WARNING**

Wear protective clothing when applying the sealant. The sealant can cause irritation to the skin. Failure to comply may result in injury to personnel.

CAUTION

Do not get the sealant inside the sensor pocket. The sealant seals the sensor inside the sensor pocket to keep air from affecting it. The sensor will not be able to read the temperature if it's covered in sealant. Failure to comply may result in damage to the equipment.

NOTE

Each manufacturer may have different cure time requirements. Follow the curing instructions for the sealant.

19. Apply high temp sealant on the outside of the sensor pocket **(21)** and on the outside of the new sensor **(19)** above the sensor pocket.



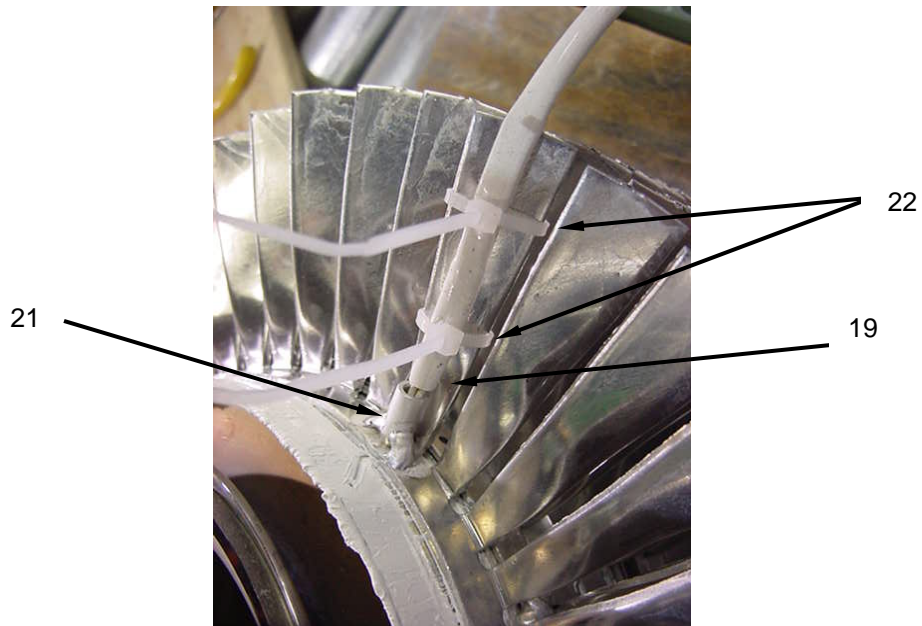
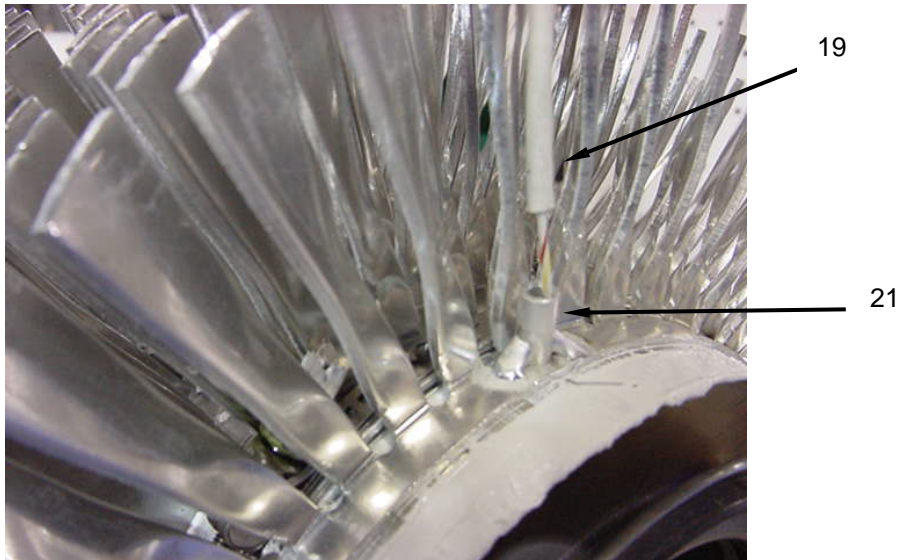

20. Bend the fin back into place.

CAUTION

Do not over tighten tie wraps. The edge of the fin may cut or crush the wire and the insulation. Failure to comply may result in damage to the equipment.

21. Route the TEG and over-heat sensor wires **(20)** through the fins and secure with the small tie wraps **(23)**.

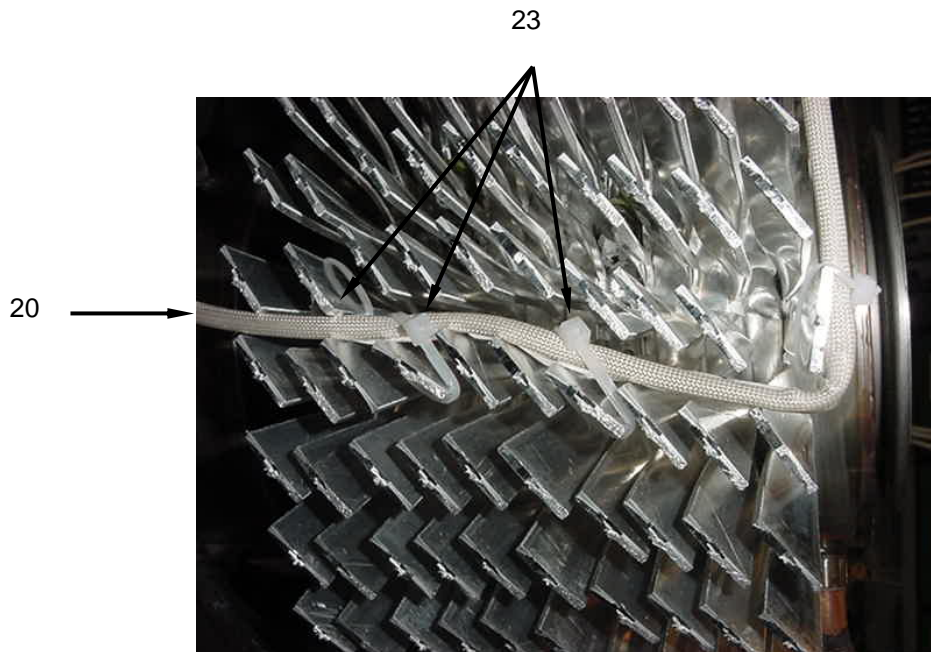

22. Route the TEG and over-heat sensor wires **(20)** over fins and secure with the small tie wraps **(23)** as shown.

CAUTION

The edge of the fin may cut or crush the wire and the insulation. Failure to comply may result in damage to the equipment.

NOTE

Burner has been removed in this picture for clarity. The burner and heat exchanger do not need to be removed for this procedure.

23. Use the larger tie wrap **(24)** and secure the wires to the TEG stub **(25)** in an "X" pattern. Trim the excess.

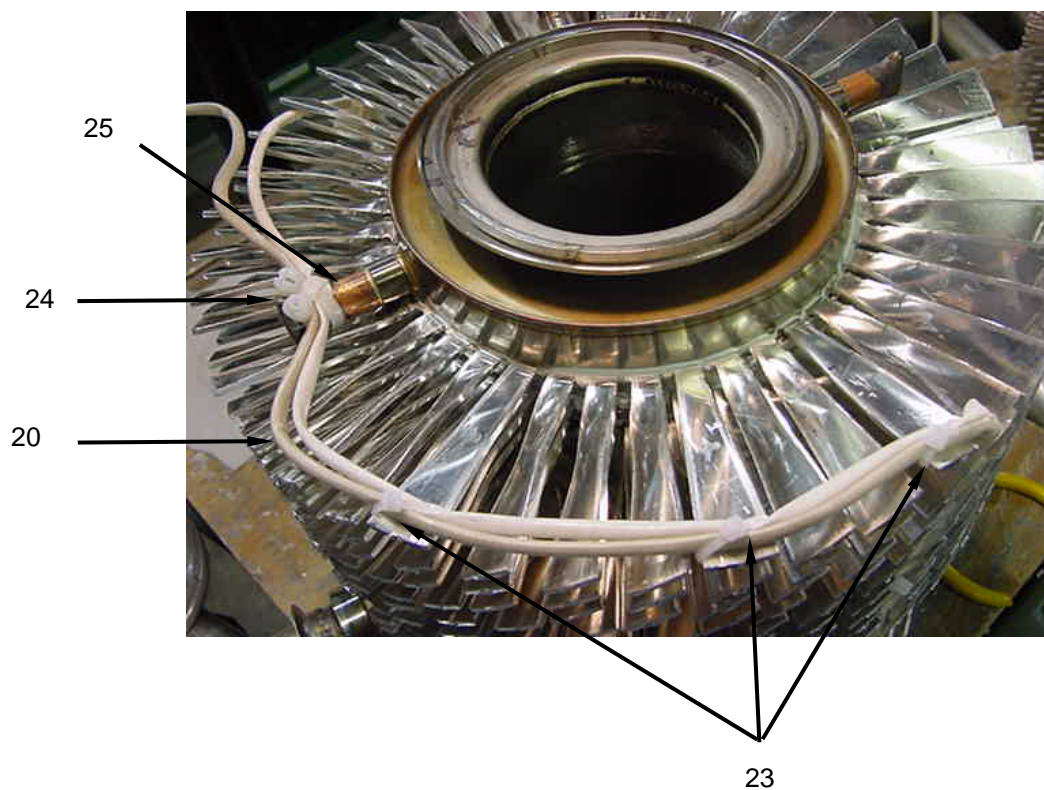

24. Align the cutouts in the wrap cover **(16)** and position around the heat exchanger **(11)**.
25. Install the sheet metal screws **(14)** and washers **(15)**. Tighten securely.
26. Install the exhaust grommet **(13)** over the combustion exhaust outlet.

27. Place the assembled heat exchanger (11) and TEG (12) into the heater and align the combustion exhaust outlet and exhaust grommet (13) with the exhaust cutout (19) in the lower housing.
28. Tighten the wing nuts (10) on the side of the burner assembly (6).
29. Remove tag and connect the wires (8) to the TEG cooling fin modular connector (9).

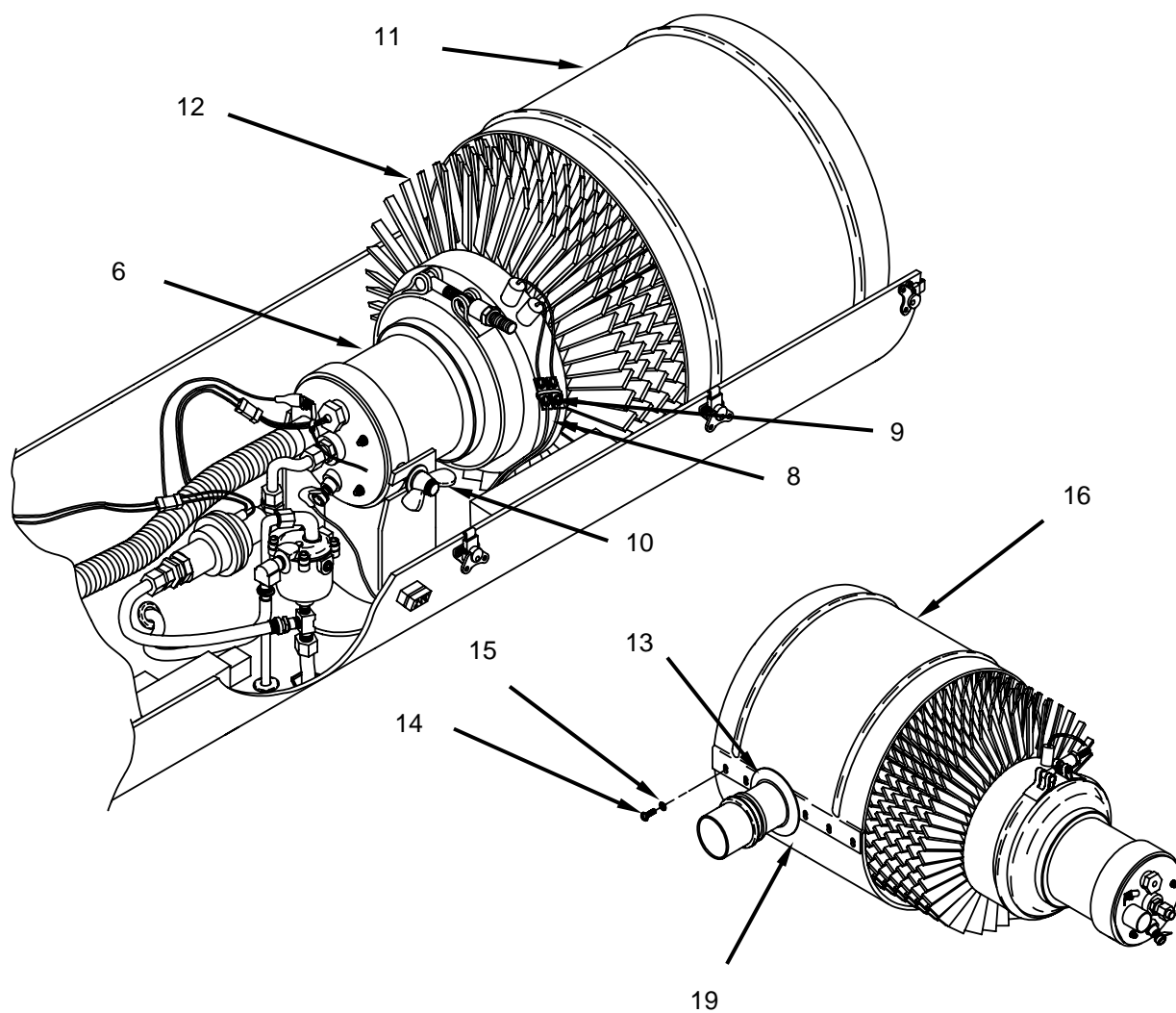

30. Remove tag and connect two TEG connectors (7).
31. Remove tag, connect the glow plug lead (1), flame sensor connector (2), and ground leads (3).
32. Connect the fuel line (4) and combustion air blower duct (5) to the burner assembly (6).

NOTE

Each manufacturer may have different sealant cure time requirements. Follow the curing instructions for the sealant.

33. Install the upper housing assembly (WP 0030 00).
34. Start and operate the heater. Check for proper operation.
35. Run heater long enough to fully charge battery.

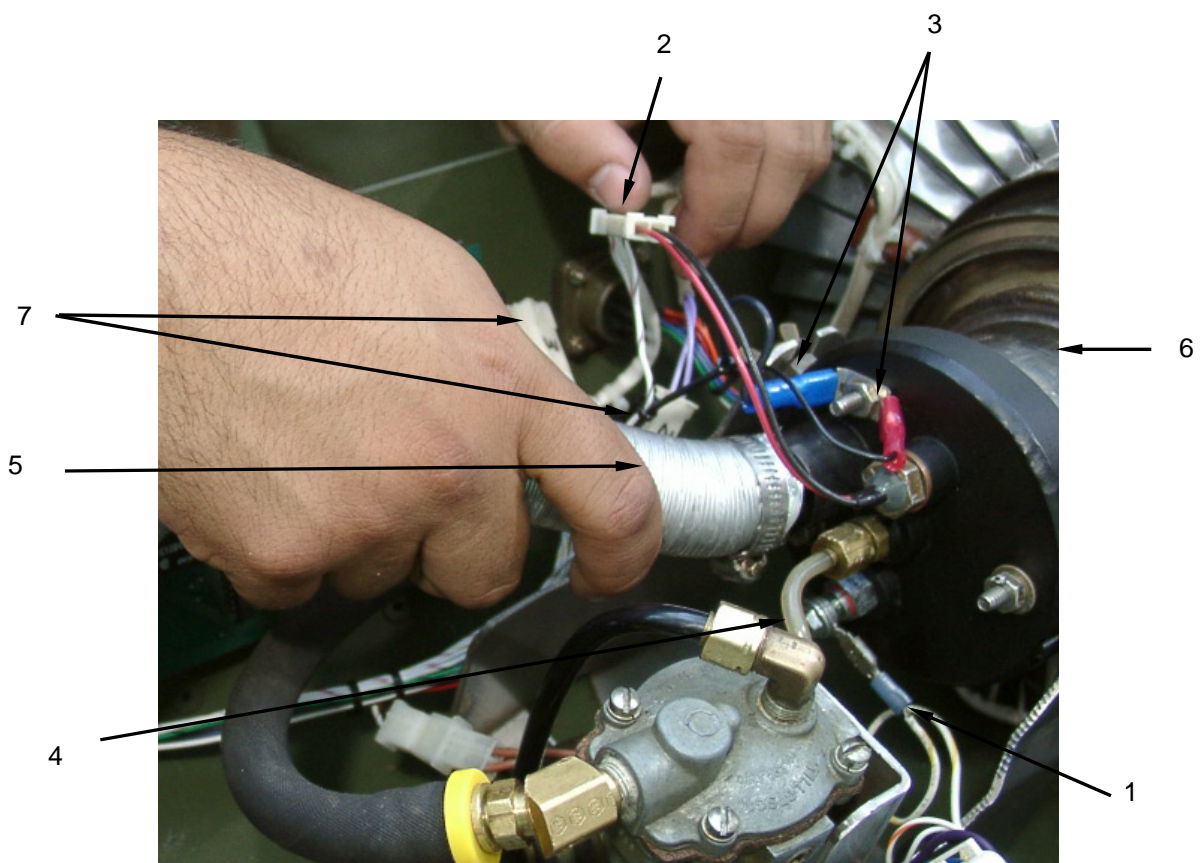

INSPECT

1. Check flanges **(1, 2, and 3)** for bends, breaks, and corrosion.
2. Inspect flange clamp **(4)** for distortion as well as stripped and otherwise damaged threads. Discard clamp if not fully functional.
3. Ensure that the fiberglass ropes **(5)** are positioned in the grooves of the TEG flange and that they are not frayed or damaged in any way.

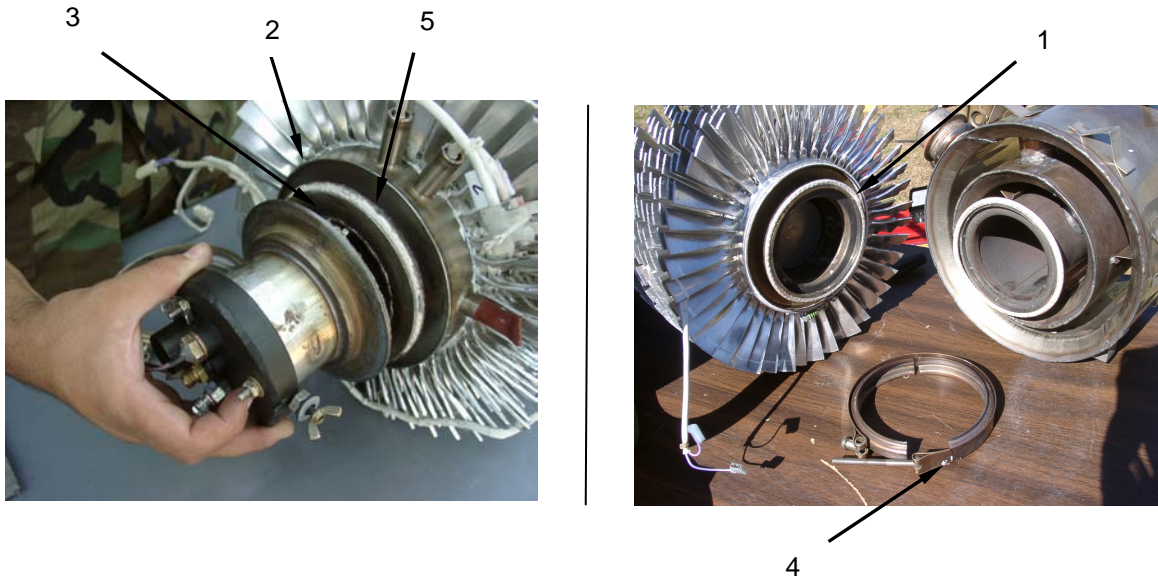
**TEST**

1. If necessary, set the multi-meter to measure resistance in the 10-Ohm range.
2. Place probe No. 1 in contact with the gray wire on the TEG and probe No.2 in contact with the white/gray wire on the TEG. The meter should read between 1 and 5 Ohms. It should not read 0 (zero) Ohms or open.
3. Replace TEG if short or open is indicated.

REPLACE**Thermoelectric Generator**

1. To install a new TEG **(1)**, install fiberglass rope **(2)** in flange grooves on both ends of TEG.
2. While positioning the combustion exhaust outlet **(3)** of the heat exchanger at the 9 o'clock position, position the two input wires **(4)** exiting the TEG at the 1 o'clock position.
3. Align the flanges **(5)** of the TEG **(1)** and heat exchanger **(6)**.
4. Install new graphite ribbon tape **(7)** around the outside of the TEG and heater exchanger flanges **(8)**. Be sure to overlap the tape by approximately 2 to 3 inches.
5. Install flange clamp **(9)** over flanges **(5)** taking care to position the top of the clamp so that it is aligned just to the left of the two input wires **(4)** exiting the TEG. Tighten the clamp securely.
6. Connect the two electrical connectors **(10)** of the thermostat-reset switch **(11)**. Remove any tags.
7. Align cutouts in wrap cover **(12)** with the combustion exhaust outlet **(3)** and position around the heat exchanger **(6)**.
8. Ensure that the wrap cover **(12)** is positioned so that the thermostat-reset switch **(11)** will be accessible through the hole in the lower housing assembly.
9. While holding the wrap cover **(12)** securely in position, install sheet metal screws **(13)** and washers **(14)**. Tighten all screws securely.
10. Install exhaust grommet **(15)** over combustion exhaust outlet **(3)**.
11. Install the burner assembly **(16)** in position on the TEG flange taking care to align the flame sensor **(17)** of the burner assembly with the two input wires **(4)** of the TEG.

NOTE

When properly positioned, the two wing nuts **(18)** on the side of the burner assembly will be aligned with the combustion exhaust outlet **(3)** of the heat exchanger **(6)**.

NOTE

Do not rotate clamp after installing new graphite ribbon tape.

12. Install new graphite ribbon tape **(7)** around the burner assembly **(16)** and TEG flanges. Be sure to overlap the tape two to three inches.

13. Install flange clamp **(9)** over burner assembly and TEG flanges taking care to position the top of the clamp just to the left of the two input wires **(4)** exiting the TEG.
14. Tighten the flange clamp **(9)** securely.
15. Place the assembled heat exchanger, TEG, and burner assembly into the heater body and align the combustion exhaust outlet **(3)** and grommet with the exhaust cutout **(19)** in the lower housing.
16. Engage the groove in the grommet with the cutout **(19)** in the lower housing assembly.
17. Tighten wing nuts **(18)** on side of burner assembly **(16)**.
18. Remove tag and connect wires **(20)** to TEG cooling fin temperature sensor modular connector **(21)**.
19. Remove tag and connect two TEG connectors **(22)**.
20. Remove tag connect the glow plug wire **(23)**, flame sensor connector **(24)**, ground wires **(25)**, fuel line **(26)**, and combustion air blower duct **(27)** to the burner assembly **(16)**.

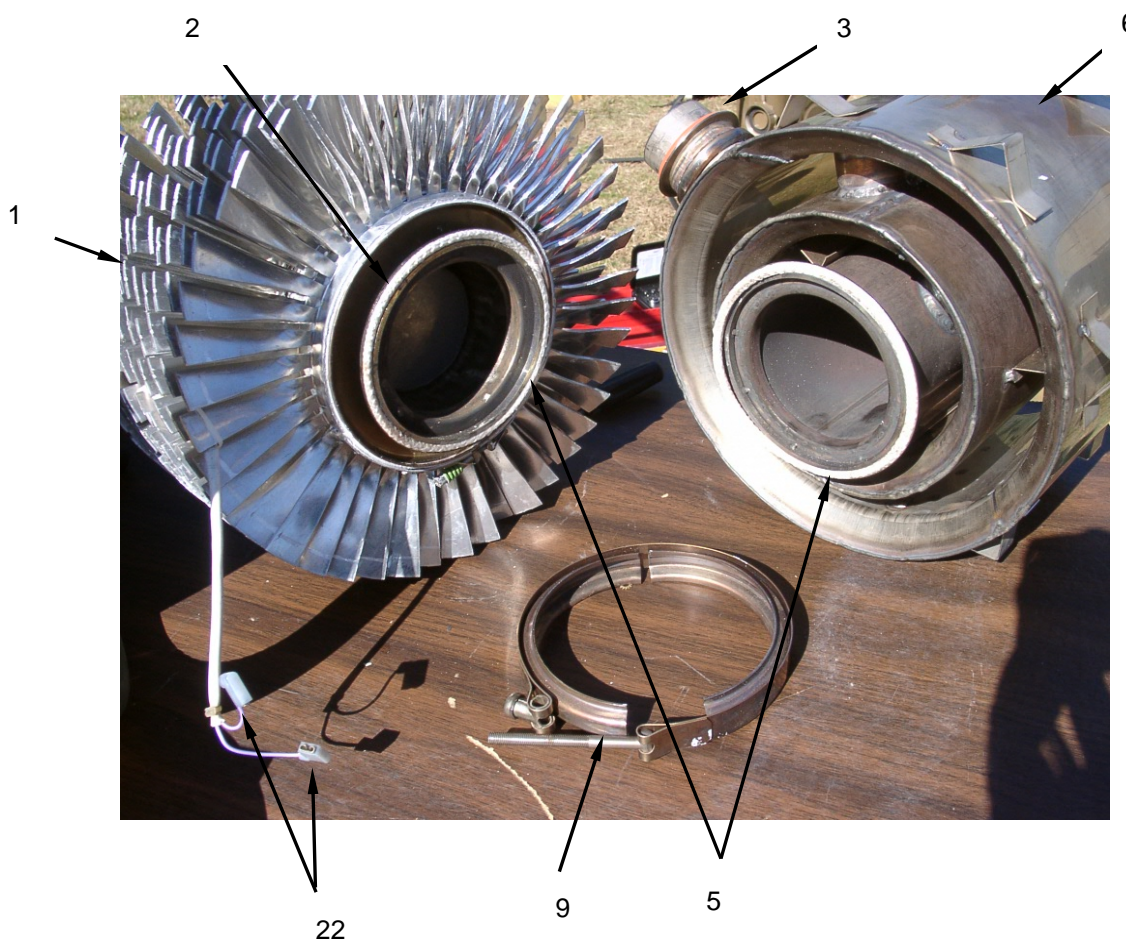

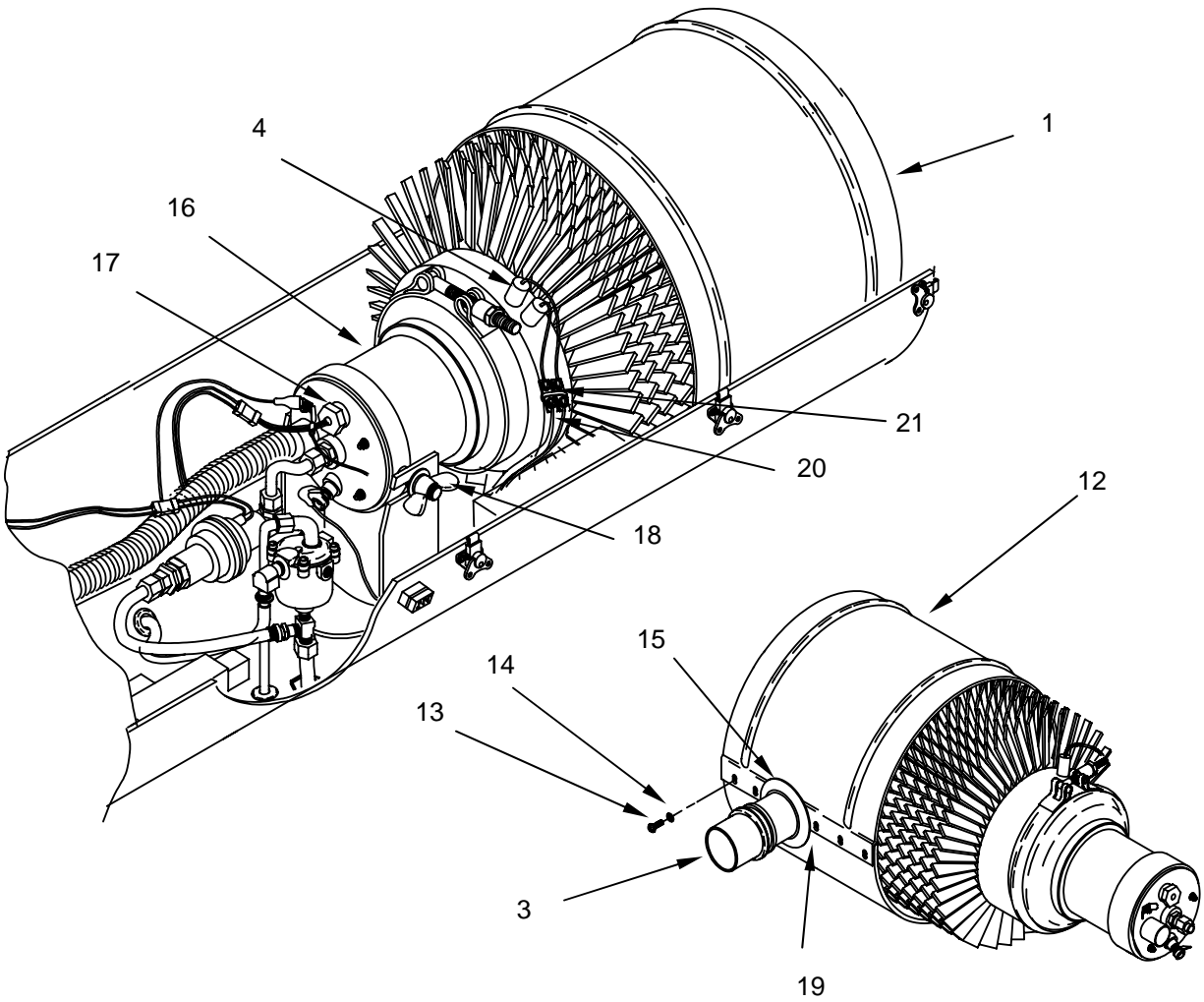
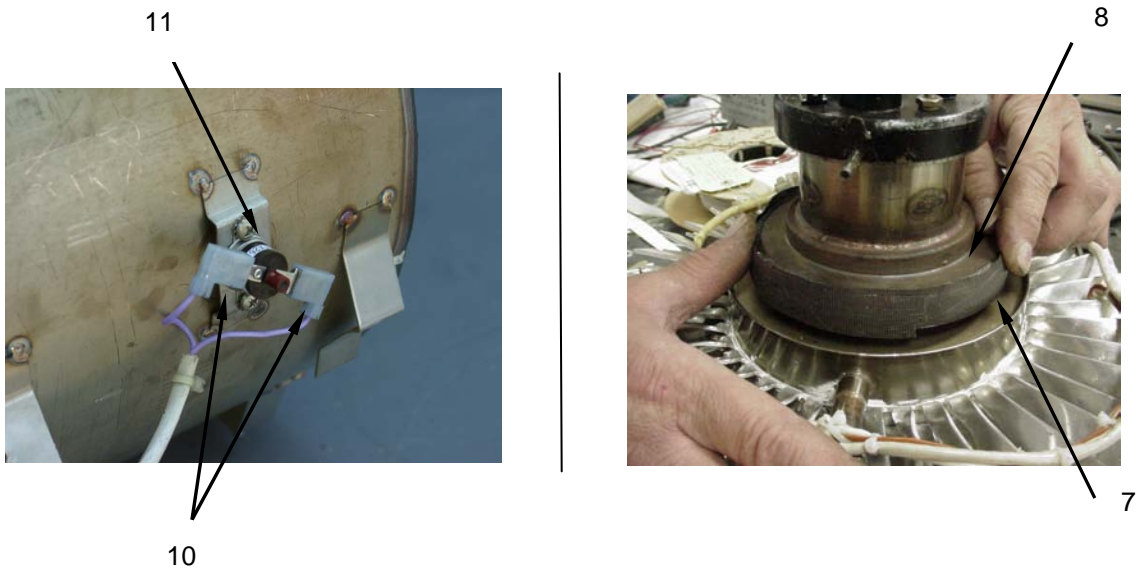

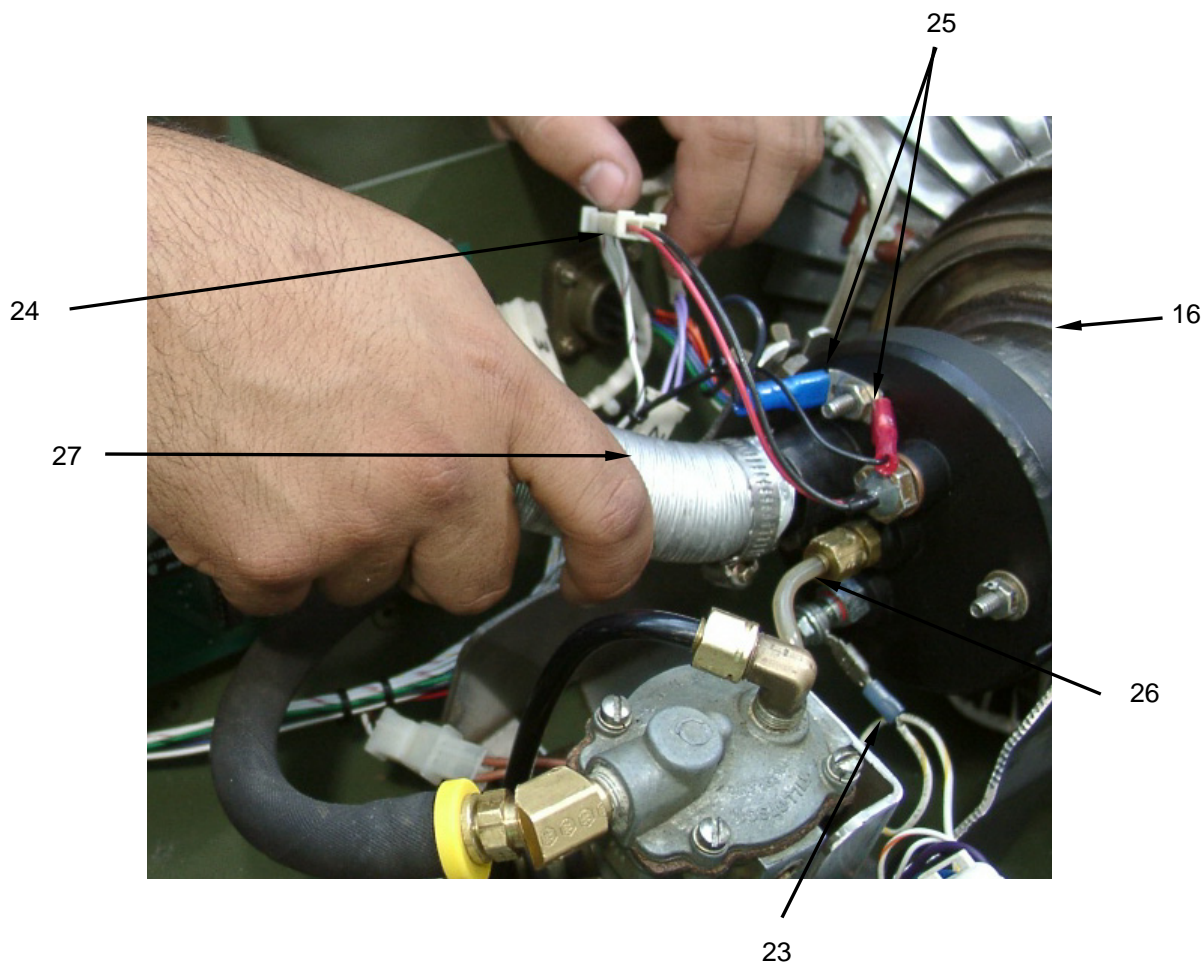

END OF WORK PACKAGE

UNIT MAINTENANCE**SPACE HEATER, CONVECTIVE****(NSN 4520-01-431-8927)****HEAT EXCHANGER
REMOVE, INSPECT, TEST, REPLACE****INITIAL SETUP****Tools**

Tool Kit, General Mechanics (Item 1, WP 0044 00)

Materials/Parts

Rags, Wiping, Clean (Item 5, WP 0067 00)

Mat, petroleum absorbent (Item 15, WP 0067 00)

Equipment Condition

Heater shut down and all advisory lights off. (WP 0006 00)

In-tent controller assembly disconnected from heater. (WP 0006 00)

Fuel source disconnected. (WP 0006 00)

Upper housing assembly removed. (WP 0030 00)

Burner to TEG flange clamp removed. (WP 0037 00)

Battery disconnected. (WP 0018 00)

CAUTION

Disconnect battery connector. Before performing any maintenance actions, be sure to disconnect the battery to prevent component failure. Failure to comply may result in damage to electrical components.

REMOVE

1. Place a section of petroleum absorbent mat in the bottom of the lower housing assembly under the burner assembly in order to catch any fuel that may spill. Wipe up any spilled fuel with a rag.
2. Tag and disconnect the glow plug wire **(1)**, flame sensor connector **(2)**, ground wires **(3 and 4)**, fuel line **(5)**, and combustion air blower duct **(6)** from the burner assembly **(7)**.
3. Tag and disconnect TEG electrical connectors **(8 and 9)**.
4. Tag and disconnect the two leads **(10)** going to the modular connector **(11)** for the TEG cooling fin temperature sensor.
5. Loosen wing nuts on side of burner assembly **(7)** and lift assembled heat exchanger **(12)**, TEG **(13)** and burner assembly **(7)** from heater. Place on an appropriate work surface.

6. Remove exhaust grommet (14).
7. Remove sheet metal screws (15) and washers (16) from wrap cover (17).
8. Remove wrap cover (17) and set aside.
9. Tag and disconnect the connectors (18) for the manual reset thermostat (19).
10. Loosen and remove flange clamp (21) between the heat exchanger (12) and the TEG (13).
11. Separate TEG (13) and heat exchanger (12).
12. Remove and discard all pieces of old graphite ribbon tape that may adhere to the inside surface of flange clamp (21) and to the outside of the TEG and heat exchanger flanges.

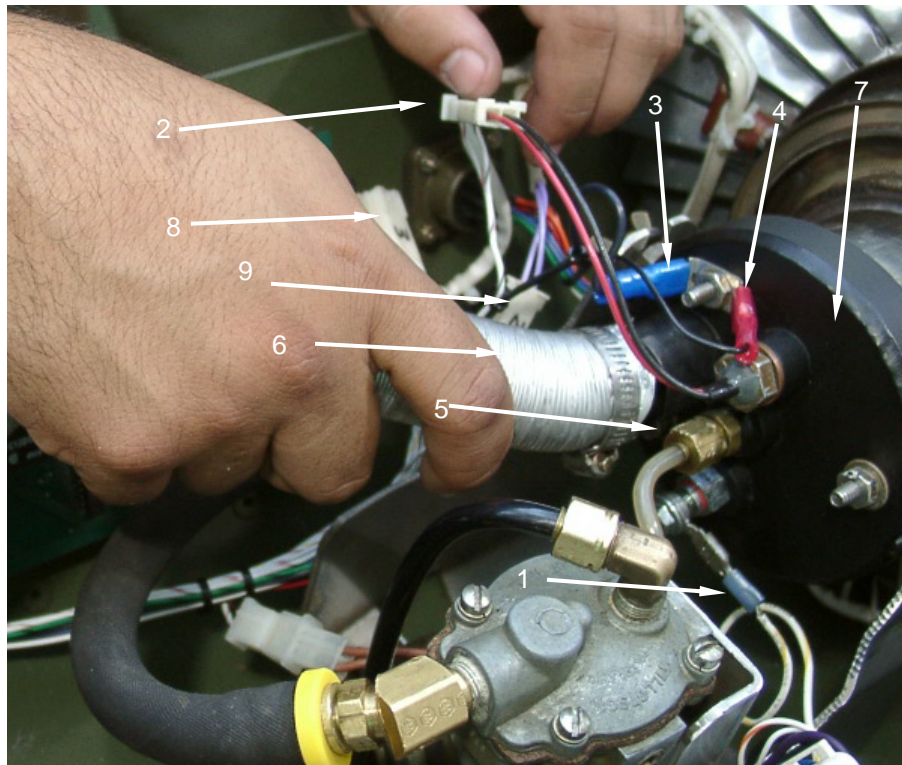

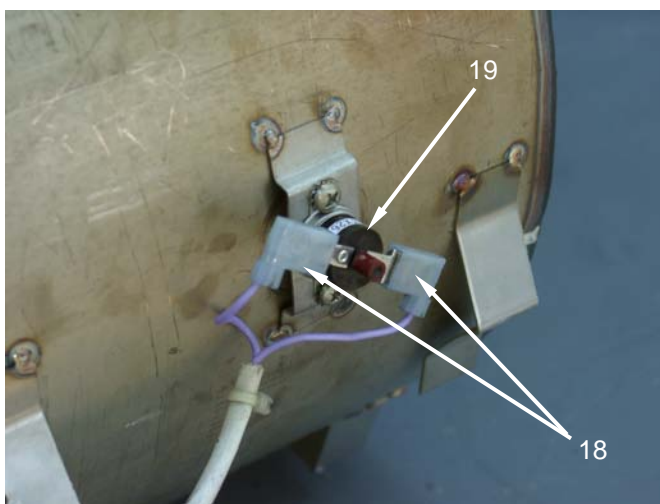
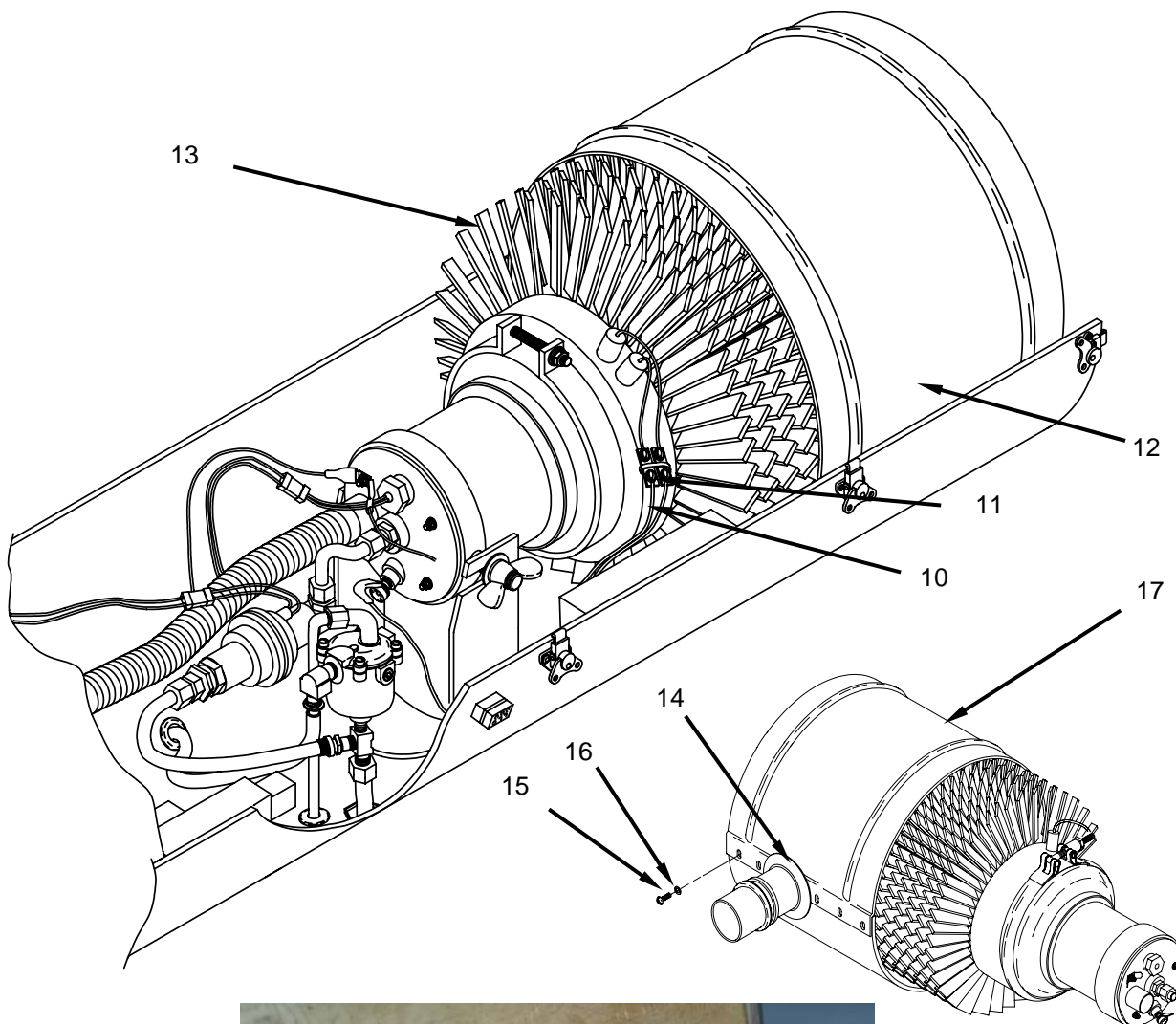

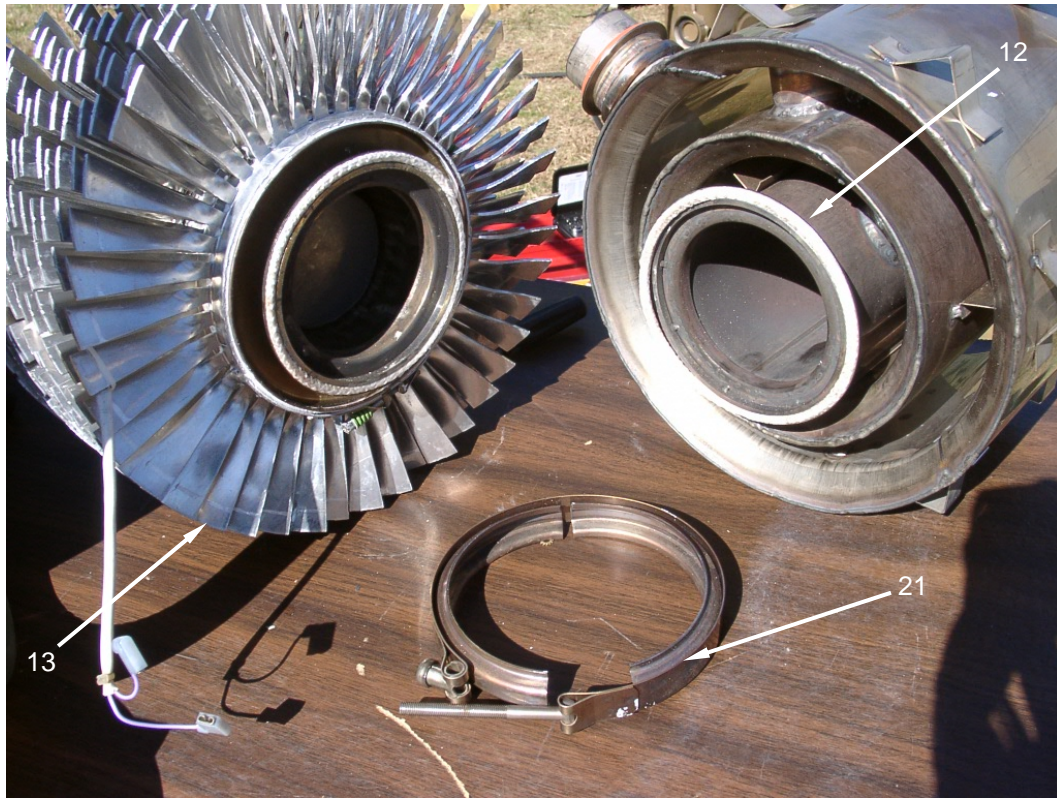

SERVICE

Using rags and alcohol clean the exterior of all accessible features of the heat exchanger assembly (1).



INSPECT

1. Using a flashlight or, if available, a 5X or 10X magnifier, inspect all surfaces of the heat exchanger for any indication of cracks or corrosion that penetrate parent metal.
2. All welds must be inspected thoroughly. Typical welded areas are indicated in the accompanying illustration and are represented by (W). A heat exchanger that leaks may present a hazard to personnel within the tent being heated.
3. Minor surface corrosion that does not penetrate the parent metal may be removed with a wire brush.
4. If any indication of cracks is found, replace the heat exchanger assembly.
5. If any corrosion appears to penetrate the parent metal, replace the heat exchanger assembly.

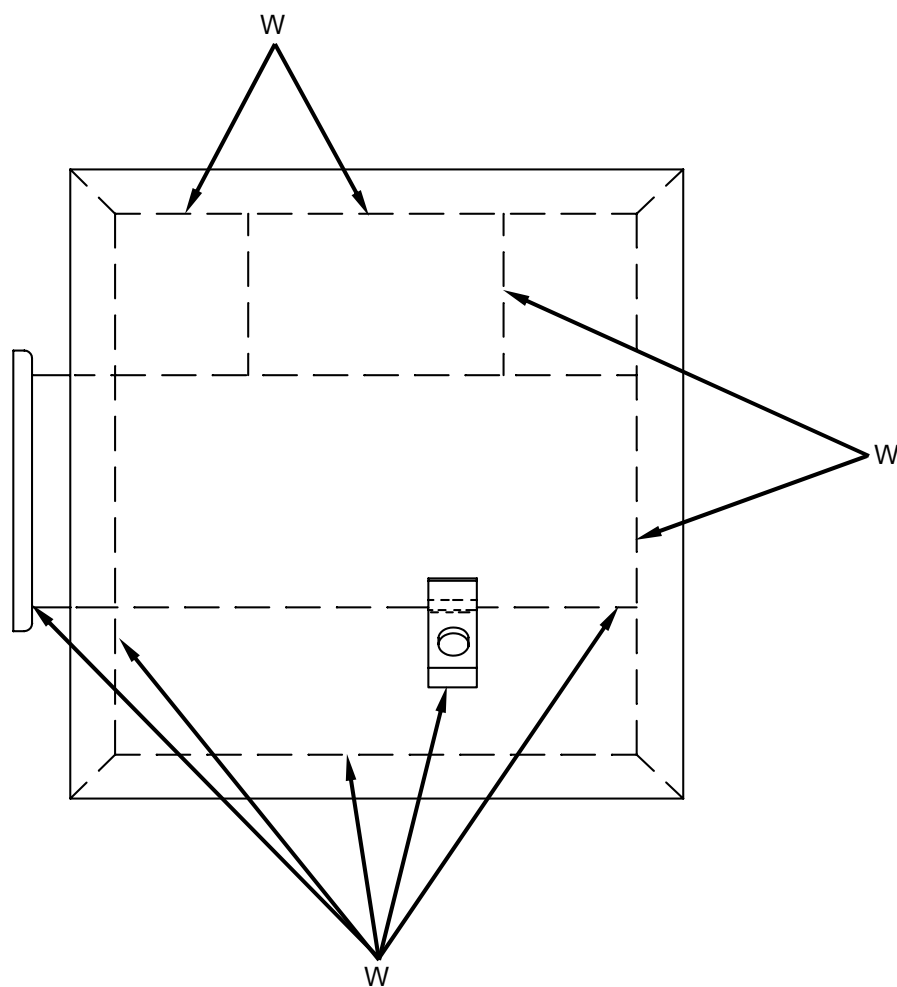

REPLACE

1. To install a new heat exchanger **(1)**, install fiberglass rope **(5)** in the groove of the heater changer flange.
2. Align the flanges **(3)** of the TEG **(4)** and heat exchanger **(1)** and press the TEG and heat exchanger together. Note that the combustion exhaust outlet on the side of the heat exchanger should be at the 9 o'clock position while the TEG input wires are positioned at the 1 o'clock position.
3. Install graphite ribbon seal **(6)** on the outside of the two flanges **(7)**. Be sure to overlap the ends of the tape approximately 2 to 3 inches.
4. Install flange clamp **(7)** over flanges **(3)** so that the top of the clamp is at the 12 o'clock position. Do not rotate the clamp after installing over the graphite ribbon tape. Tighten the clamp securely.
5. Remove tag and install thermostat reset switch **(8)** and connect electrical connectors **(9)**.
6. Align cutouts in wrap cover **(11)** and position around the heat exchanger **(2)**.
7. Install sheet metal screws **(12)** and washers **(13)**. Tighten securely.
8. Install grommet **(14)** over combustion exhaust outlet.
9. Place assembled heat exchanger, TEG, and burner assembly into heater and align combustion exhaust outlet and grommet with exhaust cutout **(15)** in lower housing.
10. Tighten wing nuts **(16)** on side of burner assembly **(17)**.
11. Install exhaust o-ring **(18)**.
12. Remove tag and connect wires **(19)** to TEG cooling fin temperature sensor modular connector **(20)**.
13. Remove tags and connect two TEG connectors **(21 and 22)**.
14. Remove tags and connect the glow plug wire **(23)**, flame sensor connector **(24)**, ground wires **(25 and 26)**, fuel line **(27)**, and combustion air blower duct **(28)** to the burner assembly **(17)**.

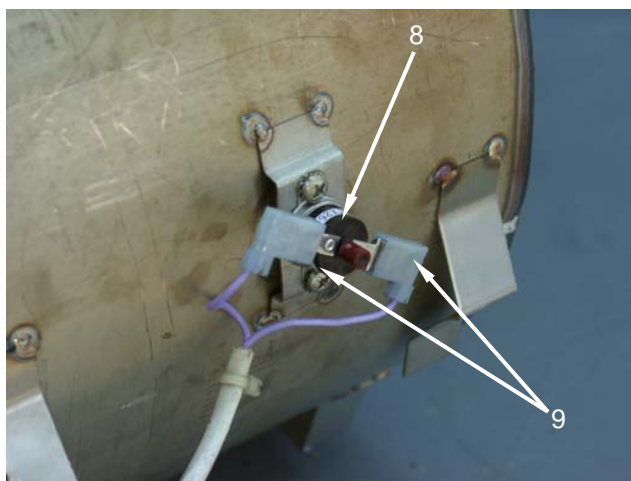
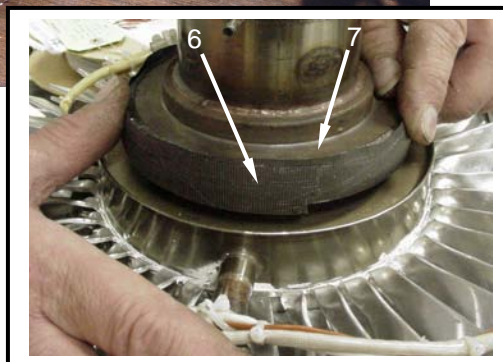

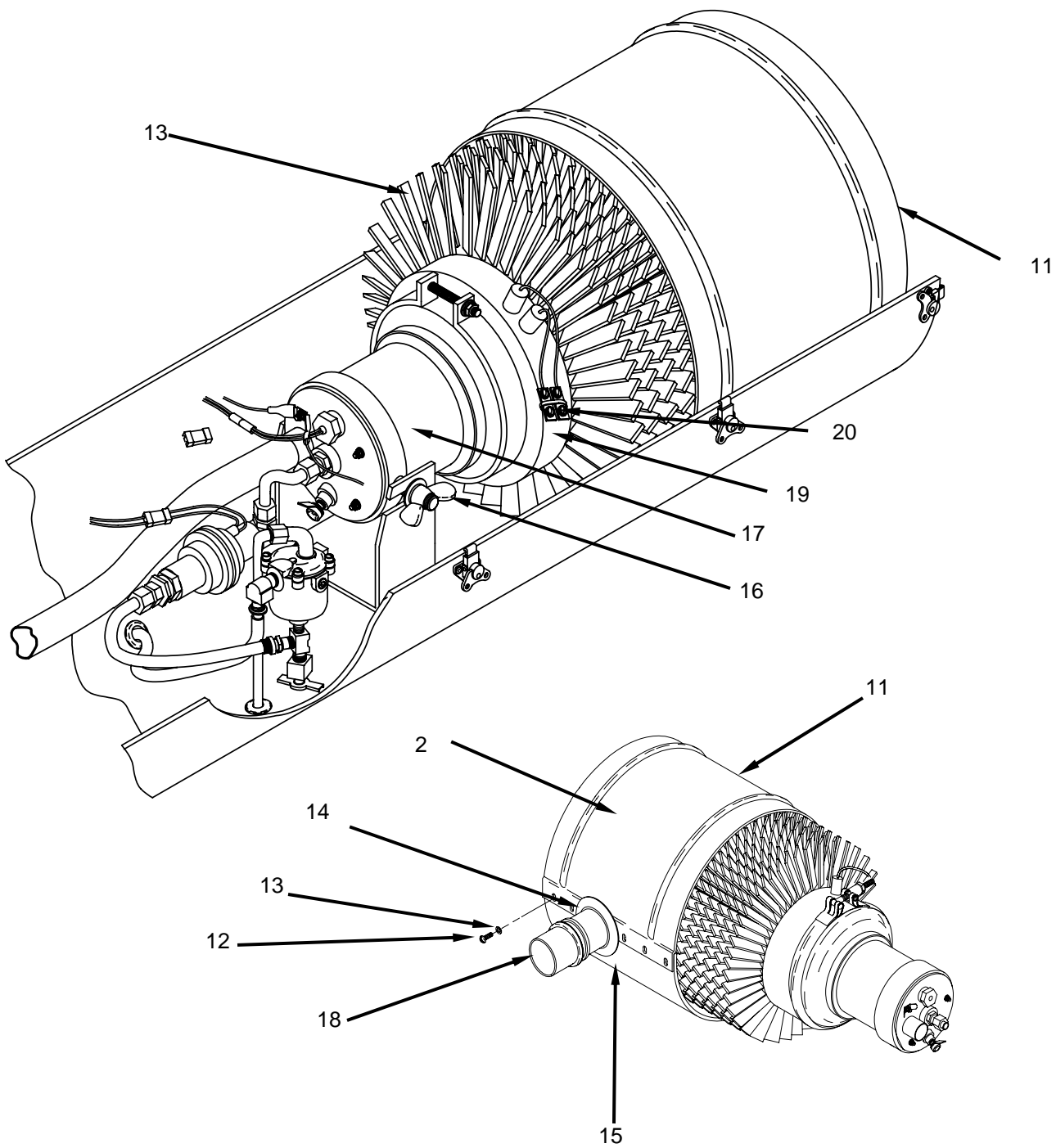

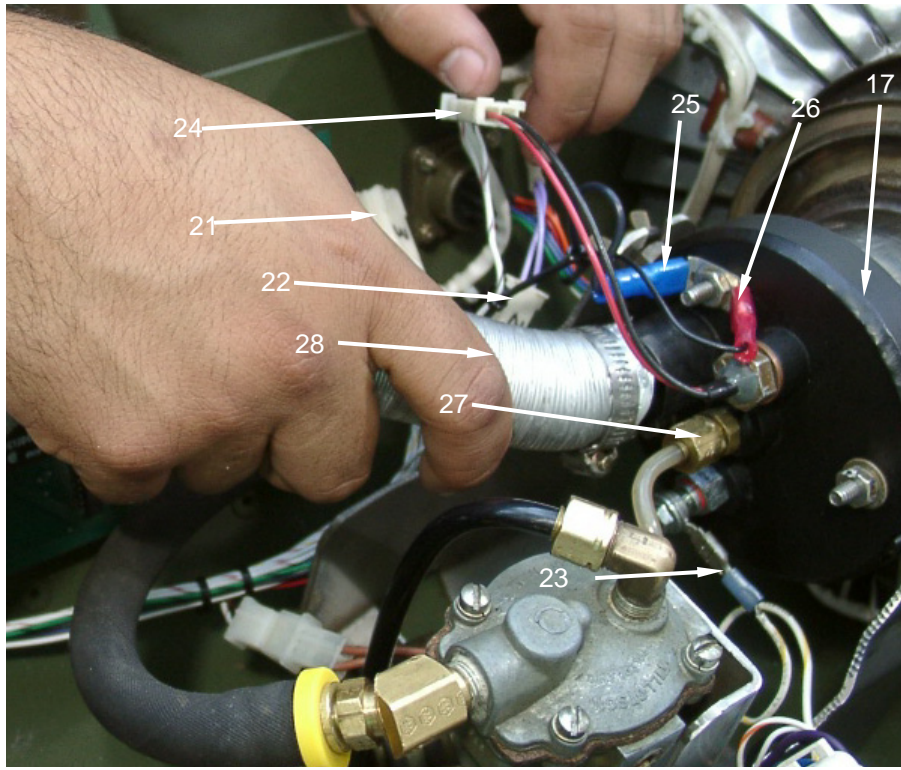

END OF WORK PACKAGE

UNIT MAINTENANCE
SPACE HEATER, CONVECTIVE
(NSN 4520-01-431-8927)
LOWER HOUSING ASSEMBLY
SERVICE

INITIAL SETUPToolsMaterials/Parts

Silicone lubricant (Item 4, WP 0067 00)

Equipment Condition

Heater shut down and all advisory lights off. (WP 0006 00)

SERVICE

Lubricate slide portion **(1)** and pivot **(2)** of adjusting handle **(3)** with silicone lubricant.

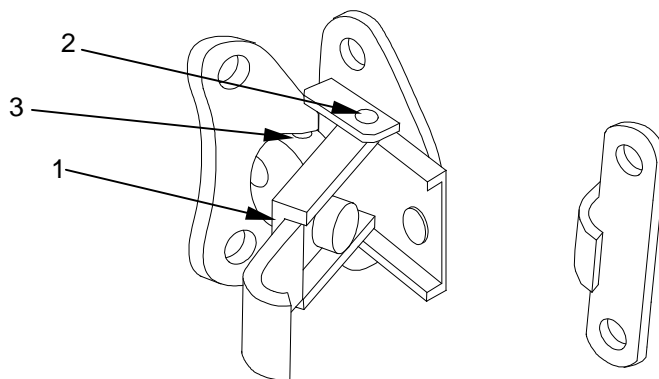
**END OF WORK PACKAGE**

THIS PAGE INTENTIONALLY LEFT BLANK

UNIT MAINTENANCE**SPACE HEATER, CONVECTIVE****(NSN 4520-01-431-8927)****RETURN AND SUPPLY DUCTS WITH DEBRIS GRILLS
INSPECT, REMOVE, REPAIR**

INITIAL SETUP**Tools****Personnel Required**

One

Materials/Parts

Tape, Duct (Item 14, WP 0067 00)

Equipment Condition

Heater shut down and all advisory lights off. (WP 0006 00)

NOTE

The following procedures apply to both the return and/or supply ducts and debris grills.

INSPECT

1. Inspect the return and supply ducts **(1)** for cuts, abrasions, or other damage that would permit air to enter or exit the side walls of the ducts. Repair any rips or cuts in the duct before using.
2. Inspect the debris grills **(2)** for dents or other damage that would impair the free flow of air into or out of the duct. Replace any debris grills that are damaged.

REMOVE

1. To remove the return or supply duct **(1)** from the heater, release the strap **(3)** that secures the return or supply duct to the duct adapters **(4)** at the inlet or outlet end of the heater.
2. To remove the duct **(1)** from the tent duct tunnel **(5)**, untie the strap **(6)** that secures the duct inside the tent duct tunnel and pull out.

REPAIR

1. To repair rips, tears, or cuts in the fabric covering of the duct, cover with at least two layers of duct or similar tape, overlapping the edges of the cut or tear by at least two inches.
2. If damage to the duct is excessive and it is not practical to repair with tape, the duct should be replaced.



END OF WORK PACKAGE

UNIT MAINTENANCE
SPACE HEATER, CONVECTIVE
(NSN 4520-01-431-8927)

PREPARATION FOR STORAGE OR SHIPMENT

REMOVAL FROM SERVICE

To break the system down in preparation for movement, ensure that the heater is off, the blower fans stopped, and all advisory lights off.

1. Remove the fuel can from the fuel can stand assembly. Set the fuel can down in the upright position.



WARNING

Drain fuel into a container and dispose of fuel in a safe manner.

2. Place a mat or tray containing petroleum absorbent material under the heater fuel quick disconnect to collect the small amount of fuel that may drain from heater and the fuel hose.
3. Disconnect the in-tent controller cable from the control connector on the front of the heater.
4. Disconnect the battery by disengaging the battery pack connector from the connector on the lower housing assembly.
5. Open the fuel drain valve at the base of the heater and drain fuel into a petroleum absorbent tray. Close the fuel drain valve when all fuel has been emptied.
6. Remove the fuel hose from the fuel quick disconnect and lift the hose above the level of fuel can. Allow all fuel to drain back into the fuel can. Install the protective dust cap on the fuel quick disconnect.
7. Coil the fuel hose back to the fuel supply site and disconnect the fuel hose from the gravity feed adapter. Connect the two ends of the fuel hose together to keep dirt or contaminants from entering the fuel connectors.
8. Loosen the gravity feed adapter and remove it from the fuel can. Place the gravity feed adapter on the petroleum absorbent mat and wipe any residual fuel off the gravity feed adapter with the mat prior to storage.
9. Disassemble the fuel can stand by removing the clip, raising the two support arm, and separating the lower legs from the upper portion of the stand. Wrap the straps around the stand and secure.
10. Remove the air outlet duct from the heater by releasing the strap and sliding off the duct adapter.

11. Untie the tent duct tunnel strap and remove the duct from the tent duct tunnel.
12. Secure the tent duct tunnel by closing off with the tie strap.
13. Compress the duct and secure using the interior strap.
14. Remove the air inlet duct from the heater by releasing the strap and sliding off the duct adapter.
15. Untie the tent duct tunnel strap and remove the duct from the tent duct tunnel.
16. Remove the in-tent controller and disconnect the in-tent controller cable. Install the protective caps on the connectors of the in-tent controller and cable.
17. Secure the tent duct tunnel by closing off with the tie strap.
18. Compress the duct and secure using the interior strap.
19. Install the dust covers over the inlet and outlet duct adapters.
20. Stow all components except the heater in the accessory bag.
21. Store and transport the heater in the horizontal position. Do not place it on end.

PRESERVATION

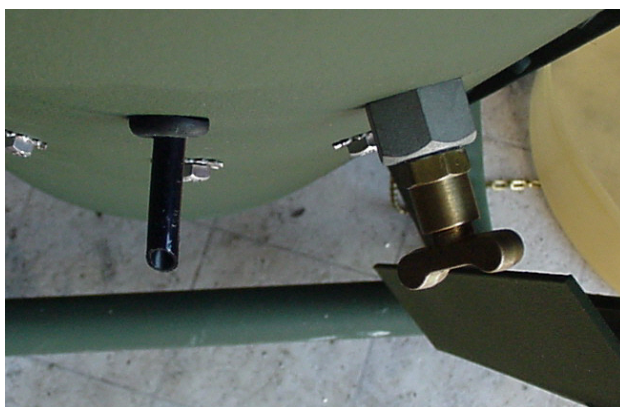

NOTE

If a heater is operated on a fuel other than JP-8 prior to long term storage, any fuel remaining in the heater may solidify in cold temperature, making the heater inoperable.

1. Operate the heater (using JP-8 is required) until the Battery Charged light illuminates.
2. Place a fuel absorbent mat under the fuel drain valve (1).
3. Disconnect the fuel from the heater.

4. Allow the heater to operate until it shuts down and gives a fault code.
5. Drain any residual fuel onto the fuel absorbent mat by opening the fuel drain valve (1).

PACKAGING

1. Place heater assembly into heater storage case if available.
2. Make sure the following items are with the onboard spares and tools: glow plug, flame sensor, battery charger adapter (separate item not included with onboard spares and tools), spare fuses, and wrench.
3. Fold and stow fuel can stand assembly. Wrap hook and pile straps around fuel can stand to secure.
4. Compress the air supply and return ducts and secure with the inside strap.
5. Stow the fuel can stand inside one of the compressed ducts.
6. Stow the in-tent controller assembly and in-tent controller cable assembly inside the duct with the fuel can stand.
7. Drain any residual fuel from the gravity feed adapter and fuel hose assembly into an approved container. Wipe up any spilled fuel. Place gravity feed adapter and hose assembly inside the second compressed duct.
8. Stow the two ducts inside the accessory bag.
9. Stow the technical manual and battery charging adapter between the two ducts inside the accessory bag.
10. Close and secure the accessory bag.

ADMINISTRATIVE STORAGE

1. Placement of equipment in administrative storage should be for short periods of time when a shortage of maintenance effort exists. Items should be in mission readiness within 24 hours or within the time factors as determined by the directing authority. During the storage period, appropriate maintenance records will be kept.
2. Before placing the equipment in administrative storage, current preventive maintenance checks and services should be completed, shortcomings and deficiencies should be corrected, and all Modification Work Orders (MWO) should be applied.
3. Inside storage is preferred for items selected for administrative storage. If inside storage is not available, trucks, vans, conex containers, and other containers may be used.

END OF WORK PACKAGE

TM 10-4520-262-12&P

CHAPTER 6
SUPPORTING INFORMATION
SPACE HEATER, CONVECTIVE

**SPACE HEATER, CONVECTIVE (SHC)
REFERENCES**

SCOPE

This work package lists all forms, field manuals, and technical manuals referenced in this manual.

FORMS

Recommended Changes to Publications and Blank Forms	DA Form 2028
Recommended Changes to Equipment Technical Manuals	DA Form 2028-2
Equipment Inspection and Maintenance Worksheet	DA Form 2404
Product Quality Deficiency Report	SF 368

FIELD MANUALS

Chemical and Biological Contamination Avoidance	FM 3-3
NBC Decontamination	FM 3-5
First Aid	FM 4-25.11

TECHNICAL MANUALS

Destruction of Army Materiel to Prevent Enemy Use	TM 750-244-3
Inspection, Care, and Maintenance of Antifriction Bearings	TM 9-214
Painting Instructions for Army Materiel	TM 43-0139

MISCELLANEOUS

The Army Maintenance Management System (TAMMS) Users Manual	DA PAM 750-8
Functional Users Manual for the Army Maintenance Management System	DA PAM 738-751
Expendable/Durable Items	CTA 50-970
Army Medical Department Expendable/Durable Items	CTA 8-100
Army Logistics Readiness and Sustainability	AR 700-138

UNIT MAINTENANCE
SPACE HEATER, CONVECTIVE
MAINTENANCE ALLOCATION CHART

INTRODUCTION

The Army Maintenance System MAC

This introduction provides a general explanation of all maintenance and repair functions authorized at the two maintenance levels under the Two-Level Maintenance System concept.

The MAC (immediately following the introduction) designates overall authority and responsibility for the performance of maintenance functions on the identified end item or component. The application of the maintenance functions to the end item or component shall be consistent with the capacities and capabilities of the designated maintenance levels, which are shown on the MAC in column (4) as:

Field - includes two columns, Unit maintenance and Direct Support maintenance. The Unit maintenance column is divided again into two more subcolumns, C for Operator or Crew and O for Unit maintenance.

Sustainment – includes two subcolumns, General Support (H) and Depot (D).

The tools and test equipment requirements table (immediately following the MAC) list the tools and test equipment (both special tools and common tool sets) required for each maintenance function as referenced from the MAC.

The remarks table (immediately following the tools and test equipment requirements) contain supplemental instructions and explanatory notes for a particular maintenance function.

Maintenance Functions

Maintenance functions are limited to and defined as follows:

1. Inspect. To determine the serviceability of an item by comparing its physical, mechanical, and/or electrical characteristics with established standards through examination (e.g., by sight, sound, or feel.) This includes scheduled inspection and gagings and evaluation of cannon tubes.
2. Test. To verify serviceability by measuring the mechanical, pneumatic, hydraulic, or electrical characteristics of an item and comparing those characteristics with prescribed standards on a scheduled basis, i.e., load testing of lift devices and hydrostatic testing of pressure hoses.
3. Service. Operations required periodically to keep an item in proper operating condition, e.g., to clean (includes decontaminate, when required), to preserve, to drain, to paint, or to replenish fuel, lubricants, chemical fluids, or gases. This includes scheduled exercising and purging of recoil mechanisms. The following are examples of service functions:
 - a. Unpack. To remove from packing box for service or when required for the performance of maintenance operations.
 - b. Repack. To return item to packing box after service and other maintenance operations.

- c. Clean. To rid the item of contamination.
 - d. Touch up. To spot paint scratched or blistered surfaces.
 - e. Mark. To restore obliterated identification.
4. Adjust. To maintain or regulate, within prescribed limits, by bringing into proper or position, or by setting the operating characteristics to specified parameters.
 5. Align. To adjust specified variable elements of an item to bring about optimum or desired performance
 6. Calibrate. To determine and cause corrections to be made or to be adjusted on instruments of test, measuring, and diagnostic equipment used in precision measurement. Consists of comparisons of two instruments, one of which is a certified standard of known accuracy, to detect and adjust any discrepancy in the accuracy of the instrument being compared.
 7. Remove/Install. To remove and install the same item when required to perform service or other maintenance functions. Install may be the act of emplacing, seating, or fixing into position a spare, repair part, or module (component or assembly) in a manner to allow the proper functioning of an equipment or system.
 8. Paint (Ammunition Only). To prepare and spray color coats of paint so that the ammunition can be identified and protected. The color indicating primary use is applied, preferably, to the entire exterior surface as the background color of the item. Other markings are to be repainted as original so as to retain proper ammunition identification.
 9. Replace. To remove an unserviceable item and install a serviceable counterpart in its place. "Replace" is authorized by the MAC and assigned maintenance level is shown as the third position code of the Source, Maintenance and Recoverability (SMR) code.
 10. Repair. The application of maintenance services, including fault location/troubleshooting, removal/installation, disassembly/assembly procedures and maintenance actions to identify troubles and restore serviceability to an item by correcting specific damage, fault, malfunction, or failure in a part, subassembly, module (component or assembly), end item, or system.

NOTE

The following definitions are applicable to the "repair" maintenance function:

Services. Inspect, test, service, adjust, align, calibrate, and/or replace.

Fault location/troubleshooting. The process of investigating and detecting the cause of equipment malfunctioning; the act of isolating a fault within a system or Unit Under Test (UUT).

Disassembly/assembly. The step-by-step breakdown (taking apart) of a spare/functional group coded item to the level of its least component, that is assigned a SMR code for the level of maintenance under consideration (i.e., identified as maintenance significant).

Actions. Welding, grinding, riveting, straightening, facing, machining, and/or resurfacing.

11. Overhaul. That maintenance effort (service/action) prescribed to restore an item to a completely serviceable/operational condition as required by maintenance standards in appropriate technical publications. Overhaul is normally the highest degree of maintenance performed by the Army. Overhaul does not normally return an item to like new condition.
12. Rebuild. Consists of those services/actions necessary for the restoration of unserviceable equipment to a like new condition in accordance with original manufacturing standards. Rebuild is the highest degree of material maintenance applied to Army equipment. The rebuild operation includes the act of returning to zero those age measurements (e.g., hours/miles) considered in classifying Army equipment/components.

Explanation of Columns in the MAC

Column (1) Group Number. Column (1) lists Functional Group Code (FGC) numbers, the purpose of which is to identify maintenance significant components, assemblies, subassemblies, and modules with the Next Higher Assembly (NHA).

Column (2) Component/Assembly. Column (2) contains the item names of components, assemblies, subassemblies, and modules for which maintenance is authorized.

Column (3) Maintenance Function. Column (3) lists the functions to be performed on the item listed in column (2). (For a detailed explanation of these functions refer to "Maintenance Functions" outlined above).

Column (4) Maintenance Level. Column (4) specifies each level of maintenance authorized to perform each function listed in column (3), by indicating work time required (expressed as manhours in whole hours or decimals) in the appropriate subcolumn. This work time figure represents the active time required to perform that maintenance function at the indicated level of maintenance. If the number or complexity of the tasks within the listed maintenance function varies at different maintenance levels, appropriate work time figures are to be shown for each level. The work time figure represents the average time required to restore an item (assembly, subassembly, component, module, end item, or system) to a serviceable condition under typical field operating conditions. This time includes preparation time (including any necessary disassembly/assembly time), troubleshooting/fault location time, and quality assurance time in addition to the time required to perform the specific tasks identified for the maintenance functions authorized in the MAC. The symbol designations for the various maintenance levels are as follows:

Field:

- C Crew maintenance
- O Service maintenance
- F Field maintenance

Sustainment:

- L Specialized Repair Activity (SRA)
- H Below Depot maintenance
- D Depot maintenance

NOTE

The "L" maintenance level is not included in column (4) of the MAC. Functions to this level of maintenance are identified by work time figure in the "H" column of column (4), and an associated reference code is used in the REMARKS column (6). This code is keyed to the remarks and the SRA complete repair application is explained there.

Column (5) Tools and Equipment Reference Code. Column (5) specifies, by code, those common tool sets (not individual tools), common Test, Measurement and Diagnostic Equipment (TMDE), and special tools, special TMDE, and support special equipment required to perform the designated function. Codes are keyed to the entries in the tools and test equipment table.

Column (6) Remarks Code. When applicable, this column contains a letter code, in alphabetic order, which is keyed to the remarks table entries.

Explanation of Columns in the Tools and Test Equipment Requirements

Column (1) – Tool or Test Equipment Reference Code. The tool or test equipment reference code correlates with a code used in column (5) of the MAC.

Column (2) – Maintenance Level. The lowest level of maintenance authorized to use the tool or test equipment.

Column (3) – Nomenclature. Name or identification of the tool or test equipment.

Column (4) – National Stock Number (NSN). The NSN of the tool or test equipment.

Column (5) – Tool Number. The manufacturer's part number.

Explanation of Columns in Remarks

Column (1) – Remarks Code. The code recorded in column (6) of the MAC.

Column (2) – Remarks. This column lists information pertinent to the maintenance function being performed as indicated in the MAC.

Table 1. Maintenance Allocation Chart for Space Heater, Convective.

(1) GROUP NUMBER	(2) COMPONENT/ ASSEMBLY	(3) MAINTENANCE FUNCTION	(4) MAINTENANCE LEVEL					(5) TOOLS AND EQUIPMENT REFERENCE CODE	(6) REMARKS CODE
			FIELD		SUSTAINMENT				
			UNIT		DIRECT SUPPORT	GENERAL SUPPORT	DEPOT		
			C	O	F	H	D		
00	Convective Space Heater								
01	In-Tent Controller Assembly	Inspect Test Replace	0.1 0.1 0.1	0.1 0.2 0.1			1 1		
0101	In-Tent Controller	Inspect Test Replace	0.1 0.1 0.1	0.1 0.2 0.1			1 1		
0102	In-Tent Controller Cable	Inspect Test Replace	0.1 0.1 0.1	0.1 0.2 0.1			1		
02	Battery Pack Assy	Inspect Test Service Replace	0.1 0.1 0.1 0.2	0.1 0.1 0.5 0.2			1 3 1	A,B	
03	External Fuel System	Inspect Service Replace	0.3 0.3 1.0	0.3 0.2 1.0			1	C	
0301	Fuel Supply Quick Disconnect	Inspect Replace	0.1 0.1	0.1 0.2			1		
0302	Fuel Solenoid Valve and Sediment Strainer Assembly	Inspect Service Replace	0.1 0.1 0.5	0.1 0.2 0.5				A,C	
0303	Fuel Hose	Inspect Replace	0.1 0.1	0.1 0.3			1		
04	Electronic Control System	Inspect Repair Replace	0.4 0.4 0.8	0.2 0.2 0.8			1		
0401	Heater Control Assembly	Inspect Replace	0.1 0.1	0.2			1		
0402	Wire Harness	Inspect Repair Replace	0.1 0.1 0.8	0.2 0.2 0.8			1		
0403	Power Control Board	Inspect Replace	0.1 0.1	0.3			1		
0404	Ignition Pack Assembly	Inspect Replace	0.1 0.1	0.3			1		
05	Dust Cover Assembly	Inspect Replace	0.1 0.1	0.1 0.2			1		

Table 1. Maintenance Allocation Chart for Space Heater, Convective – Continued

(1) GROUP NUMBER	(2) COMPONENT/ ASSEMBLY	(3) MAINTENANCE FUNCTION	(4) MAINTENANCE LEVEL					(5) TOOLS AND EQUIPMENT REFERENCE CODE	(6) REMARKS CODE
			FIELD		SUSTAINMENT				
			UNIT		DIRECT SUPPORT	GENERAL SUPPORT	DEPOT		
			C	O	F	H	D		
06	Combustion Blower Assembly	Inspect Replace	0.2	0.5				1	
0601	Combustion Air Blower Assembly	Inspect Replace	0.1	0.3				1	
0602	Combustion Air Blower Duct Assembly	Inspect Replace	0.1	0.1 0.2				1	
07	Combustion Air Inlet Assembly	Inspect Replace	0.1	0.3				1	
08	Upper Housing Assembly	Inspect Service Replace	0.1	0.1 0.1					
09	Exhaust Grommet	Inspect Replace	0.1	0.2					
10	Duct Adapters	Inspect Replace	0.1	0.1					
11	Heated Air Blower Assembly	Inspect Test Replace	0.1	0.1 0.2 0.3				1 1	
12	Internal Fuel System	Inspect Service Replace	0.2	0.5 0.7				1	
1201	Fuel Pump Assembly	Inspect Test Replace	0.1	0.2 0.5				1 1	
1202	Internal Fuel Lines	Inspect Replace	0.1	0.2				1	
1203	Float Assembly	Inspect Replace	0.1	0.5				1	
13	Burner Assembly and Related Components	Remove Inspect Service Replace	0.1	0.3 0.2 0.5 0.7				1 1 1	A
1301	Burner Assembly	Remove Inspect Service Replace	0.1	0.3 0.2 0.5 0.7				1 1	
1302	Flame Sensor	Replace	0.2					2	A
1303	Glow Plug	Replace	0.2					2	A

Table 1. Maintenance Allocation Chart for Space Heater, Convective.

(1) GROUP NUMBER	(2) COMPONENT/ ASSEMBLY	(3) MAINTENANCE FUNCTION	(4) MAINTENANCE LEVEL					(5) TOOLS AND EQUIPMENT REFERENCE CODE	(6) REMARKS CODE
			FIELD		SUSTAINMENT				
			UNIT		DIRECT SUPPORT	GENERAL SUPPORT	DEPOT		
			C	O	F	H	D		
14	Thermoelectric Generator (TEG)	Inspect Test Replace	0.1	0.2 0.2 0.5				1 1	D
15	Heat Exchanger	Remove Service Inspect Replace		0.5 0.2 0.5 0.7				1 1 1 1	D
16	Lower Housing Assembly	Inspect Service	0.1	0.1					
17	Air Return and Supply Ducts With Debris Grill	Inspect Repair	0.1	0.1					
18	Spares, Tools, and Accessories	Inspect	0.1						E

Table 2. Tools and Test Equipment for Space Heater, Convective.

(1) TOOL OR TEST EQUIPMENT REF CODE	(2) MAINTENANCE LEVEL	(3) NOMENCLATURE	(4) NATIONAL STOCK NUMBER	(5) TOOL NUMBER
1	O	Tool Kit, General Mechanics.	5180-00-699-5273	SC 5180-90-CL05
2	C,O	Wrench, 9/16 in and 12 mm (included with on-board spares and tool at inlet end of heater).		
3	C,O	Battery Charging Adapter (included with heater and stowed in accessory bag).		

Table 3. Remarks for Space Heater, Convective.

REMARKS CODE	REMARKS
A	Spare items and wrench are stored behind the duct adapter at the breathable air inlet end of the heater.
B	Two spare 20 amp fuses are mounted behind compartment cover.
C	A gasket and screen are supplied with rest of on-board spares and tools.
D	Visual inspection.
E	Replace any spares that have been used.

UNIT MAINTENANCE
SPACE HEATER, CONVECTIVE
(NSN 4520-01-431-8927)

REPAIR PARTS AND SPECIAL TOOLS LIST

INTRODUCTION

SCOPE

This RPSTL lists and authorizes spares and repair parts; special tools; special test, measurement, and diagnostic equipment (TMDE); and other special support equipment required for performance of operator, unit, and direct support maintenance of the Space Heater, Convective (SHC). It authorizes the requisitioning, issue, and disposition of spares, repair parts, and special tools as indicated by the source, maintenance, and recoverability (SMR) codes.

GENERAL

In addition to the Introduction work package, this RPSTL is divided into the following work packages.

1. Repair Parts List Work Packages. Work packages containing lists of spares and repair parts authorized by this RPSTL for use in the performance of maintenance. These work packages also include parts which must be removed for replacement of the authorized parts. Parts lists are composed of functional groups in ascending alphanumeric sequence, with the parts in each group listed in ascending figure and item number sequence. Sending units, brackets, filters, and bolts are listed with the component they mount on. Bulk materials are listed by item name in FIG. BULK at the end of the work packages. Repair parts kits are listed separately in their own functional group and work package. Repair parts for reparable special tools are also listed in a separate work package. Items listed are shown on the associated illustrations.
2. Special Tools List Work Packages. Work packages containing lists of special tools, special TMDE, and special support equipment authorized by this RPSTL (as indicated by Basis of Issue (BOI) information in the DESCRIPTION AND USABLE ON CODE (UOC) column). Tools that are components of common tool sets and/or Class VII are not listed.
3. Cross-Reference Indexes Work Packages. There are 2 cross-reference indexes work packages in this RPSTL: the National Stock Number (NSN) Index work package, and the Part Number (P/N) Index work package. The National Stock Number Index work package refers you to the figure and item number. The Part Number Index work package refers you to the figure and item number.

EXPLANATION OF COLUMNS IN THE REPAIR PARTS LIST AND SPECIAL TOOLS LIST WORK PACKAGES

ITEM NO. (Column (1)). Indicates the number used to identify items called out in the illustration.

SMR CODE (Column (2)). The SMR code containing supply/requisitioning information, maintenance level authorization criteria, and disposition instruction, shown in the following breakout:

<u>Source Code</u>	<u>Maintenance Code</u>	<u>XX</u>	<u>Recoverability Code</u>
<p><u>XX</u> 1st two positions: How to get an item.</p>	<p>3rd position: Who can install, re-place, or use the item.</p>	<p><u>XX</u> 4th position: Who can do complete re-pair* on the item.</p>	<p><u>X</u> 5th position: Who determines disposition action on unserviceable items.</p>

*Complete Repair: Maintenance capacity, capability, and authority to perform all corrective maintenance tasks of the "Repair" function in a use/user environment in order to restore serviceability to a failed item.

Source Code. The source code tells you how you get an item needed for maintenance, repair, or overhaul of an end item/equipment. Explanations of source codes follow:

<u>Source Code</u>	<u>Application/Explanation</u>
<p>PA PB PC PD FE PF PG</p>	<p>Stock items; use the applicable NSN to requisition/request items with these source codes. They are authorized to the level indicated by the code entered in the 3rd position of the SMR code.</p>
	<p>NOTE</p>
	<p>Items coded PC are subject to deterioration.</p>
<p>KD KF KB</p>	<p>Items with these codes are not to be requested/requisitioned individually. They are part of a kit which is authorized to the maintenance level indicated in the 3rd position of the SMR code. The complete kit must be requisitioned and applied.</p>
<p>MO-Made at unit/ AVUM level MF-Made at DS/ AVIM level MH-Made at GS level ML-Made at SRA</p>	<p>Items with these codes are not to be requisitioned/requested individually. They must be made from bulk material which is identified by the P/N in the DESCRIPTION AND USABLE ON CODE (UOC) column and listed in the bulk material group work</p>

MD-Made at depot	package of the RPSTL. If the item is authorized to you by the 3rd position code of the SMR code, but the source code indicates it is made at higher level, order the item from the higher level of maintenance.
AO-Assembled by unit/AVUM level AF-Assembled by DS/AVIM level AH-Assembled by GS level AL-Assembled by SRA AD-Assembled by depot	Items with these codes are not to be requested/requisitioned individually. The parts that make up the assembled item must be requisitioned or fabricated and assembled at the level of maintenance indicated by the source code. If the 3rd position of the SMR code authorizes you to replace the item, but the source code indicates the item is assembled at a higher level, order the item from the higher level of maintenance.
XA	Do not requisition an "XA" coded item. Order the next higher assembly. (Refer to NOTE below.)
XE	If an item is not available from salvage, order it using the CAGEC and P/N.
XC	Installation drawings, diagrams, instruction sheets, field service drawings; identified by manufacturer's P/N.
XD	Item is not stocked. Order an XD-coded item through normal supply channels using the CAGEC and P/N given, if no NSN is available.

NOTE

Cannibalization or controlled exchange, when authorized, may be used as a source of supply for items with the above source codes except for those items source coded "XA" or those aircraft support items restricted by requirements of AR 750-1.

Maintenance Code. Maintenance codes tell you the level(s) of maintenance authorized to use and repair support items. The maintenance codes are entered in the third and fourth positions of the SMR code as follows:

Third Position. The maintenance code entered in the third position tells you the lowest maintenance level authorized to remove, replace, and use an item. The maintenance code entered in the third position will indicate authorization to the following levels of maintenance:

Maintenance

<u>Code</u>	<u>Application/Explanation</u>
C —	Crew or operator maintenance done within unit/AVUM maintenance.
O —	Unit level/AVUM maintenance can remove, replace, and use the item.
F —	Direct support/AVIM maintenance can remove, replace, and use the item.
H —	General support maintenance can remove, replace, and use the item.
L —	Specialized repair activity can remove, replace, and use the item.
D —	Depot can remove, replace, and use the item.

Fourth Position. The maintenance code entered in the fourth position tells you whether or not the item is to be repaired and identifies the lowest maintenance level with the capability to do complete repair (perform all authorized repair functions).

NOTE

Some limited repair may be done on the item at a lower level of maintenance, if authorized by the Maintenance Allocation Chart (MAC) and SMR codes.

Maintenance

<u>Code</u>	<u>Application/Explanation</u>
O —	Unit/AVUM is the lowest level that can do complete repair of the item.
F —	Direct support/AVIM is the lowest level that can do complete repair of the item. H — General support is the lowest level that can do complete repair of the item.
L —	Specialized repair activity, Direct Support (DS) is the lowest level that can do complete repair of the item.
D —	Depot is the lowest level that can do complete repair of the item. Z — Nonreparable. No repair is authorized.
B —	No repair is authorized. No parts or special tools are authorized for maintenance of "B" coded item. However, the item may be reconditioned by adjusting, lubricating, etc., at the user level.

Recoverability Code. Recoverability codes are assigned to items to indicate the disposition action on unserviceable items. The recoverability code is shown in the fifth position of the SMR code as follows:

Recoverability

<u>Code</u>	<u>Application/Explanation</u>
Z —	Nonreparable item. When unserviceable, condemn and dispose of the item at the level of maintenance shown in the third position of the SMR code.
O —	Reparable item. When uneconomically repairable, condemn and dispose of the item at the unit level.
F —	Reparable item. When uneconomically repairable, condemn and dispose of the item at the direct support level.
H —	Reparable item. When uneconomically repairable, condemn and dispose of the item at the general support level.

- D — Repairable item. When beyond lower level repair capability, return to depot. Condemnation and disposal of item are not authorized below depot level.
- L — Repairable item. Condemnation and disposal not authorized below Specialized Repair Activity (SRA).
- A — Item requires special handling or condemnation procedures because of specific reasons (such as precious metal content, high dollar value, critical material, or hazardous material). Refer to appropriate manuals/directives for specific instructions.

NSN (Column (3)). The NSN for the item is listed in this column.

CAGEC (Column (4)). The Commercial and Government Entity Code (CAGEC) is a five-digit code which is used to identify the manufacturer, distributor, or Government agency/activity that supplies the item.

PART NUMBER (Column (5)). Indicates the primary number used by the manufacturer (individual, company, firm, corporation, or Government activity), which controls the design and characteristics of the item by means of its engineering drawings, specifications, standards, and inspection requirements to identify an item or range of items.

NOTE

When you use an NSN to requisition an item, the item you receive may have a different P/N from the number listed.

DESCRIPTION AND USABLE ON CODE (UOC) (Column (6)). This column includes the following information:

1. The federal item name, and when required, a minimum description to identify the item.
2. P/Ns of bulk materials are referenced in this column in the line entry to be manufactured or fabricated.
3. Hardness Critical Item (HCI). A support item that provides the equipment with special protection from electromagnetic pulse (EMP) damage during a nuclear attack.
4. The statement END OF FIGURE appears just below the last item description in column (6) for a given figure in both the repair parts list and special tools list work packages.

QTY (Column (7)). The QTY (quantity per figure) column indicates the quantity of the item used in the breakout shown on the illustration/figure, which is prepared for a functional group, subfunctional group, or an assembly. A "V" appearing in this column instead of a quantity indicates that the quantity is variable and quantity may change from application to application.

EXPLANATION OF CROSS-REFERENCE INDEXES WORK PACKAGES FORMAT AND COLUMNS

1. National Stock Number (NSN) Index Work Package.

STOCK NUMBER Column. This column lists the NSN in National item identification number (NIIN) sequence. The NIIN consists of the last nine digits of the NSN.

NSN
 (e.g., 5385-01-574-1476)
 NIIN

When using this column to locate an item, ignore the first four digits of the NSN. However, the complete NSN should be used when ordering items by stock number.

FIG. Column. This column lists the number of the figure where the item is identified/located. The figures are in numerical order in the repair parts list and special tools list work packages.

ITEM Column. The item number identifies the item associated with the figure listed in the adjacent FIG. column. This item is also identified by the NSN listed on the same line.

2. Part Number (P/N) Index Work Package. P/Ns in this index are listed in ascending alphanumeric sequence (vertical arrangement of letter and number combinations which places the first letter or digit of each group in order A through Z, followed by the numbers 0 through 9 and each following letter or digit in like order).

PART NUMBER Column. Indicates the P/N assigned to the item.

FIG. Column. This column lists the number of the figure where the item is identified/located in the repair parts list and special tools list work packages.

ITEM Column. The item number is the number assigned to the item as it appears in the figure referenced in the adjacent figure number column."

REFERENCE DESIGNATOR Column. Indicates the reference designator assigned to the item.

FIG. Column. This column lists the number of the figure where the item is identified/located in the repair parts list or special tools list work package.

ITEM Column. The item number is the number assigned to the item as it appears in the figure referenced in the adjacent figure number column.

SPECIAL INFORMATION

UOC. The UOC appears in the lower left corner of the Description Column heading. Usable on codes are shown as "UOC: .." in the Description Column (justified left) on the first line under the applicable item/nomenclature. Uncoded items are applicable to all models. Identification of the UOCs used in the RPSTL are:

<u>Code</u>	<u>Used On</u>
FSB	Space Heater, Convective

Associated Publications. The publications listed below pertain to the Kitchen, Field, Trailer Mounted and its components:

<u>Publication</u>	<u>Short Title</u>
TM 10-4520-262-13&P	Operator's, Unit, and Direct Support Maintenance Manual Space Heater, Convective

Fabrication Instructions. Bulk materials required to manufacture items are listed in the bulk material functional group of this RPSTL. Part numbers for bulk material are also referenced in the Description Column of the line item entry for the item to be manufactured/fabricated. Detailed fabrication instructions for items source coded to be manufactured or fabricated are found in this TM.

Index Numbers. Items which have the word BULK in the figure column will have an index number shown in the item number column. This index number is a cross-reference between the NSN / P/N index work packages and the bulk material list in the repair parts list work package.

HOW TO LOCATE REPAIR PARTS

1. When NSNs or P/Ns Are Not Known.

First. Using the table of contents, determine the assembly group to which the item belongs. This is necessary since figures are prepared for assembly groups and subassembly groups, and lists are divided into the same groups.

Second. Find the figure covering the functional group or the subfunctional group to which the item belongs.

Third. Identify the item on the figure and note the number(s).

Fourth. Look in the repair parts list work packages for the figure and item numbers. The NSNs and part numbers are on the same line as the associated item numbers.

2. When NSN Is Known.

First. If you have the NSN, look in the STOCK NUMBER column of the NSN index work package. The NSN is arranged in NIIN sequence. Note the figure and item number next to the NSN.

Second. Turn to the figure and locate the item number. Verify that the item is the one you are looking for.

3. When P/N Is Known.

First. If you have the PIN and not the NSN, look in the PART NUMBER column of the PIN index work package. Identify the figure and item number.

Second. Look up the item on the figure in the applicable repair parts list work package.

UNIT MAINTENANCE
SPACE HEATER, CONVECTIVE
(NSN 4520-01-431-8927)
IN-TENT CONTROLLER ASSEMBLY
REPAIR PARTS LIST

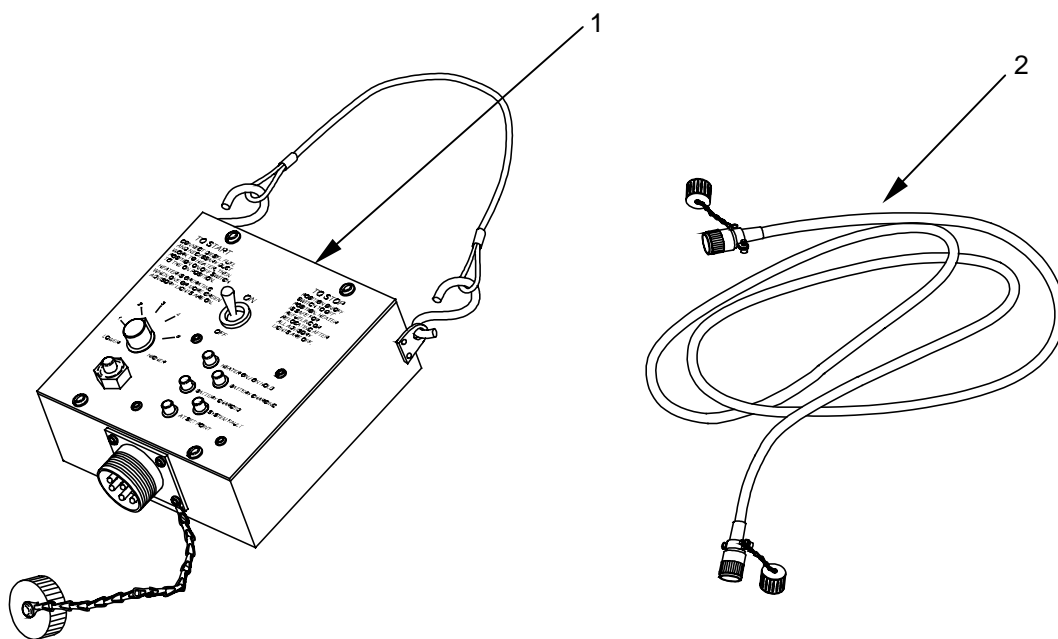

Figure 1. In-tent Controller Assembly

(1)	(2)	(3)	(4)	(5)	(6)	(7)
ITEM NO	SMR CODE	NATIONAL STOCK NUMBER	CAGEC	PART NUMBER	DESCRIPTION AND USABLE ON CODE (UOC)	QTY
					GROUP 1 FIG. 1 IN-TENT CONTROLLER ASSY	
1	PAOZZ	4520-01-493-2800	92878	5-13-5506	. IN-TENT CONTROLLER ASSY	1
2	PAOZZ	4520-01-493-2807	92878	5-13-5577	. REMOTE IN-TENT CONTROLLER ASSY CABLE	1
					END OF FIGURE	

UNIT MAINTENANCE
SPACE HEATER, CONVECTIVE
(NSN 4520-01-431-8927)
BATTERY PACK ASSEMBLY
REPAIR PARTS LIST

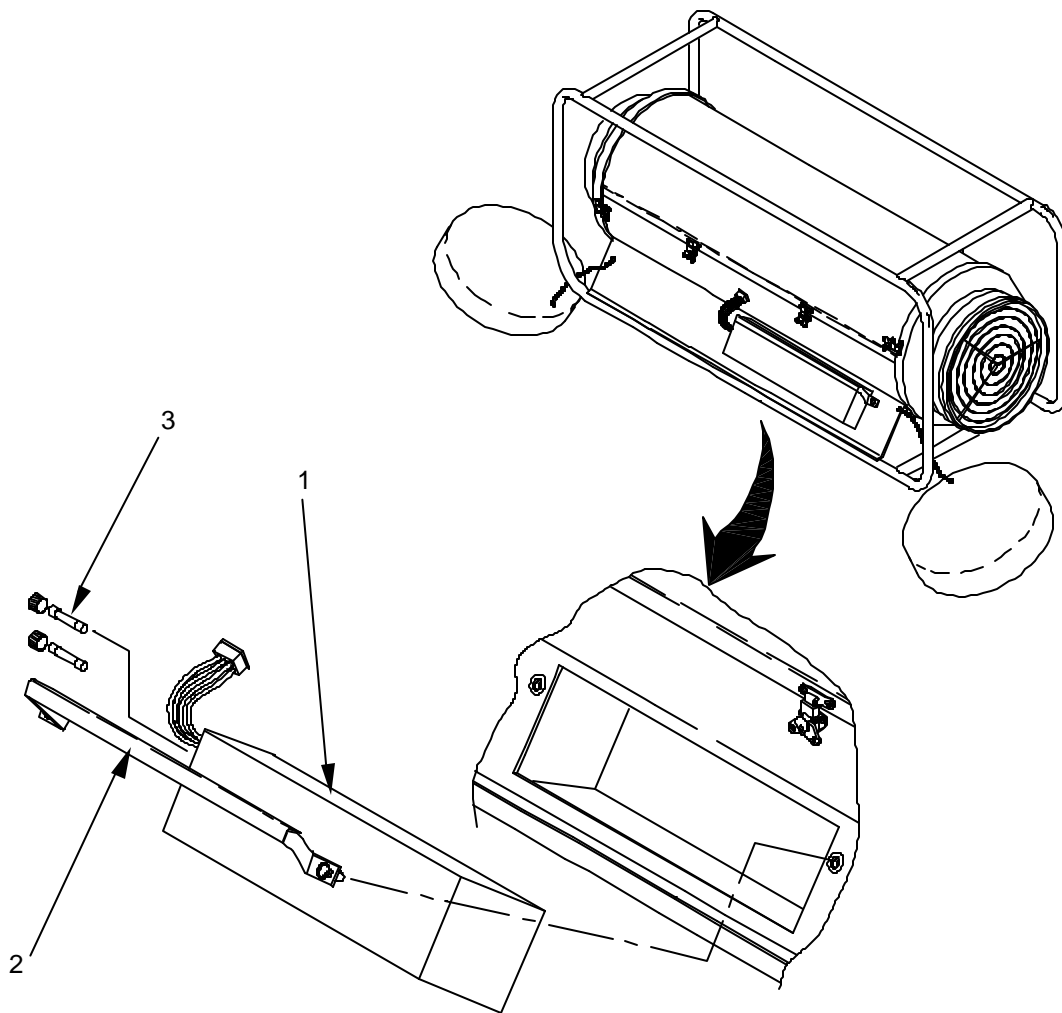

Figure 2. Battery Assembly

(1)	(2)	(3)	(4)	(5)	(6)	(7)
ITEM NO	SMR CODE	NATIONAL STOCK NUMBER	CAGEC	PART NUMBER	DESCRIPTION AND USABLE ON CODE (UOC)	QTY
					GROUP 2 FIG. 2 BATTERY ASSY	
1	PAOZZ	4520-01-493-2796	92878	5-13-5469	. BATTERY PACK MODIFIED	1
2	PAOZZ	4520-01-493-2794	92878	5-13-5468	. . RETAINER, BATTERY.....	1
3	PAOZZ	4520-01-493-2777	92878	46273	. . FUSE, 20 AMP	2
					END OF FIGURE	

UNIT MAINTENANCE
SPACE HEATER, CONVECTIVE
(NSN 4520-01-431-8927)
EXTERNAL FUEL SYSTEM
REPAIR PARTS LIST

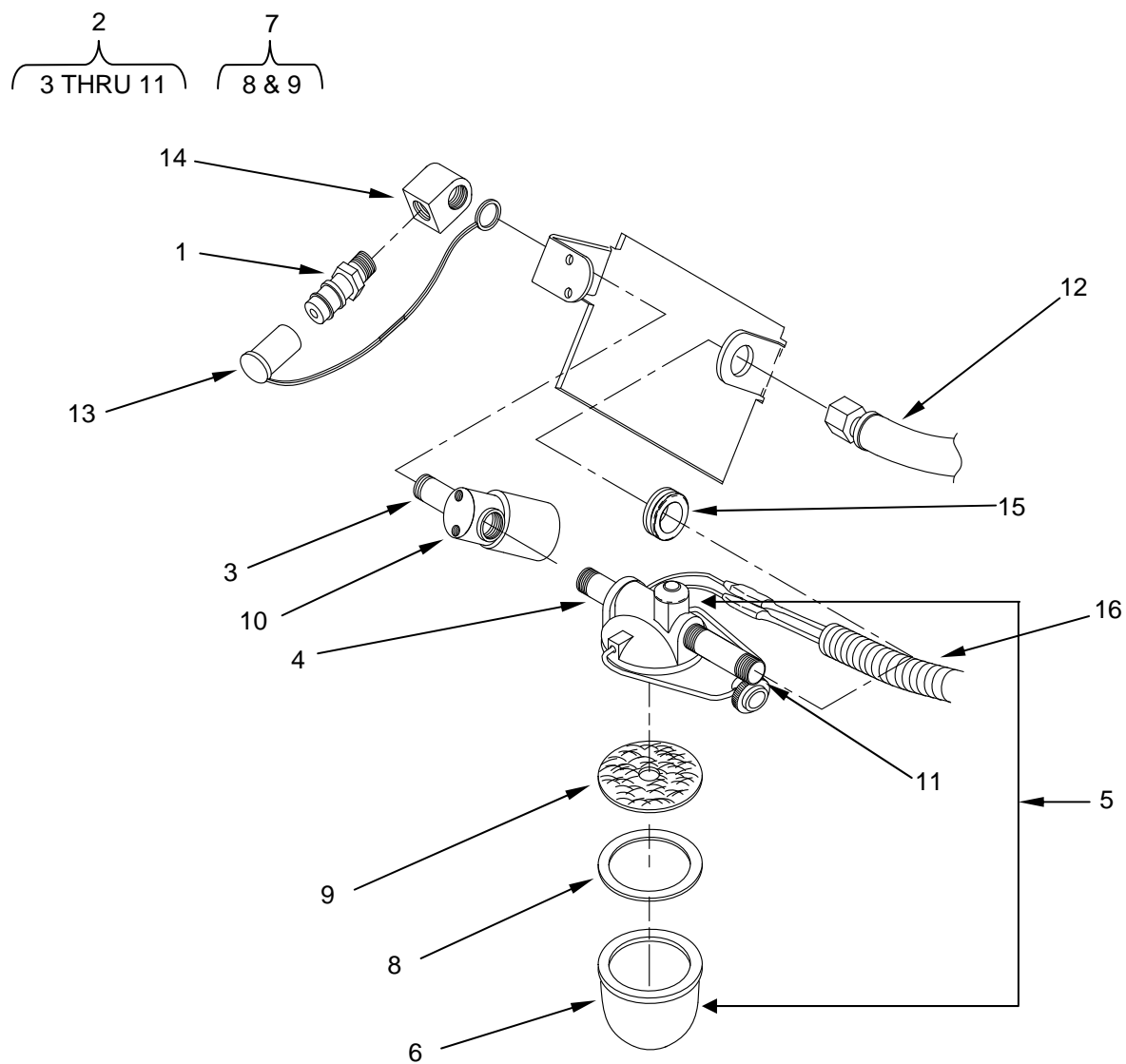

Figure 3. External Fuel System Components.

(1)	(2)	(3)	(4)	(5)	(6)	(7)
ITEM NO	SMR CODE	NATIONAL STOCK NUMBER	CAGEC	PART NUMBER	DESCRIPTION AND USABLE ON CODE (UOC)	QTY
					GROUP 03 FIG. 3 EXTERNAL FUEL SYSTEM	
1	PAOZZ	4730-01-206-8726	73992	HP2-4374	. FUEL QUICK DISCONNECT	1
2	PAOZZ	4520-01-493-2814	92878	5-13-5637	. SEDIMENT STRAINER ASSY	1
3	PAOZZ	4730-00-193-2707	96906	MS51846-6	. . NIPPLE 1/8 NPT X 1 1/2	1
4	XDOZZ		92878	3789	. . NIPPLE CLOSE 1/8 PIPE.....	1
5	PAOZZ	2910-00-905-9792	96906	MS51086-2	. . STRAINER, SEDIMENT	1
6	XAOZZ		92878	4782401	. . . SEDIMENT BOWL.....	1
7	PAOZZ	4520-01-493-2816	92878	5-13-5638	. . . KIT, FUEL STRAINER.....	1
8	KFOZZ		92878	5-13-5530 GASKET, FUEL STRAINER.....	1
9	KFOZZ		92878	5-13-5531 SCREEN, FUEL STRAINER	1
10	PAOZZ	4520-01-493-2790	92878	5-13-5439	. . FUEL SOLENOID VALVE	1
11	PAOZZ	4730-01-544-7472	92878	1321	. . NIPPLE BRASS 1/8 X 2	1
12	PAOZZ	4520-01-493-2782	92878	60478-15	. FUEL HOSE ASSY.....	1
13	PAOZZ	4520-01-493-2785	92878	5-13-5616	. FUEL CAP ASSEMBLY	1
14	XDOZZ		92878	1366	. ELBOW FEMALE	1
15	XDOZZ	4520-01-492-9125	92878	5914	. GROMMET	1
16	PAOZZ	4520-01-493-2813	92878	52417-9	. WIRE LOOM.....	AR
					END OF FIGURE	

UNIT MAINTENANCE

SPACE HEATER, CONVECTIVE

(NSN 4520-01-431-8927)

ELECTRONIC CONTROL SYSTEM

REPAIR PARTS LIST

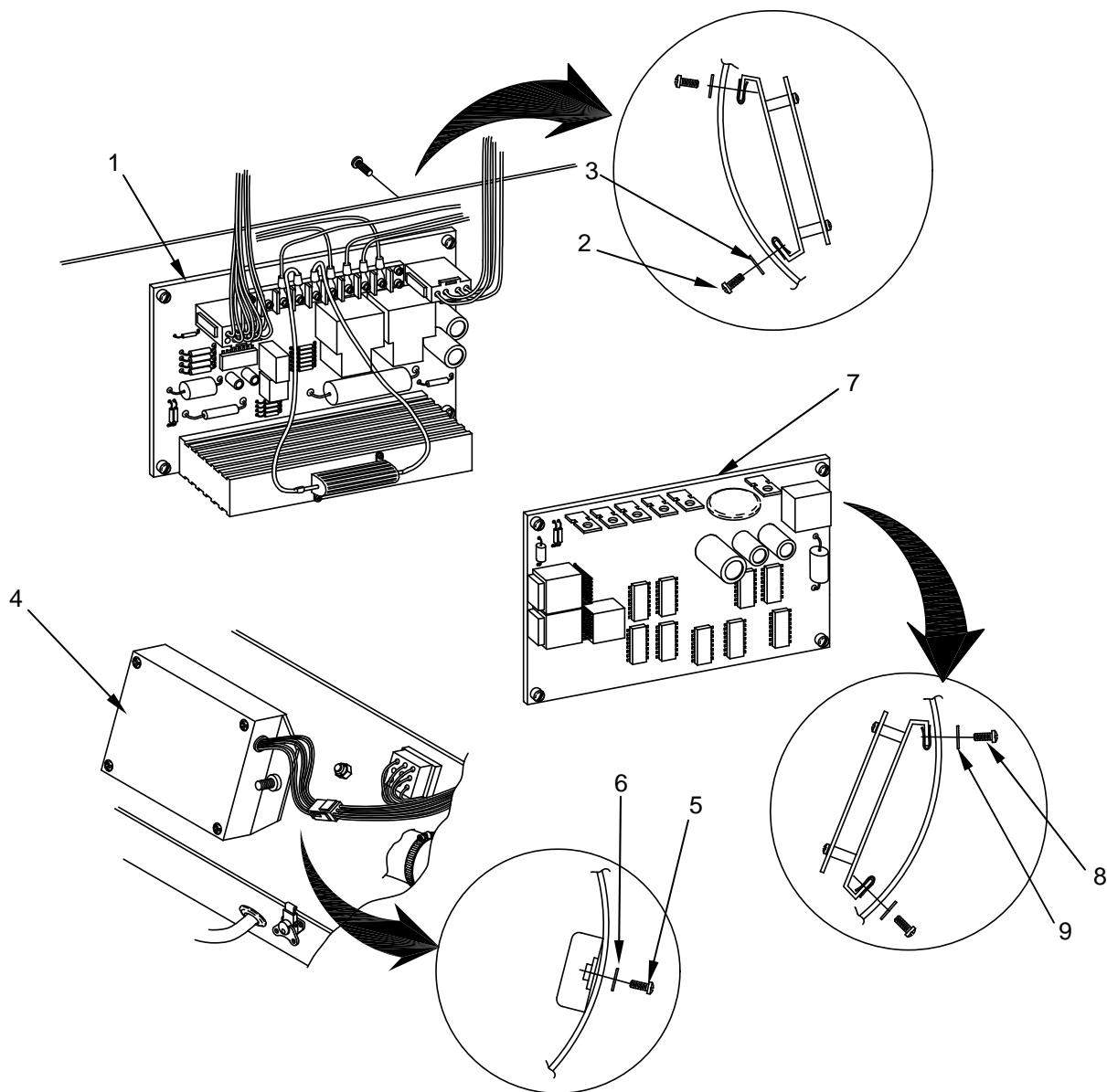

Figure 4. Electronic Control System (Sheet 1 of 2).

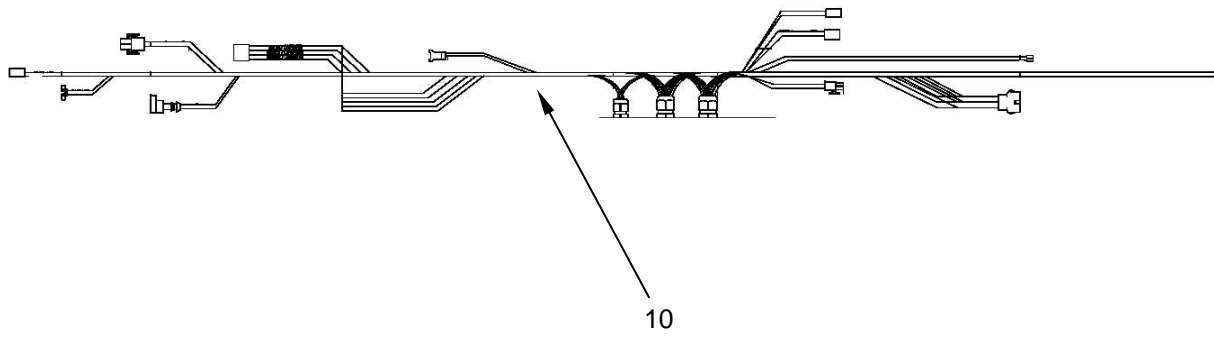

Figure 4. Electronic Control System (Sheet 2 of 2).

(1)	(2)	(3)	(4)	(5)	(6)	(7)
ITEM NO	SMR CODE	NATIONAL STOCK NUMBER	CAGEC	PART NUMBER	DESCRIPTION AND USABLE ON CODE (UOC)	QTY
					GROUP 04 FIG. 4 ELECTRONIC CONTROL SYSTEM	
1	PAOZZ	4520-01-493-2806	92878	5-13-5565	. POWER CONTROL ASSY	1
2	PAOZZ	5305-00-432-4171	96906	MS51861-36	SCREW, TAPPING #8.....	4
3	PAOZZ	5310-00-193-7577	96906	MS35333-36	. . WASHER, INT LOCK	4
4	PAOZZ	4520-01-493-2779	92878	60468	. IGNITION PACK.....	1
5	PAOZZ	5305-00-988-1728	96906	MS35206-287	SCREW, ¼" 20x2.00	2
6	PAOZZ	5310-00-209-0786	96906	MS35335-19	. WASHER, EXT LOCK ¼".....	4
7	PAOZZ	4520-01-493-2805	92878	5-13-5568	. HEATER CONTROL ASSY	1
8	PAOZZ	5305-00-432-4171	96906	MS51861-36	. SCREW, TAPPING #8	4
9	PAOZZ	5310-00-559-0070	96906	MS35333-38	. . WASHER, INT LOCK	4
10	PAOZZ	4520-01-493-2808	92878	5-13-5579	WIRE HARNESS	1
					END OF FIGURE	

UNIT MAINTENANCE
SPACE HEATER, CONVECTIVE
(NSN 4520-01-431-8927)
DUST COVER ASSEMBLY
REPAIR PARTS LIST

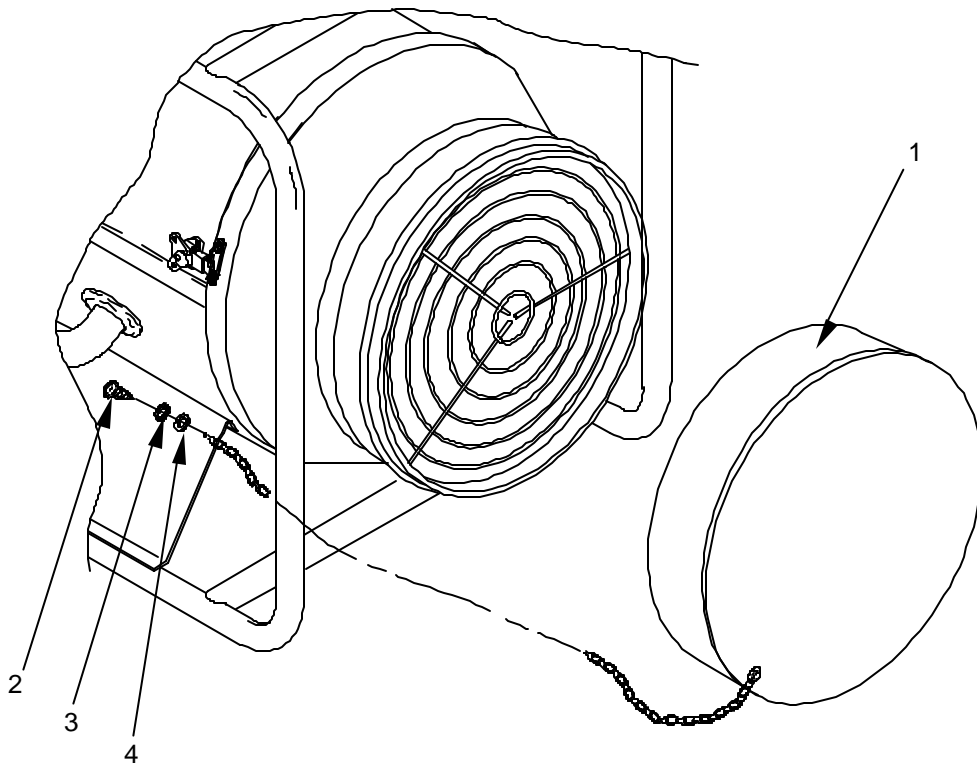

Figure 5. Chain and Dust Cover Assembly
0050 00-(1 Blank)/2

(1)	(2)	(3)	(4)	(5)	(6)	(7)
ITEM NO	SMR CODE	NATIONAL STOCK NUMBER	CAGEC	PART NUMBER	DESCRIPTION AND USABLE ON CODE (UOC)	QTY
					GROUP 5 FIG. 5 CHAIN AND DUST COVER ASSY	
1	PAOZZ	4520-01-493-2793	92878	5-13-5461	. DUST COVER ASSY.....	2
2	PAOZZ	5305-00-432-4171	96906	MS51861-36	.. SCREW	2
3	PAOZZ	5310-00-193-7577	96906	MS35333-36	.. WASHER, INT LOCK	2
4	PAOZZ	5310-00-014-5850	96906	MS27183-42	.. WASHER, FLAT 7/32 ID	2
					END OF FIGURE	

UNIT MAINTENANCE
SPACE HEATER, CONVECTIVE
(NSN 4520-01-431-8927)
COMBUSTION BLOWER ASSEMBLY
REPAIR PARTS LIST

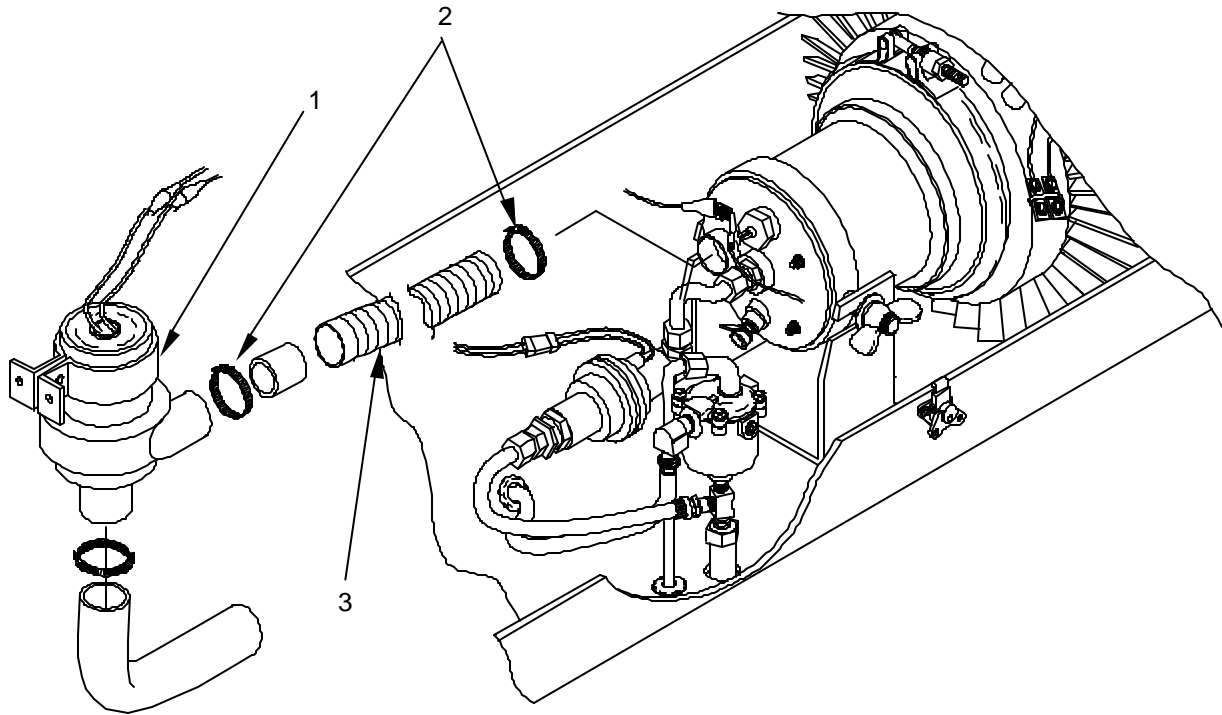

Figure 6. Internal Combustion Air System

(1)	(2)	(3)	(4)	(5)	(6)	(7)
ITEM NO	SMR CODE	NATIONAL STOCK NUMBER	CAGEC	PART NUMBER	DESCRIPTION AND USABLE ON CODE (UOC)	QTY
					GROUP 6 FIG. 6 INTERNAL COMBUSTION AIR SYSTEM	
1	PAOZZ	4520-01-493-2804	92878	5-13-5564	. COMBUSTION AIR BLOWER ASSY.....	1
2	PAOZZ		92878	49602	. CLAMP HOSE MICRO GEAR	2
3	PAOZZ		92878	5-13-5511	. DUCTING, 1" I.D.....	1
					END OF FIGURE	

UNIT MAINTENANCE
SPACE HEATER, CONVECTIVE
(NSN 4520-01-431-8927)
COMBUSTION AIR INLET ASSEMBLY
REPAIR PARTS LIST

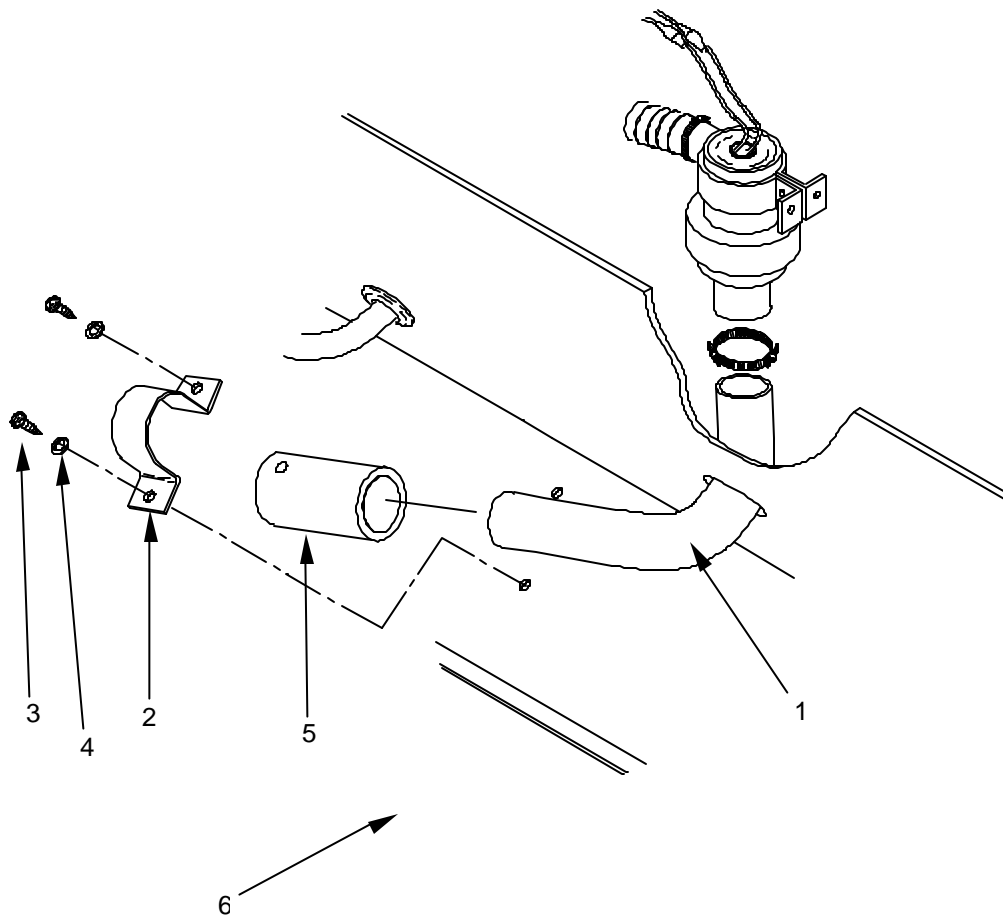

Figure 7. Combustion Air Inlet Assembly

(1)	(2)	(3)	(4)	(5)	(6)	(7)
ITEM NO	SMR CODE	NATIONAL STOCK NUMBER	CAGEC	PART NUMBER	DESCRIPTION AND USABLE ON CODE (UOC)	QTY
					GROUP 7 FIG. 7 EXTERNAL AIR COMBUSTION SYSTEM	
1	PAOZZ	4520-01-493-2795	92878	5-13-5490	. COMBUSTION AIR INLET ASSY.....	1
2	PAOZZ		92878	5-13-5162	. CLAMP COMBUSTION AIR TUBE.....	1
3	PAOZZ	5305-00-989-7434	96906	MS35207-263	. SCREW PHM 10-32 X 1/2	2
4	PAOZZ	5310-00-067-6357	96906	MS45904-69	. WASHER LK INT EXT 1/4	2
5	PAOZZ		92878	5-13-5489	. TUBE, ADAPTER	1
6	PAOZZ		92878	5-13-5422	. COVER COMBUSTION TUBE INTAKE ..	1
					END OF FIGURE	

UNIT MAINTENANCE
SPACE HEATER, CONVECTIVE
(NSN 4520-01-431-8927)
UPPER HOUSING ASSEMBLY
REPAIR PARTS LIST

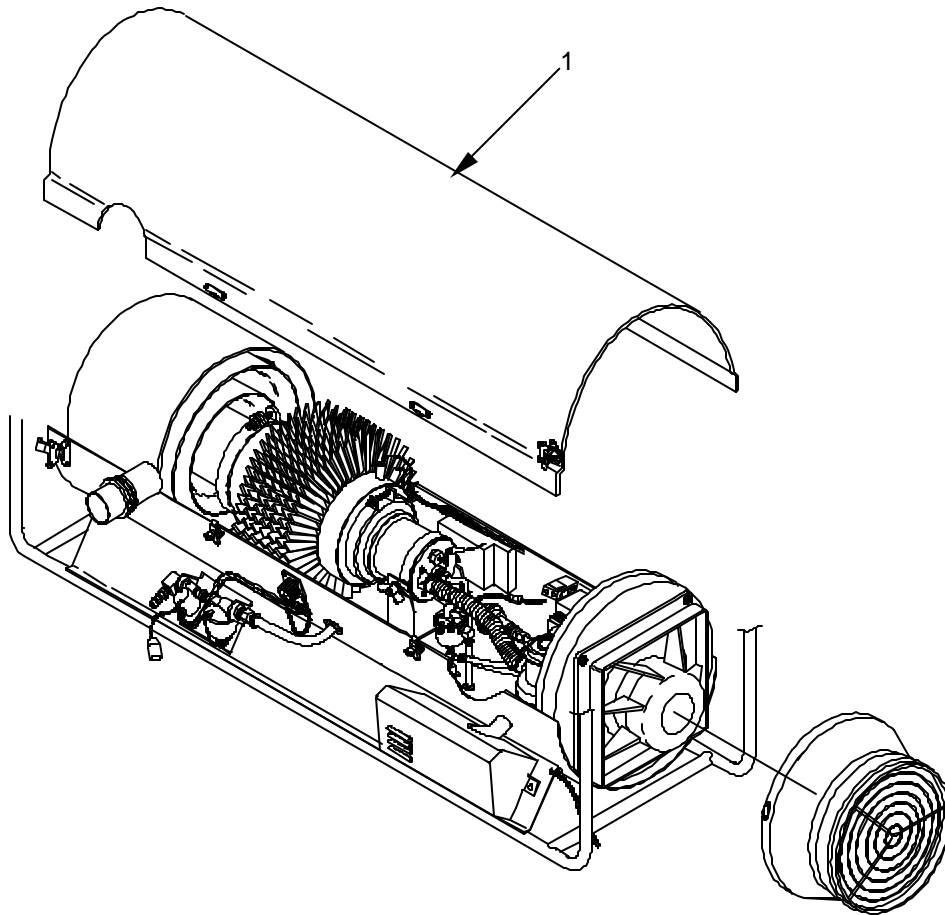

Figure 8. Upper Housing Assembly

(1)	(2)	(3)	(4)	(5)	(6)	(7)
ITEM NO	SMR CODE	NATIONAL STOCK NUMBER	CAGEC	PART NUMBER	DESCRIPTION AND USABLE ON CODE (UOC)	QTY
1	PAOZZ	4520-01-493-2788	92878	5-13-5634	GROUP 8 FIG. 8. UPPER HOUSING ASSY . UPPER HOUSING ASSY..... END OF FIGURE	1

UNIT MAINTENANCE
SPACE HEATER, CONVECTIVE
(NSN 4520-01-431-8927)
EXHAUST GROMMET
REPAIR PARTS LIST

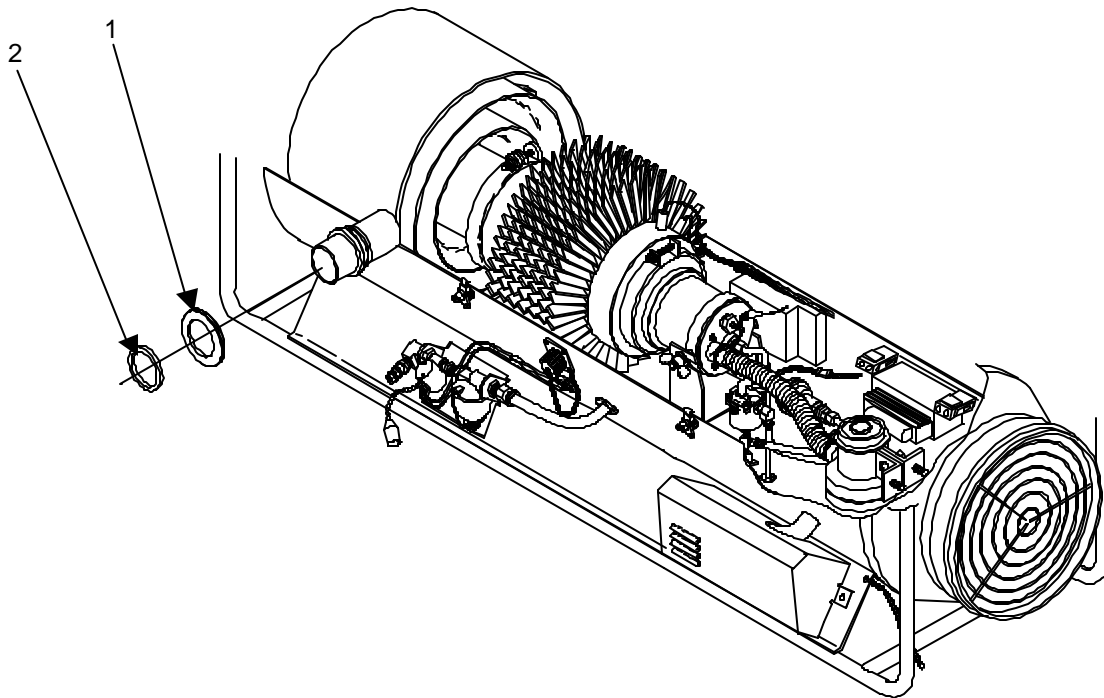

Figure 9. Exhaust Grommet

(1)	(2)	(3)	(4)	(5)	(6)	(7)
ITEM NO	SMR CODE	NATIONAL STOCK NUMBER	CAGEC	PART NUMBER	DESCRIPTION AND USABLE ON CODE (UOC)	QTY
					GROUP 9 FIG. 9 EXHAUST GROMMET	
1	PAOZZ	4520-01-493-2801	92878	5-13-5519	. EXHAUST GROMMET	1
2	PAOZZ	4520-01-493-2803	92878	5-13-5539	. SEAL, EXHAUST	1
					END OF FIGURE	

UNIT MAINTENANCE
SPACE HEATER, CONVECTIVE
(NSN 4520-01-431-8927)
DUCT ADAPTERS
REPAIR PARTS LIST

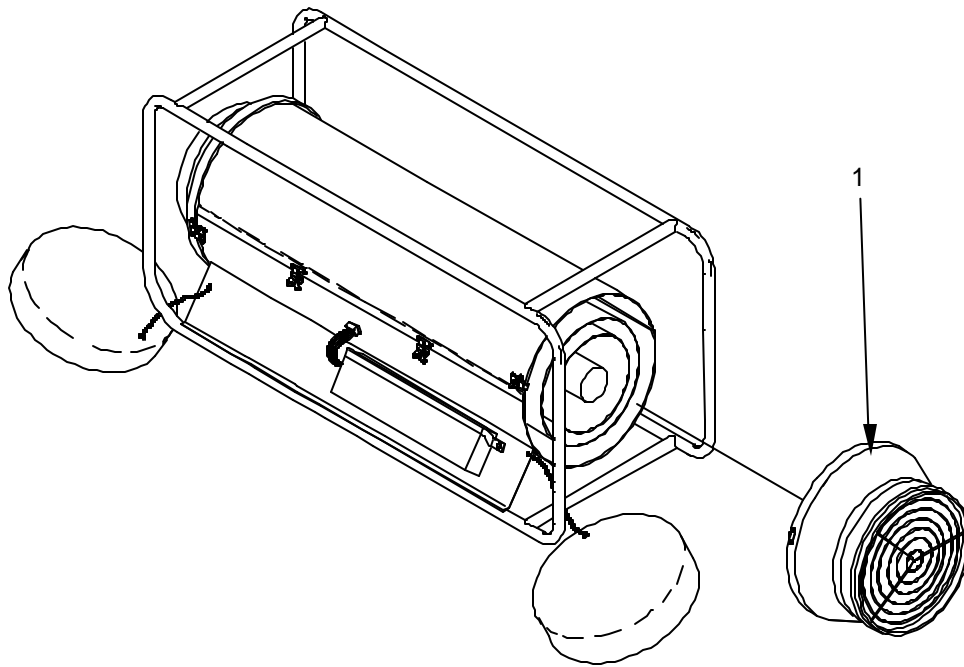

Figure 10. Duct Adapters

(1)	(2)	(3)	(4)	(5)	(6)	(7)
ITEM NO	SMR CODE	NATIONAL STOCK NUMBER	CAGEC	PART NUMBER	DESCRIPTION AND USABLE ON CODE (UOC)	QTY
1	PAOZZ	4520-01-493-2787	92878	5-13-5435	GROUP 10 FIG. 10 DUCT ADAPTERS . DUCT ADAPTER	2
END OF FIGURE						

UNIT MAINTENANCE
SPACE HEATER, CONVECTIVE
(NSN 4520-01-431-8927)
HEATED AIR BLOWER ASSEMBLY
REPAIR PARTS LIST

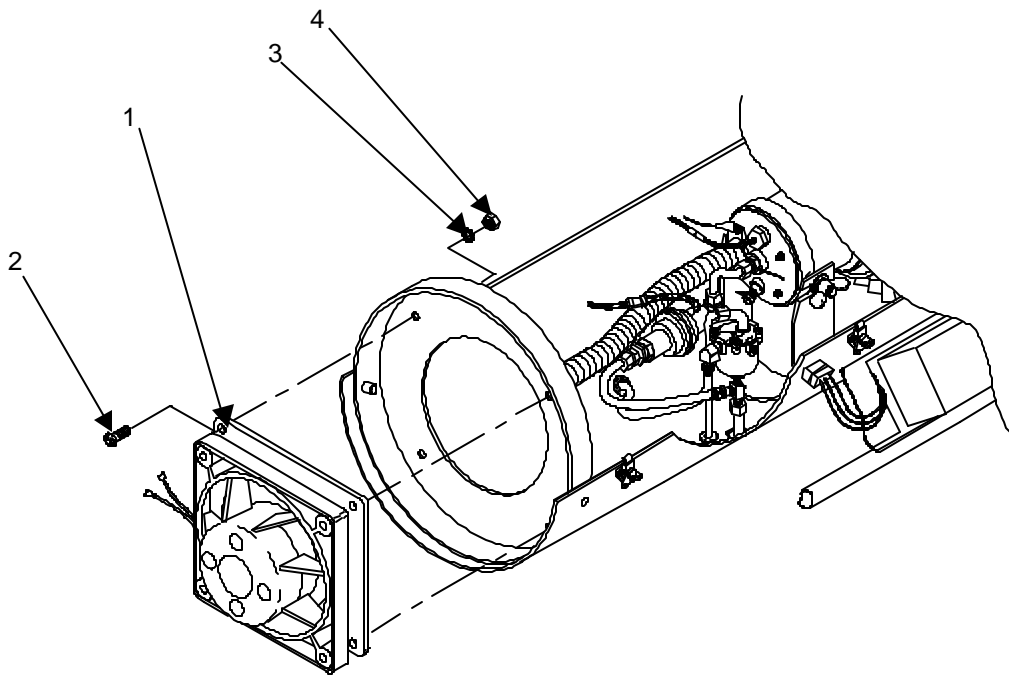

Figure 11. Heated Air Blower Assembly

(1)	(2)	(3)	(4)	(5)	(6)	(7)
ITEM NO	SMR CODE	NATIONAL STOCK NUMBER	CAGEC	PART NUMBER	DESCRIPTION AND USABLE ON CODE (UOC)	QTY
					GROUP 11 FIG. 11 HEATED AIR BLOWER ASSY	
1	PAOZZ	4520-01-493-2862	92878	5-13-5425	. HEATED AIR BLOWER ASSY.....	1
2	PAOZZ	5305-00-989-7435	96906	MS35207-264	. SCREW PHM 10/32 X 5/8	4
3	PAOZZ	5310-00-596-7691	96906	MS35335-32	. WASHER, LOCK, EXT #10.....	4
4	PAOZZ	5310-00-789-0398	19207	7951286	. NUT HEX KEP 10-32.....	4
					END OF FIGURE	

UNIT MAINTENANCE
SPACE HEATER, CONVECTIVE
(NSN 4520-01-431-8927)
INTERNAL FUEL SYSTEM
REPAIR PARTS LIST

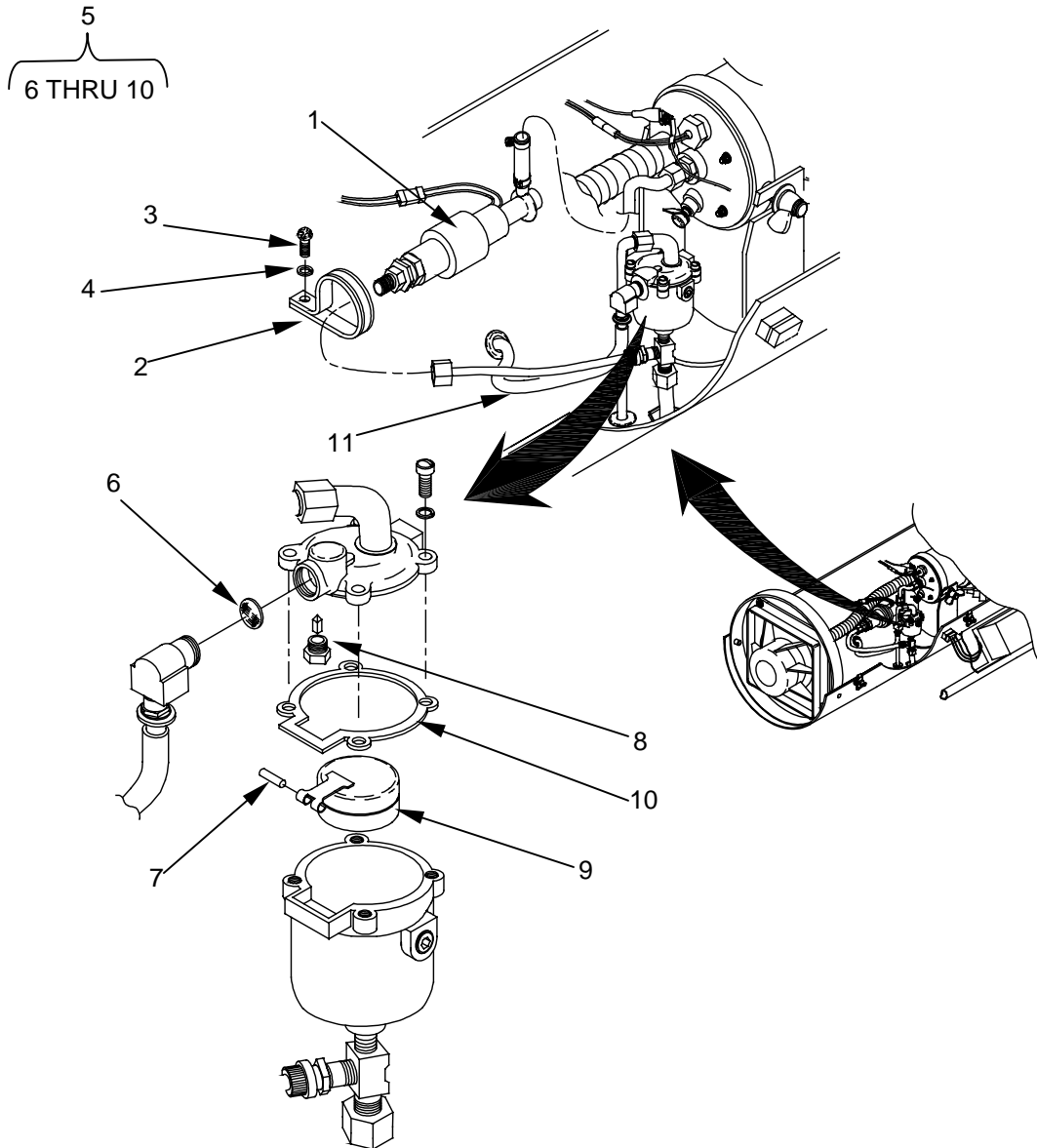

Figure 12. Internal Fuel System

(1)	(2)	(3)	(4)	(5)	(6)	(7)
ITEM NO	SMR CODE	NATIONAL STOCK NUMBER	CAGEC	PART NUMBER	DESCRIPTION AND USABLE ON CODE (UOC)	QTY
					GROUP 12 FIG. 12 INTERNAL FUEL SYSTEM	
1	PAOZZ	4520-01-493-2778	92878	60481	. FUEL PUMP	1
2	PAOZZ	5340-00-904-3705	96906	MS21333-82	. CLAMP, LOOP	1
3	PAOZZ	5305-00-989-7435	96906	MS35207-264	. SCREW PHM	1
4	PAOZZ	5310-00-596-7691	96906	MS35335-32	. WASHER LK EXT #10.....	1
5	PAOZZ	4520-01-493-2784	92878	60499	. FLOAT ASSY	1
6	XAOZZ		92878	26370	. . INLET SCREEN.....	1
7	XAOZZ		92878	1591	. . PIN.....	1
8	XAOZZ		92878	48389	. . NEEDLE AND SEAT	1
9	XAOZZ		92878	48390	. . FLOAT	1
10	XAOZZ		92878	1601	. . GASKET	1
11	PAOZZ	4520-01-493-2786	92878	60477	TUBING PARFLEX	AR
					END OF FIGURE	

UNIT MAINTENANCE
SPACE HEATER, CONVECTIVE
(NSN 4520-01-431-8927)
BURNER ASSEMBLY
REPAIR PARTS LISTS

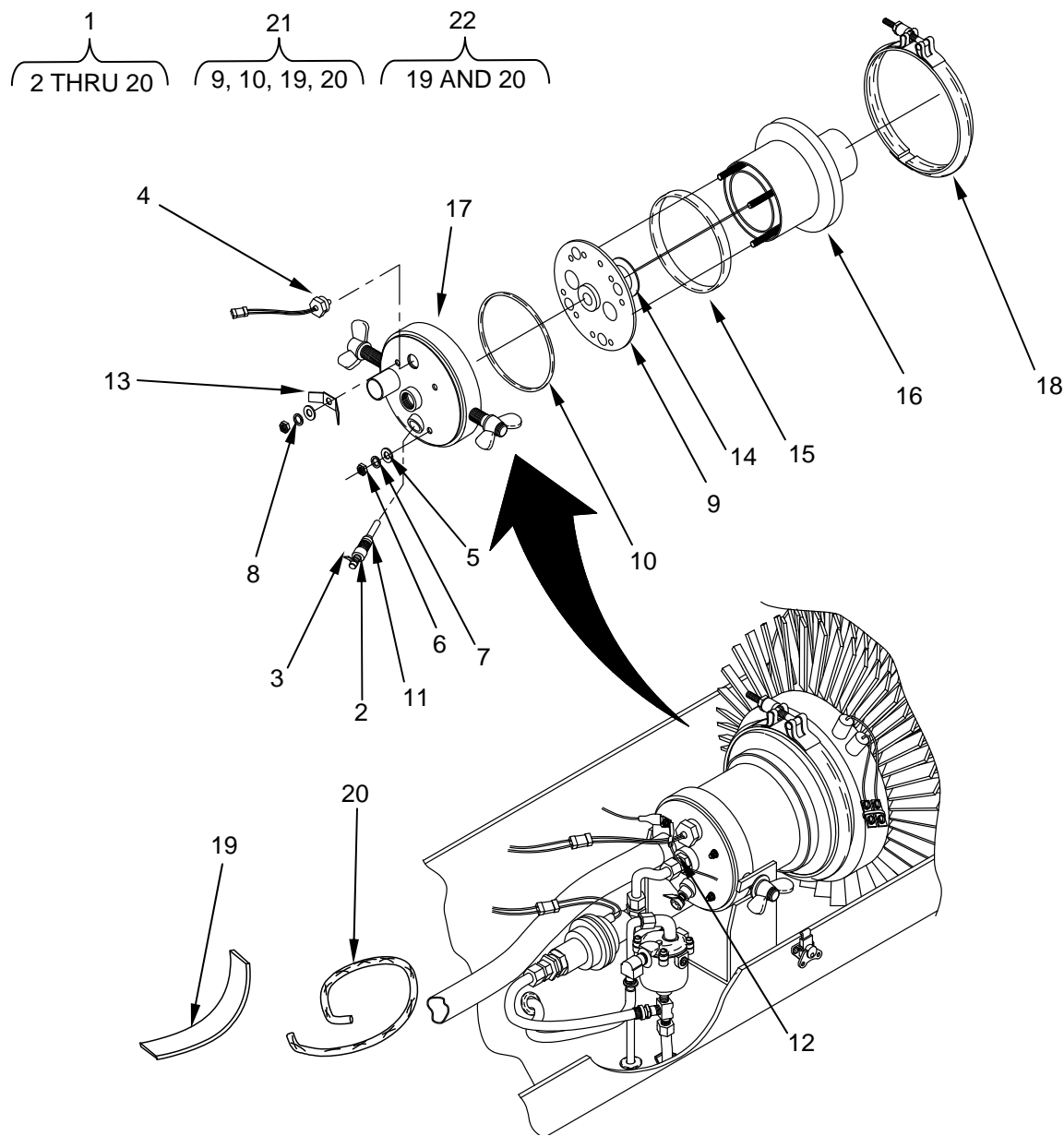

Figure 13. Burner Assembly.

(1)	(2)	(3)	(4)	(5)	(6)	(7)
ITEM NO	SMR CODE	NATIONAL STOCK NUMBER	CAGEC	PART NUMBER	DESCRIPTION AND USABLE ON CODE (UOC)	QTY
					GROUP 13 FIG. 13 BURNER ASSY	
1	PAOZZ	4520-01-493-2817	92878	60490	BURNER ASSY	1
2	PAOZZ	4520-01-493-2783	92878	60480	. GLOW PLUG	1
3	XDOZZ		92878	60469	. . TAB, QUICK CONNECT.....	1
4	PAOZZ	4520-01-493-2781	92878	60470	. SENSOR, FLAME.....	1
5	PAOZZ	5310-00-014-5850	96906	MS27183-42	. WASHER FLAT	2
6	PAOZZ	5310-00-934-9758	96906	MS35649-202	. NUT, HEX #10-24 THD	3
7	PAOZZ	5310-00-045-3296	96906	MS35338-43	. LOCKWASHER, SPLIT	3
8	PAOZZ	5310-00-596-7691	96906	MS35335-32	. LOCKWASHER, EXT. TOOTH.....	1
9	XAOZZ		92878	60472	. VAPORIZER ASSY	1
10	PAOZZ		92878	60458	. SEAL, O-RING	1
11	PAOZZ		92878	5-13-5642	. O-RING.....	1
12	XDOZZ		92878	60454	. CONNECTOR, 1/8 NPT	1
13	PAOZZ		92878	60455	. TAB, QD TWIN	1
14	PAOZZ	5310-01-103-1551	92878	8227133-01	. WASHER.....	2
15	PAOZZ		92878	5-13-5641	. GASKET, AIR PLATE.....	1
16	XDOZZ		92878	60498	. CHOKE TUBE AND FLANGE ASSY	1
17	XDOZZ		92878	60496	. BURNER COVER.....	1
18	PAOZZ	4520-01-493-2792	92878	5-13-5457	. CLAMP, V-BAND WITH NUT	1
19	PAOZZ	4520-01-493-2812	92878	5-13-5594	. SEAL, GRAPHITE RIBBON TAPE	1
20	PAOZZ	4520-01-493-2811	92878	5-13-5599	. ROPE, FIBERGLASS	1
21	PAOZZ	4520-01-533-0620	92878	5-13-5628	KIT, SHC BURNER MAINTENANCE	1
22	PAOZZ		92878	5-13-5570	KIT, GASKET	1
					END OF FIGURE	

UNIT MAINTENANCE

SPACE HEATER, CONVECTIVE

(NSN 4520-01-431-8927)

THERMOELECTRIC GENERATOR (TEG)

REPAIR PARTS LIST

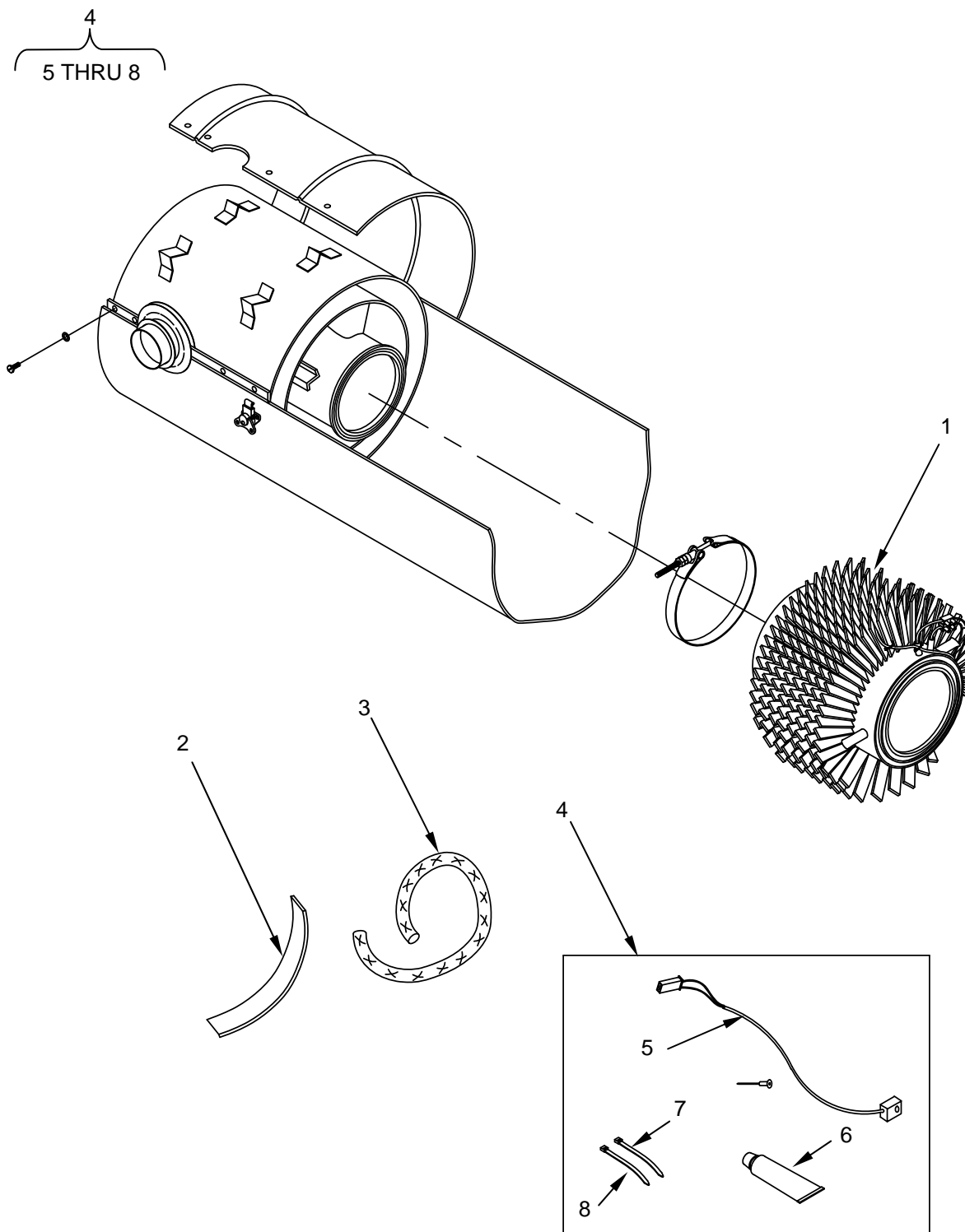

Figure 14. Thermoelectric Generator (TEG).

(1)	(2)	(3)	(4)	(5)	(6)	(7)
ITEM NO	SMR CODE	NATIONAL STOCK NUMBER	CAGEC	PART NUMBER	DESCRIPTION AND USABLE ON CODE (UOC)	QTY
					GROUP 14	
					FIG. 14 THERMOELECTRIC GENERATOR (TEG)	
1	PAOZZ	4520-01-493-2791	92878	5-13-5635	THERMOELECTRIC GENERATOR.....	1
2	PAOZZ	4520-01-493-2812	92878	5-13-5594	. SEAL, GRAPHITE RIBBON TAPE	2
3	PAOZZ	4520-01-493-2811	92878	5-13-5599	. ROPE, FIBERGLASS	2
4	PAOZZ	4520-01-533-0614	92878	5-13-5645	. KIT, SHC TEG SENSOR	1
5	KDOZZ		92878	5-13-5442	. . SENSOR, TEMPERATURE	1
6	KDOZZ		92878	10677	. . RTV, HIGH TEMPERATURE	1
7	KDOZZ		92878	170606	. . TIE WRAP	2
8	KDOZZ		92878	49049	. . TIE WRAP	6
					END OF FIGURE	

UNIT MAINTENANCE
SPACE HEATER, CONVECTIVE
(NSN 4520-01-431-8927)
HEAT EXCHANGER
REPAIR PARTS LIST

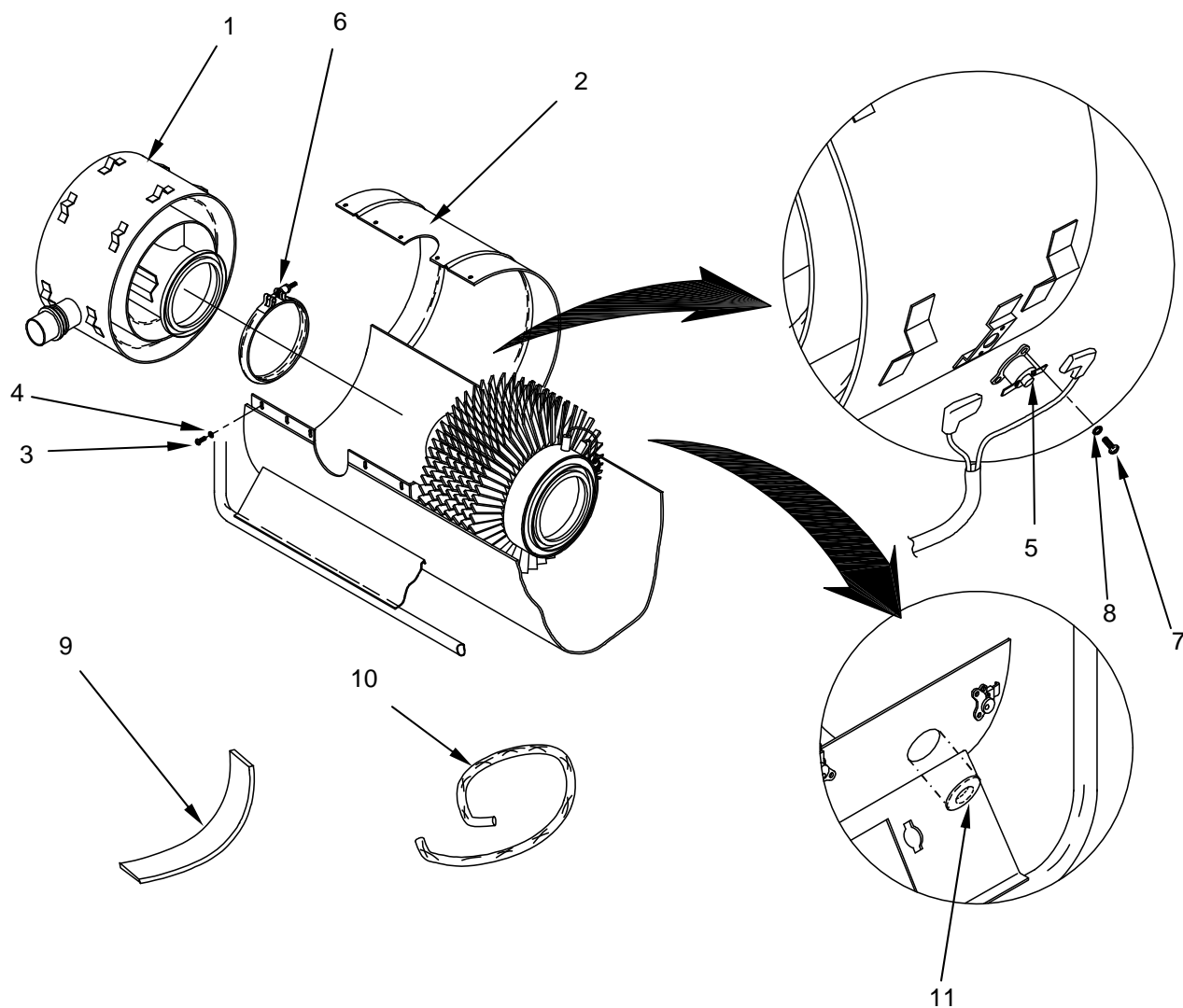

Figure 15. Heat Exchanger.

(1)	(2)	(3)	(4)	(5)	(6)	(7)
ITEM NO	SMR CODE	NATIONAL STOCK NUMBER	CAGEC	PART NUMBER	DESCRIPTION AND USABLE ON CODE (UOC)	QTY
					GROUP 15 FIG. 15 HEAT EXCHANGER	
1	PAOZZ	4520-01-493-2799	92878	5-13-5636	. HEAT EXCHANGER	1
2	PAOZZ		92878	5-13-5431	. COVER, WRAP	1
3	PAOZZ	5305-00-969-6914	96906	MS24617-10	. SCREW PHTF#6 X 3/8.....	5
4	PAOZZ	5310-00-209-0788	96906	MS35335-30	. WASHER LOCK #6 EXT	5
5	PAOZZ	4520-01-493-2802	92878	5-13-5520	. THERMOSTAT, MANUAL RESET	1
6	PAOZZ	4520-01-493-2792	92878	5-13-5457	. CLAMP, V-BAND WITH NUT	1
7	PAOZZ	5305-00-432-8027	96906	MS24617-9	. SCREW PHTF #6 X 1/4.....	2
8	PAOZZ	5310-00-209-0788	96906	MS35335-30	. WASHER LOCK #6 EXT	2
9	PAOZZ	4520-01-493-2812	92878	5-13-5594-16	. SEAL, GRAPHITE RIBBON TAPE	AR
10	PAOZZ	4520-01-493-2811	92878	5-13-5599-14.5	. ROPE, FIBERGLASS	1
11	PAOZZ	5325-00-809-8867	92878	5914	. GROMMET, RUBBER	1
					END OF FIGURE	

UNIT MAINTENANCE

SPACE HEATER, CONVECTIVE

(NSN 4520-01-431-8927)

AIR RETURN AND SUPPLY DUCTS WITH DEBRIS GRILL

REPAIR PARTS LIST

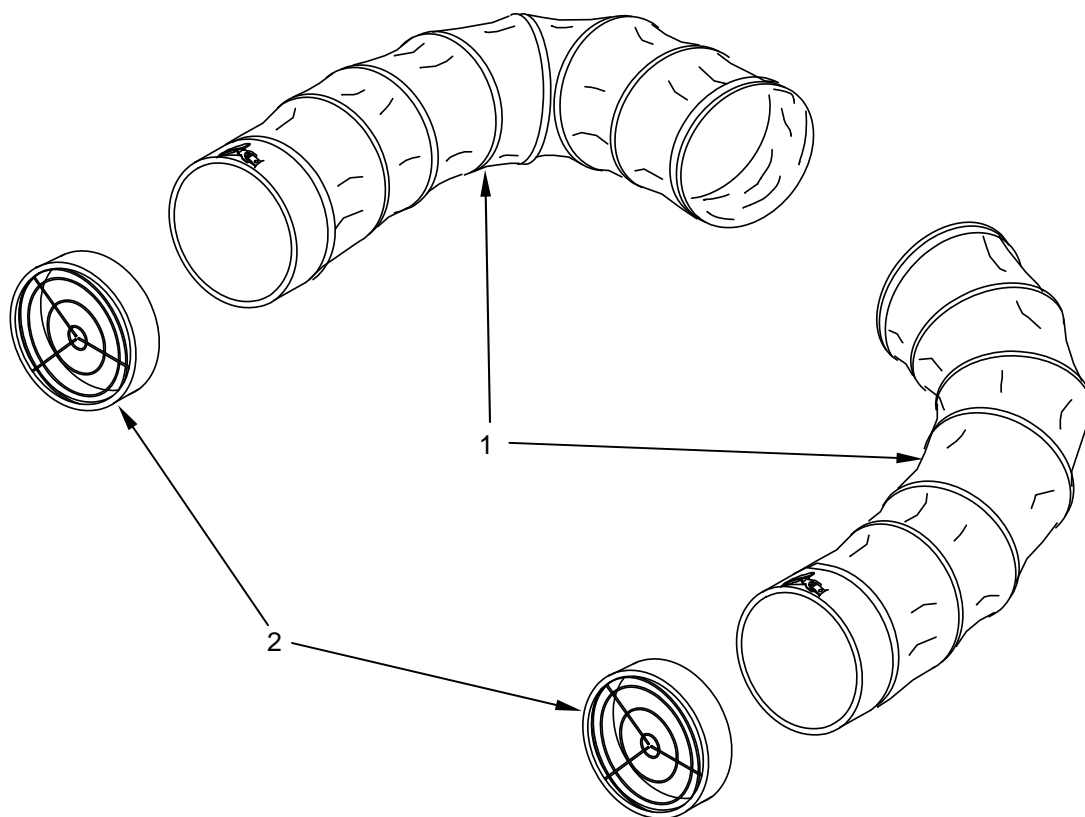

Figure 16. Air Return And Supply Ducts With Debris Grill.

(1)	(2)	(3)	(4)	(5)	(6)	(7)
ITEM NO	SMR CODE	NATIONAL STOCK NUMBER	CAGEC	PART NUMBER	DESCRIPTION AND USABLE ON CODE (UOC)	QTY
					GROUP 16	
					FIG. 16 AIR RETURN AND SUPPLY DUCTS WITH DEBRIS GRILL	
1	PAOZZ	4520-01-493-2863	92878	5-13-5429	. SHC HOSE HEATED AIR	2
2	PAOZZ	4520-01-493-2798	92878	5-13-5497	. FINGER GUARD ASSEMBLY	2
					END OF FIGURE	

UNIT MAINTENANCE

SPACE HEATER, CONVECTIVE

(NSN 4520-01-431-8927)

SPARES, TOOLS, AND ACCESSORIES

REPAIR PARTS LIST

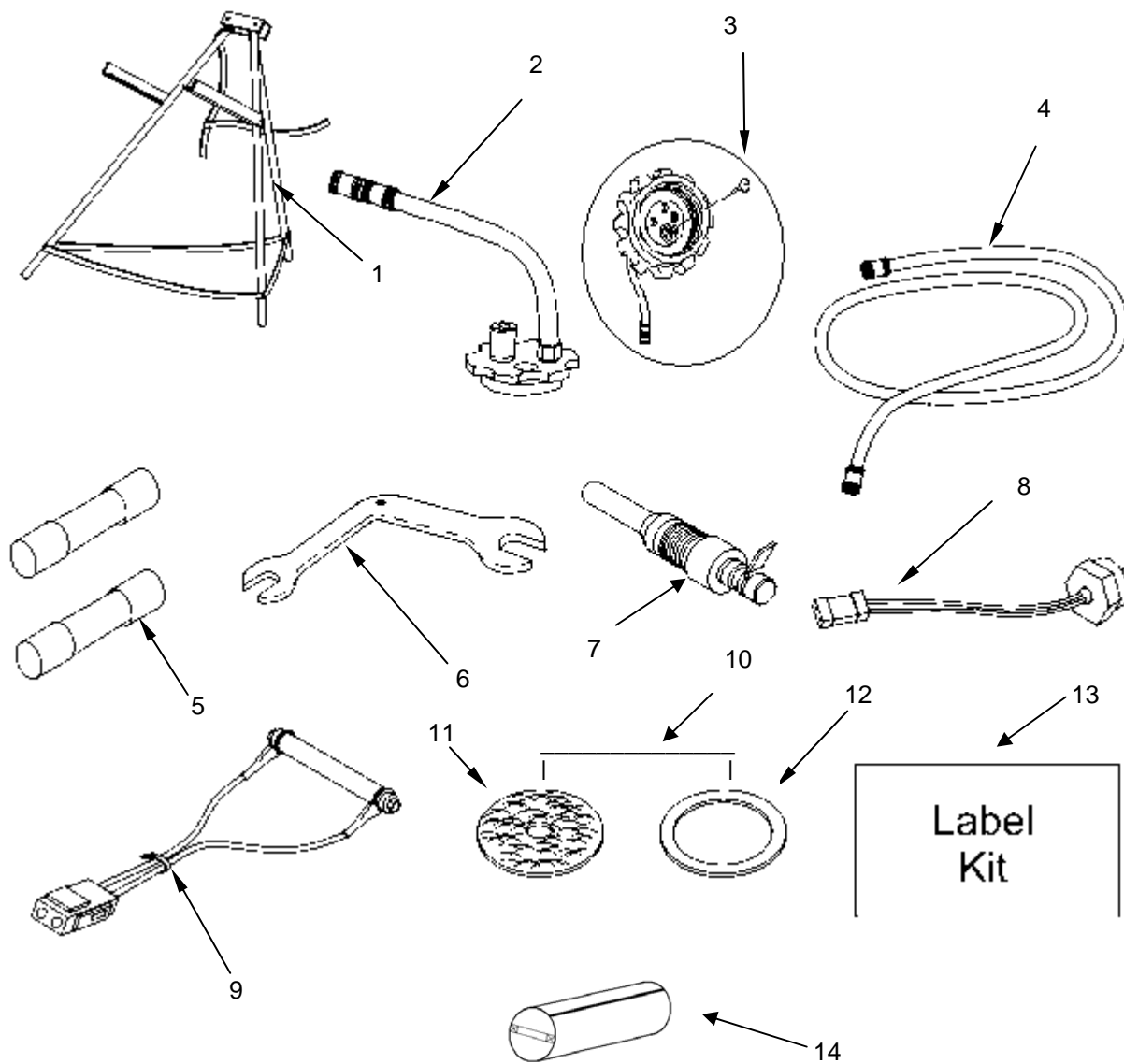

Figure 17. Spares, Tools, and Accessories.

(1)	(2)	(3)	(4)	(5)	(6)	(7)
ITEM NO	SMR CODE	NATIONAL STOCK NUMBER	CAGEC	PART NUMBER	DESCRIPTION AND USABLE ON CODE (UOC)	QTY
					GROUP 17 FIG. 17 SPARES, TOOLS, AND ACCESSORIES	
1	PAOZZ	4520-01-465-4430	92878	106369	. HEATER CAN STAND.....	1
2	PAOZZ	4520-01-469-5775	92878	171230	. CAP GRAVITY FEED ASSY.....	1
3	PAOZZ	4520-01-533-0627	92878	171236	. UMBRELLA VALVE	1
4	PAOZZ	4520-01-508-5743	92878	5-13-5630	. HOSE ASSEMBLY, SHC	1
5	PAOZZ	4520-01-493-2777	92878	46273	. FUSES.....	2
6	PAOZZ	4520-01-493-2797	92878	5-13-5477	. WRENCH.....	1
7	PAOZZ	4520-01-493-2783	92878	60480	. GLOW PLUG	1
8	PAOZZ	4520-01-493-2781	92878	60470	. FLAME SENSOR.....	1
9	PAOZZ	4520-01-493-2810	92878	5-13-5593	. BATTERY CHARGING ADAPTER	1
10	PAOZZ	4520-01-493-2816	92878	5-13-5638	. KIT, FUEL STRAINER	1
11	KFOZZ		92878	5-13-5531	. SCREEN, FUEL STRAINER.....	1
12	KFOZZ		92878	5-13-5530	. GASKET, FUEL STRAINER	1
13	PAOZZ	4520-01-493-2815	92878	5-13-5639	. LABEL KIT	1
14	PAOZZ	4520-01-506-2148	92878	53272	. BAG, SHC ACCESSORY	1
					END OF FIGURE	

SPACE HEATER, CONVECTIVE (SHC)
 NATIONAL STOCK NUMBER (NSN) INDEX

STOCK NUMBER	FIG.	ITEM	STOCK NUMBER	FIG.	ITEM
5310-00-014-5850	5	4	4520-01-493-2787	10	1
	13	5	4520-01-493-2788	8	1
5310-00-045-3296	13	7	4520-01-493-2790	3	7
5310-00-067-6357	7	4	4520-01-493-2791	14	1
5310-00-193-7577	4	3	4520-01-493-2792	13	21
	5	3		15	6
5310-00-209-0786	4	6	4520-01-493-2793	5	1
5310-00-209-0788	15	4	4520-01-493-2794	2	2
	15	8	4520-01-493-2795	7	1
5305-00-432-4171	4	2	4520-01-493-2796	2	1
	4	8	4520-01-493-2797	17	6
	5	2	4520-01-493-2798	16	2
5305-00-432-8027	15	7	4520-01-493-2799	15	1
5310-00-559-0070	4	9	4520-01-493-2800	1	1
5310-00-596-7691	11	3	4520-01-493-2801	9	1
	12	4	4520-01-493-2802	15	5
	13	8	4520-01-493-2803	9	2
5310-00-789-0398	11	4	4520-01-493-2804	6	1
5325-00-809-8867	15	11	4520-01-493-2805	4	7
5340-00-904-3705	12	2	4520-01-493-2806	4	1
5310-00-934-9758	13	6	4520-01-493-2807	1	2
5305-00-969-6914	15	3	4520-01-493-2808	4	10
5305-00-988-1728	4	5	4520-01-493-2810	17	9
5305-00-989-7434	7	3	4520-01-493-2811	13	23
5305-00-989-7435	11	2		14	3
	12	3		15	10
4730-01-206-8726	3	1	4520-01-493-2812	13	22
4520-01-465-4430	17	1		14	2
4520-01-469-5775	17	2		15	9
4520-01-492-9125	3	19	4520-01-493-2813	3	20
4520-01-493-2777	2	3	4520-01-493-2814	3	2
	17	5	4520-01-493-2815	17	13
4520-01-493-2778	12	1	4520-01-493-2816	17	10
4520-01-493-2779	4	4		3	15
4520-01-493-2780	4	11	4520-01-493-2817	13	1
4520-01-493-2781	13	4	4520-01-493-2862	11	1
	17	8	4520-01-493-2863	16	1
4520-01-493-2782	3	13	4520-01-506-2148	17	14
4520-01-493-2783	13	2	4520-01-508-5743	17	4
	17	7	4520-01-533-0614	14	4
4520-01-493-2784	12	5	4520-01-533-0620	13	25
4520-01-493-2785	3	14			
4520-01-493-2786	12	11			

SPACE HEATER, CONVECTIVE (SHC)
PART NUMBER INDEX

Part Number	Fig	Item	Part Number	Fig	Item
106369	17	1	5-13-5531	17	11
106534	3	4	5-13-5539	9	2
10677	14	6	5-13-5551	3	8
121830	3	3	5-13-5565	4	1
1321	3	11	5-13-5568	4	7
1366	3	18	5-13-5570	13	24
1591	12	7	5-13-5577	1	2
1601	12	10	5-13-5579	4	10
170606	14	7	5-13-5582	3	9
171230	17	2	5-13-5583	3	10
171236	17	3	5-13-5593	17	9
23824	15	11	5-13-5594	13	22
26370	12	6		14	2
3789	3	5		15	9
46273	2	3	5-13-5599	13	23
	17	5		14	3
4782401	3	12		15	10
48389	12	8	5-13-5616	3	14
48390	12	9	5-13-5628	13	25
49049	14	8	5-13-5630	17	4
49602	6	2	5-13-5634	8	1
5-13-5162	7	2	5-13-5635	14	1
5-13-5422	7	6	5-13-5636	15	1
5-13-5425	11	1	5-13-5637	3	2
5-13-5429	16	1	5-13-5638	3	15
5-13-5431	15	2		17	10
5-13-5435	10	1	5-13-5639	17	13
5-13-5439	3	7	5-13-5641	13	18
5-13-5442	14	5	5-13-5642	13	11
5-13-5457	13	21	5-13-5645	14	4
	15	6	52417-9	3	20
5-13-5461	5	1	53272	17	14
5-13-5468	2	2	5914	3	19
5-13-5469	2	1		15	11
5-13-5477	17	6	60442	13	12
5-13-5489	7	5	60443	13	13
5-13-5490	7	1	60444	13	14
5-13-5497	16	2	60454	13	15
5-13-5506	1	1	60455	13	16
5-13-5511	6	3	60458	13	10
5-13-5519	9	1	60468	4	4
5-13-5520	15	5	60469	13	3
5-13-5530	3	16	60470	13	4
	17	12		17	8
5-13-5531	3	17			

SPACE HEATER, CONVECTIVE (SHC)
PART NUMBER INDEX

Part Number	Fig	Item
60472	13	9
60477	12	11
60478	3	13
60480	13	2
	17	7
60481	12	1
60490	13	1
60496	13	20
60498	13	19
60499	12	5
7951286	11	4
8227133-01	13	17
HP2-4374	3	1
MS21333-82	12	2
MS24617-10	15	3
MS24617-9	15	7
MS27183-42	5	4
	13	5
MS35206-287	4	5
MS35207-263	7	3
MS35207-264	11	2
	12	3
MS35333-36	4	3
	5	3
MS35333-38	4	9
MS35335-19	4	6
MS35335-30	15	4
	15	8
MS35335-32	11	3
	12	4
	13	8
MS35338-43	13	7
MS35649-202	13	6
MS45904-69	7	4
MS51086-2	3	6
MS51861-36	4	2
	4	8
	5	2

**SPACE HEATER, CONVECTIVE (SHC)
COMPONENTS OF END ITEM (COEI) AND BASIC ISSUE ITEMS (BII) LISTS**

INTRODUCTION**Scope**

This work package lists the COEI and BII for the SHC and will help you inventory the items for safe and efficient operation of the equipment.

General

The COEI and BII Lists information is divided into the following lists:

Components of End Item (COEI). This listing is for information purposes only, and is not authority to requisition replacements. These items are part of the Space Heater, Convective. As part of the end item, these items must be with the end item whenever it is issued or transferred between property accounts. Items of COEI are removed and separately packaged for transportation or shipment only when necessary. Illustrations are furnished to help you find and identify the items.

Basic Issue Items (BII). These essential items are required to place the Space Heater, Convective in operation, operate it, and do emergency repairs. BII must be with the Space Heater, Convective during operation and when it is transferred between property accounts. This list is your authority to request/requisition them for replacement based on authorization of the end item by the TOE/MTOE. Illustrations are furnished to help you find and identify the items.

Explanation of Columns in the COEI list and BII List

Column (1) Illus Number. Gives you the number of the item illustrated.

Column (2) National Stock Number (NSN). Identifies the stock number of the item to be used for requisitioning purposes.

Column (3) Description, Part Number/(CAGEC). Identifies the Federal item name (in all capital letters) followed by a minimum description when needed. The stowage location of COEI and BII is also included in this column. The last line below the description is the part number and Commercial and Government Entity Code (CAGEC) (in parentheses).

Column (4) Usable on Code. When applicable, gives you a code if the item you need is not the same for different models of equipment.

Column (5) Unit of Issue (U/I). Indicates the physical measurement of count the item as issued per the National Stock Number shown in column (2).

Column (6) Qty Rqd. Indicates the quantity required.

COMPONENTS OF END ITEM LIST

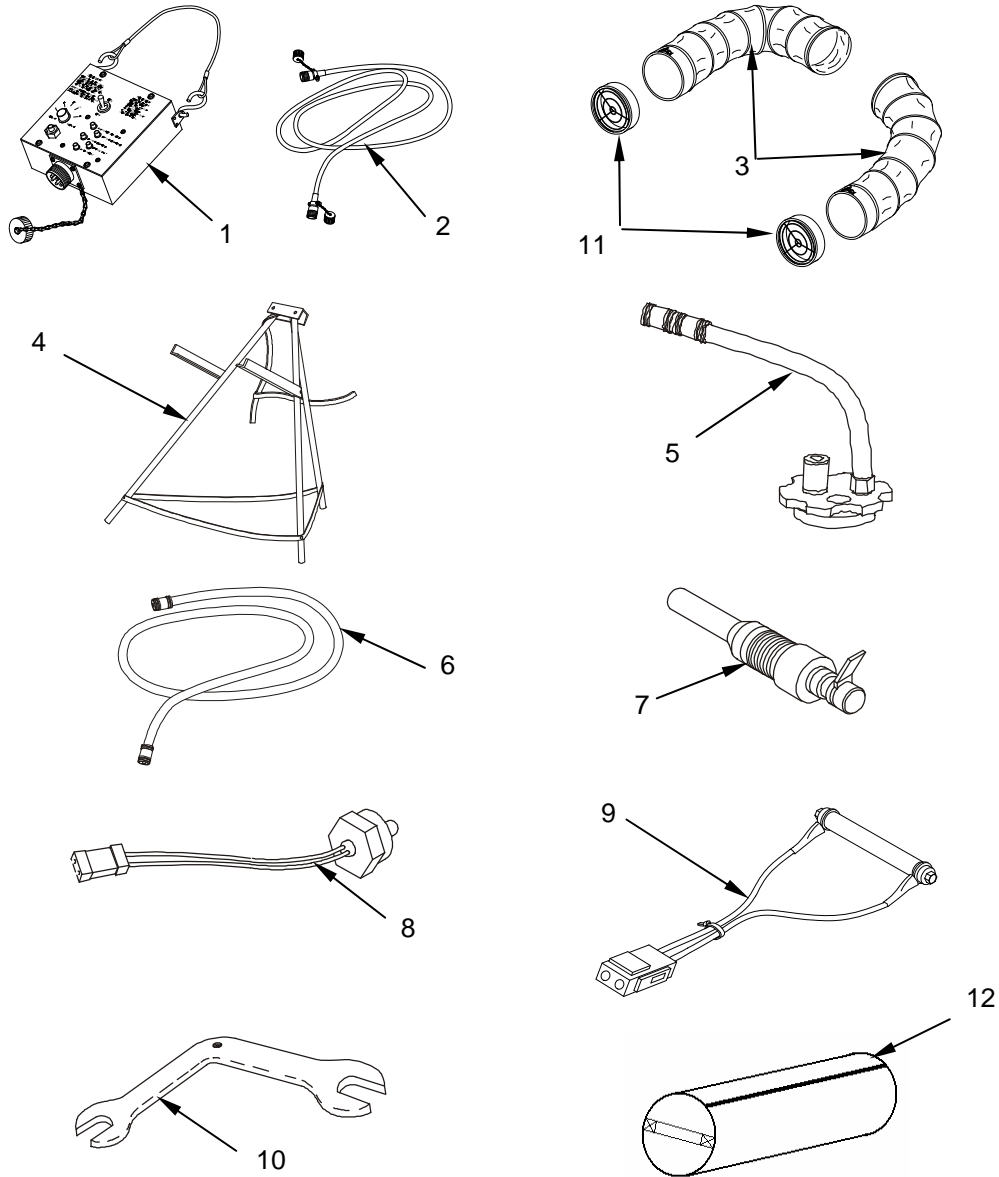

Table 1. Components of End Item for the Space Heater, Convective.

(1) ILLUS NUMBER	(2) NATIONAL STOCK NUMBER (NSN)	(3) DESCRIPTION, PART NUMBER/(CAGEC)	(4) USABLE ON CODE	(5) U/I	(6) QTY RQR
1	4520-01-493-2800	Controller Assembly, In-tent 5-13-5506 (92878)		EA	1
2	4520-01-493-2807	Controller Cable Assembly, In-tent 5-13-5577 (92878)		EA	1
3	4520-01-493-2863	SHC Hose Heated Air 5-13-5429 (92878)		EA	2
4	4520-01-465-4430	Stand Assembly, Fuel Can 106369 (92878)		EA	1
5	4520-01-469-5775	Adapter Kit, Gravity Feed 171230 (92878)		EA	1
6	4520-01-508-5743	SHC Hose Assy 5-13-5630 (92878)		EA	1
7	4520-01-493-2783	Glow Plug, 12 VDC 60480 (92878)		EA	1
8	4520-01-493-2781	Sensor, Flame 60470 (92878)		EA	1
9	4520-01-493-2810	Adapter, Battery Charger 5-13-5593 (92878)		EA	1
10	4520-01-493-2797	Wrench, 9/16 inch by 12 mm 5-13-5477 (92878)		EA	1
11	4520-01-493-2798	Debris Grill (Finger Guard Assembly) 5-13-5497 (92878)		EA	2
12	4520-01-506-2148	SHC Accessory Bag 53272 (92878)		EA	1

BASIC ISSUE ITEMS LIST

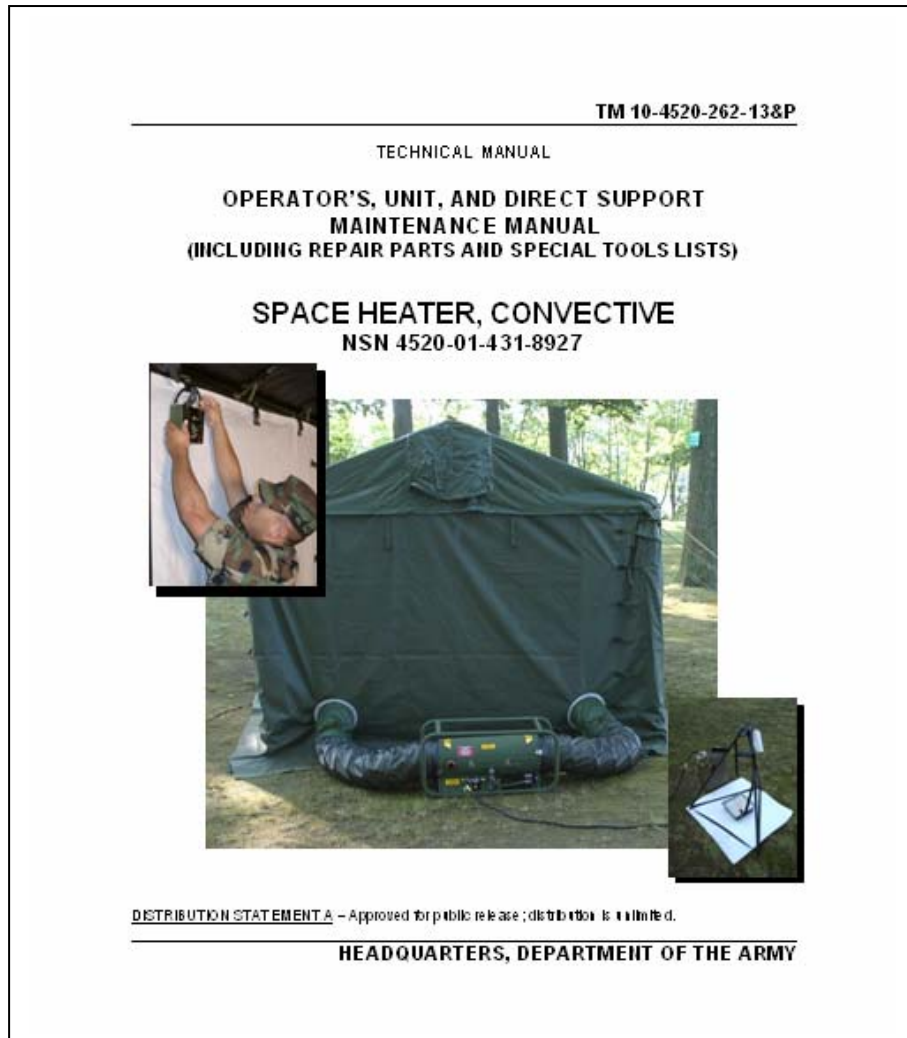

Table 2. Basic Issue Items for the Space Heater, Convective.

(1) ILLUS NUMBER	(2) NATIONAL STOCK NUMBER (NSN)	(3) DESCRIPTION (CAGEC) AND PART NUMBER	(4) USABLE ON CODE	(5) UNIT OF ISSUE U/I	(6) QTY RQR
1		Operator's, and Unit Maintenance Manual (including Repair Parts and Special Tools List) 5-13-5602 (92878)		EA	1

**SPACE HEATER, CONVECTIVE (SHC)
ADDITIONAL AUTHORIZATION LIST (AAL)**

INTRODUCTION

Scope

This work package lists additional items you are authorized for the support of the SHC.

General

This list identifies items that do not have to accompany the SHC and that do not have to be turned in with it. These items are all authorized to you by CTA, MTOE, TDA, or JTA.

Explanation of Columns in the AAL:

Column (1) National Stock Number (NSN). Identifies the stock number of the item to be used for requisitioning purposes.

Column (2) Description. Part Number/(CAGEC). Identifies the Federal item name (in all capital letters) followed by a minimum description when needed. The last line below the description is the part number and the Commercial and Government Entity Code (CAGEC) (in parentheses).

Column (3) Usable On Code. When applicable, gives you a code if the item you need is not the same for different models of equipment.

Column (4) U/I. Unit of Issue (U/I). Indicates the physical measurement or count of the item as issued per the National Stock Number shown in column (1).

Column (5) Qty Recm. Indicates the quantity recommended.

ADDITIONAL AUTHORIZED LIST ITEMS

Table 1. Additional Authorization List.

(1) NATIONAL STOCK NUMBER (NSN)	(2) DESCRIPTION, PART NUMBER/(CAGEC)	(3) USABLE ON CODE	(4) UNIT OF ISSUE U/I	(5) QTY RECM
7240-01-337-5268	CAN (DT), FUEL, MILITARY MIL-C-53109 (81349)	CVB	EA	1
7240-01-337-5269	CAN (CG), FUEL, MILITARY MIL-C-53109 (81349)	CVB	EA	1
4520-01-493-3215	KIT, TENT WALL MODIFICATION 5-13-5627 (92878)	CVB	EA	1
4520-01-533-0607	NATO CHARGING SYSTEM 53587 (92878)	CVB	EA	1
8145-01-547-2636	SHIPPING AND STORAGE CONTAINER 160175 (92878)	CVB	EA	1

**SPACE HEATER, CONVECTIVE (SHC)
EXPENDABLE AND DURABLE ITEMS LIST**

INTRODUCTION**Scope**

This work package lists expendable and durable items that you will need to operate and maintain the Space Heater Convective. This list is for information only and is not authority to requisition the listed items. These items are authorized to you by CTA 50-970, Expendable/Durable Items (Except Medical, Class V Repair Parts, and Heraldic Items), CTA 50-909, Field and Garrison Furnishings and Equipment or CTA 8-100, Army Medical Department Expendable/Durable Items.

EXPLANATION OF COLUMNS IN THE EXPENDABLE/DURABLE ITEMS LIST

Column (1) Item No. This number is assigned to the entry in the list and is referenced in the narrative instructions to identify the item (e.g., Use brake fluid (WP 0098 00, Item 5)).

Column (2) Level. This column identifies the lowest level of maintenance that requires the listed item (*include as applicable: C = Operator/Crew, O = Unit/AVUM, F = Direct Support/AVIM, H = General Support, D = Depot*).

Column (3) National Stock Number (NSN). This is the NSN assigned to the item which you can use to requisition it.

Column (4) Item Name, Description, Part Number/(CAGEC). This column provides the other information you need to identify the item. The last line below the description is the part number and the Commercial and Government Entity Code (CAGEC) (in parentheses).

Column (5) U/I. Unit of Issue (U/I). This code shows the physical measurement or count of an item, such as gallon, dozen, gross, etc.

(1) ITEM NO.	(2) LEVEL	(3) NATIONAL STOCK NUMBER (NSN)	(4) ITEM NAME, DESCRIPTION, PART NUMBER/(CAGEC)	(5) UNIT OF ISSUE (U/I)
1	O		Adhesive 1PBQ8 (81878)	TU
2	O	6810-00-286-5435	Alcohol, Isopropyl TT-I-735 (81348)	GL
3	O		Sealant, Thread 5-13-5357 (81337)	OZ
4	O	6850-01-265-3115	Lubricant, Silicone 03030 (10136)	BX
5	C	7920-00-205-1711	Rags, Wiping, Clean A-A-53 (58536)	BE
6	O	9905-00-537-8955	Tags, Marking MIL-T-12755 (81349)	BD
7	O	5970-00-681-8236	Tape, Electrical HH-I-553 (81348)	FT
8	O	7920-00-269-1259	Brush, Wire 20010 (76861)	EA
9	O	7510-01-481-9824	Tape, Duct P32W2A2-75-72 (06383)	RL
10	C,O	7930-01-363-8631	Mat, Petroleum Absorbent GOV106 (1JA49)	RL
11	O	5975-01-156-6648	Wrap, Tie PLT4H-L76 (06383)	EA
12	C,O	7930-01-316-6008	Tray, Petroleum Absorbent GOV103 (1JA49)	EA
13	O	5975-00-903-2284	Wrap, Tie (2 ea) MS3367-4-0 (81343)	EA
14	O	5975-00-984-6582	Wrap, Tie (6 ea) MS3367-1-0 (00779)	EA
15	O	7520-00-312-6124	Marker, Tube Type	DOZ

**SPACE HEATER, CONVECTIVE (SHC)
LUBRICATION INSTRUCTIONS**

GENERAL

Lubricate the heater with silicone lubricant in accordance with Table 1.



Table 1. Lubrication Instructions

COMPONENT	LUBRICANT/ AMOUNT	TEMPERATURE	INTERVAL	MAN HOUR
All fasteners (1)	Light coating of silicone lubricant (WP 0067, Table 1, Item 4)	All temperatures	As required	0.1

**SPACE HEATER CONVECTIVE (SHC)
TORQUE LIMITS**

GENERAL

This work package provides general torque limits for fasteners. Special torque values are indicated in the maintenance procedures for applicable components. The general torque values given in this work package shall be used when specific torque values are not indicated in the maintenance procedures.

TORQUE LIMITS

Torque limits are listed in Tables 1 and 2 for fasteners. Dry fasteners are defined as fasteners on which no lubricants are applied to the threads. Wet fasteners are defined as fasteners on which graphite, molydisulphide greases, or other extreme pressure lubricants are applied to the threads. Table 3 lists the minimum breakaway torque values for locknuts.

Table 1. General Torque Requirements for Dry Fasteners (#2 through #10)*

Bolt/Screw Size	Torque Requirements in in.-lb (N-m)						
	18-8 Stainless Steel	Brass	Silicon Bronze	Aluminum 2024-T4	316 Stainless Steel	Monel	Nylon**
2-56	2.5 (0.28)	2.0(0.23)	2.3 (0.26)	1.4 (0.16)	2.6 (0.29)	2.5 (0.28)	0.44 (0.5)
2-64	3.0 (0.34)	2.5 (0.28)	2.8 (0.32)	1.7 (0.19)	3.2 (0.36)	3.1 (0.35)	
3-48	3.9 (0.44)	3.2 (0.36)	3.6 (0.41)	2.1 (0.24)	4.0 (0.45)	4.0 (0.45)	
3-56	4.4 (0.50)	3.6 (0.48)	4.1 (0.46)	2.4 (0.27)	4.6 (0.52)	4.5 (0.51)	
4-40	5.2 (0.59)	4.3 (0.49)	4.8 (0.54)	2.9 (0.33)	5.5 (0.62)	5.3 (0.60)	1.19 (0.13)
4-48	6.6 (0.75)	5.4 (0.61)	6.1 (0.69)	3.6 (0.41)	6.9 (0.78)	6.7 (0.76)	
5-40	7.7 (0.87)	6.3 (0.71)	7.1 (0.80)	4.2 (0.48)	8.1 (0.92)	7.8 (0.88)	
5-44	9.4 (1.06)	7.7 (0.87)	8.7 (0.98)	5.1 (0.58)	9.8 (1.11)	9.6 (1.09)	
6-32	9.6 (1.09)	7.9 (0.89)	8.9 (1.01)	5.3 (0.60)	10.1 (1.14)	9.8 (1.11)	2.14 (0.24)
6-40	12.1 (1.37)	9.9 (1.12)	11.2 (1.27)	6.6 (0.75)	12.7 (1.44)	12.3 (1.39)	
8-32	19.8 (2.24)	16.2 (1.83)	18.4 (2.08)	10.8 (1.22)	20.7 (2.34)	20.2 (2.28)	4.3 (0.49)
8-36	22.0 (2.49)	18.0 (2.03)	20.4 (2.31)	12.0 (1.36)	23.0 (2.60)	22.4 (2.53)	
10-24	22.8 (2.58)	18.6(2.10)	21.2 (2.40)	13.8 (1.56)	23.8 (2.69)	25.9 (2.93)	6.61 (0.75)
10-32	31.7 (3.58)	25.9 (2.93)	29.3 (3.31)	19.2 (2.17)	33.1 (3.74)	34.9 (3.94)	8.2 (0.93)

* Torque given is for clean, dry threads. Reduce by 10% when lubricated.

** Nylon values only are breaking torque, rather than safe working torque.

Table 2. General Torque Requirements for Dry Fasteners (1/4-20 UNC through 1-1/2-12 UNF)*

Bolt/Screw Size	Torque Requirement in lb ft (N.m)			
	SAE Grade 1 or 2	SAE Grade 5	SAE Grade 6 or 7	SAE Grade 8
1/4-20 UNC	5 (7)	8 (11)	10 (14)	12 (16)
1/4-2SUNF	7 (8)	10 (14)	12 (16)	14 (19)
5/16-18 UNC	11 (15)	17 (23)	19 (26)	24 (33)
5/16-24 UNF	13 (18)	19 (26)	23 (31)	27 (37)
3/8-16 UNC	18 (24)	31 (42)	34 (46)	44 (60)
3/8-24 UNF	20 (27)	35 (47)	42 (57)	49 (66)
7/16-14 UNC	28 (38)	49 (66)	55 (75)	70 (95)
7/16-20 UNF	30 (41)	55 (75)	67 (91)	78 (106)
1/2-13UNC	39 (53)	75 (102)	85 (115)	105 (142)
1/2-2OUNF	41 (56)	85 (115)	102 (138)	120 (163)
9/16-12UNC	51 (69)	110 (149)	120 (163)	155 (210)
9/16-18UNF	55 (75)	120 (163)	145 (197)	170 (231)
5/8-11UNC	63 (85)	150 (203)	167 (226)	210 (285)
5/8-18 UNF	95 (129)	170 (231)	205 (278)	240 (325)
3/4-10 UNC	105 (142)	270 (366)	280 (380)	375 (509)
3/4-16 UNF	115 (156)	295 (400)	357 (484)	420 (570)
7/8-9 UNC	160 (217)	395 (536)	440 (597)	605 (820)
7/8-14 UNF	175 (237)	435 (590)	555 (753)	675 (915)
1-8 UNC	235 (319)	590 (800)	660 (895)	910 (1234)
1-14UNF	250 (339)	660 (865)	825 (1119)	999 (1342)
1-1/8-7 UNC	350 (475)	800 (1085)	1000 (1356)	1280 (1736)
1-1/8-12 UNF	400 (542)	880 (1193)	1050 (1424)	1440 (1953)
1-1/4-7 UNC	500 (678)	1080 (1464)	1325 (1797)	1820 (2468)
1-1/4-12UNF	550 (746)	1125 (1526)	1325 (1797)	1820 (2712)
1-3/8-6 UNC	660 (895)	1460 (1980)	1800 (2441)	2380 (3227)
1-3/8-12 UNF	740 (1003)	1680 (2278)	1960 (2658)	2720 (3688)
1-1/2-6UNC	870 (1180)	1940 (2631)	2913 (3950)	3160 (4285)
1-1/2-12 UNF	980 (1329)	2200 (2983)	3000 (4068)	3560 (4827)

* Torque given is for clean, dry threads. Reduce by 10% when lubricated.

NOTE

To determine breakaway torque, thread locknut onto screw or bolt until at least two threads stick out. Locknut shall not make contact with a mating part. Stop the locknut. Torque necessary to begin turning locknut again is the breakaway torque. Do not reuse locknuts that do not meet minimum breakaway torque.

Table 3. Locknut Breakaway Torque Values

Thread Size	Minimum Breakaway Torque	
	lb-in.	(N-m)
10-32	2.0	(0.23)
1/4-28	3.5	(0.40)
5/16-24	6.5	(0.73)
3/8-24	9.5	(1.07)
7/16-20	14.0	(1.58)
1/2-20	18.0	(2.03)
9/16-18	24.0	(2.71)
5/8-18	32.0	(3.62)
3/4-16	50.0	(5.65)
7/8-14	70.0	(7.91)
1-12	90.0	(10.17)
1-1/8-12	117.0	(13.22)

**SPACE HEATER CONVECTIVE (SHC)
MANDATORY REPLACEMENT PARTS LIST**

Table 1. Mandatory Replacement Parts

Item Number	Nomenclature	Part Number
1	Seal, graphite ribbon tape	5-13-5594-16

**SPACE HEATER CONVECTIVE (SHC)
GLOSSARY**

A

AUDIBLE TONE - A sound made within the control box assembly to alert the operator of the heater or tent occupants to the occurrence of a heater SYSTEM FAULT condition. This tone will repeat a number of times to indicate the applicable DIAGNOSTIC CODE. See the back of the control box assembly for a description of the applicable code.

B

BATTERY CHARGED - The thermoelectric generator (TEG) has completed charging the battery.

BATTERY CHARGING - The TEG is charging the battery.

BREATHABLE AIR - Air heated by the heater and introduced into the tent. Also known as heated air. This air is completely separated from the combustion air system of the heater and is free of any products of combustion resulting from heater operation.

D

DEBRIS GRILL - A device on the end of a duct used to prevent foreign objects from entering the duct or heater during heater operation. This item is not a louver and is not used to direct heated air.

DUCT - Term used to designate an item attached to either the heated air outlet or the breathable air inlet of the heater and through which heated (breathable) air passes.

G

GEL CELL - A type of rechargeable battery. Also known as starved electrolyte cell.

H

HEATER ON/ON-HOLD - Advisory light on control panel assembly.

HEATED AIR - Air heated by the heater and introduced into the tent. Also known as breathable air. This air is completely separated from the combustion air system of the heater and is free of any products of combustion resulting from heater operation.

L

LOWER-HIGHER KNOB - A knob on the control panel assembly used to control the temperature within the tent.

P

PIPE - Term used to designate an item attached to the combustion air inlet or outlet of the heater and through which combustion air passes.

POST-PURGE - A stage of heater operation that follows normal operation and precedes heater shutdown. During this stage of operation, the heater's fuel supply is shutoff and the fans run to clear combustion gases from the heater systems and cooldown heater components.

PREPURGE - A stage of heater operation that precedes normal operation. During this stage of operation, heater fans run to purge heater systems.

S

SETPOINT - A term used to indicate that the ambient temperature within the tent has reached or exceeded the setting number at which the LOWER/HIGHER knob is positioned. This condition is indicated by the illumination of the AT SETPOINT advisory light on the control panel assembly.

**SPACE HEATER CONVECTIVE (SHC)
ALPHABETICAL INDEX**

A

Accessories and Heater, Packaging of	0042 00
Accessories, Heater	0062 00
Adjustments, Checks, and Services, Initial	0005 00
Administrative Storage	0042 00
Assembly and Preparation for Use	0005 00

B

Battery Assembly	0018 00
Battery Pack, Compartment Cover Assemblies for	0018 00
Biological Decontamination Procedures	0007 00
Blower Support Assembly, Removing	0027 00
Burner Assembly	0037 00
Burner-to-Thermoelectric Generator (TEG) Flange Clamp	0037 00

C

Capabilities, Features, and Equipment Characteristics	0001 00
Care, Handling, and Safety	0001 00
Chain and Dust Covers	0026 00
Checks and Services (PMCS):	
Operator Preventive Maintenance	0010 00
Unit Preventive Maintenance	0014 00
Checks and Services, Initial Adjustments	0005 00
Chemical Decontamination Procedures	0007 00
Circuit Board, Power	0024 00
Circuit Description	0003 00
Cleaning Agents	0015 00
Cold, Operation in Extreme	0007 00
Combustion Air Blower, Compartment Cover Assemblies for	0027 00
Combustion Air Inlet Box	0029 00
Combustion Air Inlet Pipe	0029 00
Combustion Air System, External	0027 00
Combustion Blower Assembly, Repairing	0027 00
Compartment Cover Assemblies for Battery Pack	0018 00
Compartment Cover Assemblies for Combustion Air Blower	0027 00
Compartment Cover Assemblies for Heater Control Assembly	0022 00
Components, Description and Location of Major	0002 00
Control Assembly (Front View), Tent	0002 00
Control Cable, Remote	0017 00
Controller, Electronic	0022 00
Controls and Indicators	0004 00
Corrosion Prevention and Control (CPC)	0001 00
Cover Assemblies for Battery Pack, Compartment	0018 00
Cover Assemblies for Combustion Air Blower, Compartment	0027 00
Cover Assemblies for Heater Control Assembly, Compartment	0022 00

INDEX

D

Data, Equipment	0002 00
Decals:	
and Information Plates	0004 00
Decontamination Procedures, Interim Nuclear, Biological, and Chemical (NBC)	0007 00
Definitions, Leakage:	
for Operator PMCS	0010 00
for Unit PMCS	0014 00
Description:	
and Location of Major Components	0002 00
and Use of Operator's Controls and Indicators.....	0004 00
Circuit	0003 00
Functional.....	0001 00
Destruction of Army Materiel to Prevent Enemy Use	0043 00
Disassembly, Thermoelectric Generator (TEG) and Heat Exchanger.....	0038 00
Disconnecting Burner From TEG	0037 00
Drain Valve and Fuel Vent Hose Assembly	0037 00
Dust Covers and Chain	0026 00
Dust or Sand, Operation in Extreme	0007 00

E

Elbow and Quick Disconnect Fitting	0019 00
Electrical/Electronic System, Internal.....	0024 00
Electronic Controller.....	0024 00
Equipment:	
Characteristics, Capabilities, and Features	0001 00
Data.....	0002 00
Improvement Recommendations (EIR), Reporting.....	0001 00
External Combustion Air System	0027 00
External Fuel System	0020 00

F

Features, Equipment Characteristics, and Capabilities	0001 00
Flame Sensor	0012 00
Flange Clamp, Burner-to-Thermoelectric Generator (TEG)	0037 00
Fuel Control Assembly	0036 00
Fuel Hose Assembly	0021 00
Fuel Selection Information	0001 00
Fuel Solenoid Valve Assembly	0020 00
Fuel System, Internal	0035 00
Fuel System, External	0020 00
Fuel Vent Hose Assembly and Drain Valve.....	0037 00

G

Generator (TEG), Thermoelectric, and Heat Exchanger	0002 00
Glow Plug.....	0013 00

INDEX

H

Handling, Safety, and Care	0001 00
Heated Air Blower Assembly.....	0033 00
Heated Air System	0033 00
Heater:	
Resetting the	0004 00
Typical Tent.....	0001 00
Heater Accessories	0002 00
Heater and Accessories, Packaging of	0042 00
Heater Assembly:	
Information Plates	0004 00
Information Plate Locations	0004 00
Setup Inside of Tent	0005 00
Setup Outside of Tent	0005 00
Major Components of the.....	0002 00
Heater Control Assembly, Compartment Cover Assemblies for.....	0022 00
Heater Controls and Indicators	0004 00
Heat Exchanger and Thermoelectric Generator (TEG)	0002 00
Heat Exchanger Assembly.....	0039 00
Housing Assembly:	
Lower.....	0040 00
Upper.....	0030 00
Humidity, Extreme, or Rain, Operation in	0007 00

I

Identification Plate.....	0004 00
Ignition Pack Assembly	0025 00
Improvement Recommendations (EIR), Reporting Equipment.....	0001 00
Indicators and Controls	0004 00
Information Plate Locations.....	0004 00
Information Plates and Decals	0004 00
Initial Adjustments, Checks, and Services	0005 00
Inspecting Internal Electrical/Electronic System	0022 00
Inspection, Burner-to-Thermoelectric Generator (TEG) Flange Clamp.....	0039 00
Inspection, Heat Exchanger Assembly	0039 00
Inspection, Internal Electrical/Electronic System	0022 00
Inspection, Thermoelectric Generator (TEG) and Heat Exchanger.....	0039 00
Installation Dust Covers and Chain.....	0026 00
Installation, Burner Assembly	0039 00
Installation, Burner-to-Thermoelectric Generator (TEG) Flange Clamp	0039 00
Installation, Chain and Dust Covers.....	0026 00
Installation, Combustion Air Inlet Pipe	0029 00
Installation, Compartment Cover Assemblies for Battery Pack	0018 00
Installation, External Combustion Air System	0027 00
Installation, External Fuel System.....	0020 00
Installation, Flame Sensor.....	0012 00
Installation, Glow Plug.....	0013 00

INDEX
I-Continued

Identification Plate	
Installation, Heated Air System	0033 00
Installation, Internal Electrical/Electronic System	0025 00
Installation, Internal Fuel System	0035 00
Installation, Lower Housing Assembly	0040 00
Installation, Thermoelectric Generator	0038 00
Installation, Lower Housing Assembly (TEG) and Heat Exchanger	0040 00
Interim Nuclear, Biological, and Chemical (NBC) Decontamination Procedures	0007 00
Internal Electrical/Electronic System	0025 00
Internal Fuel System	0035 00

L

Leakage Definitions:	
for Operator PMCS	0010 00
for Unit PMCS	0014 00
Location and Description of Major Components	0002 00
Locations, Information Plate	0004 00
Lower Housing Assembly	0040 00

M

Maintenance Checks and Services (PMCS):	
Operator Preventive	0010 00
Unit Preventive	0014 00
Maintenance Forms, Records, and Reports	0001 00
Maintenance Procedures:	
Operator	0011 00
Unit	0015 00
Major Components:	
Description and Location of	0002 00
of the Heater Assembly	0002 00
Manual Reset	0004 00

N

Nomenclature:	
Cross-Reference	0001 00
Names, and Designations, Official	0001 00
Normal Operation, Stopping, and Starting	0006 00
Nuclear Decontamination Procedures	0007 00

O

Official Nomenclature, Names, and Designations	0001 00
Onboard Spares/Tools	0002 00
Operating Procedures	0006 00

INDEX
O-Continued

Operation:

- in Extreme Cold..... 0007 00
- in Extreme Dust or Sand..... 0007 00
- in High Winds..... 0007 00
- in Rain or Extreme Humidity..... 0007 00
- Principles of..... 0007 00
- Under Unusual Conditions..... 0007 00
- Under Usual Conditions..... 0006 00

Operator Maintenance Procedures..... 0011 00

Operator Preventive Maintenance Checks and Services (PMCS)..... 0010 00

Operator's Controls and Indicators,
Use and Description of..... 0004 00

P

PMCS Procedures..... 0010 00

PMCS Table..... 0010 00

Packaging of Heater and Accessories..... 0042 00

Packaging..... 0042 00

Plate:

- Identification..... 0004 00

Power Circuit Board..... 0024 00

Preparation:

- and Assembly for Use..... 0005 00
- for Storage or Shipment..... 0042 00

Preservation..... 0042 00

Preventive Maintenance Checks and:
Services (PMCS)..... 0010 00

- Operator..... 0010 00
- Unit..... 0014 00

Principles of Operation..... 0003 00

Q

Quality Assurance (QA)..... 0001 00

Quick Disconnect Fitting and Elbow..... 0019 00

R

Rain or Extreme Humidity, Operation in Receptacle Wiring, External Connector..... 0007 00

Records, and Reports, Maintenance Forms..... 0001 00

Remote Control Cable Testing..... 0017 00

Removal From Service..... 0042 00

Removal, Burner Assembly..... 0037 00

Removal, Burner-to-Thermoelectric Generator (TEG) Flange Clamp..... 0037 00

Removal, Chain and Dust Covers..... 0026 00

Removal, Combustion Air Blower..... 0027 00

INDEX

R-Continued

Removal, Combustion Air Inlet Pipe	0029 00
Removal, Compartment Cover Assemblies for Battery Pack	0018 00
Removal, Dust Covers and Chain.....	0026 00
Removal, External Combustion Air System	0027 00
Removal, External Fuel System.....	0020 00
Removal, Flame Sensor.....	0012 00
Removal, Glow Plug	0013 00
Removal, Heated Air System.....	0033 00
Removal, Heater Control Assembly.....	0022 00
Removal, Internal Electrical/Electronic System	0024 00
Removal, Internal Fuel System.....	0035 00
Removal, Thermoelectric Generator (TEG) and Heat Exchanger	0038 00
Removing Blower Support Assembly.....	0027 00
Repair Battery Assembly.....	0018 00
Repair Combustion Air Blower	0027 00
Repair Combustion Blower Assembly.....	0027 00
Repair Compartment Cover Assemblies for Battery Pack.....	0018 00
Repair Electronic Controller	0024 00
Repair External Combustion Air System.....	0028 00
Repair External Fuel System	0020 00
Repair Heater Control Assembly	0024 00
Repair Internal Electrical/Electronic System.....	0024 00
Replace Battery Assembly.....	0018 00
Replace Electronic Controller.....	0024 00
Replacing External Combustion Air System	0028 00
Replacing Fuel Cap Assembly.....	0019 00
Replacing Internal Electrical/Electronic System.....	0024 00
Replacing Upper Housing Assembly	0030 00
Reporting Equipment Improvement Recommendations (EIR).....	0001 00
Reports, Maintenance Forms, and Records	0001 00
Reset, Manual	0004 00
Resetting the Heater	0004 00
Rubber Foot	0002 00

S

Safety, Care, and Handling	0001 00
Sand or Dust, Operation in Extreme	0007 00
Scope	0001 00
Sensor, Flame	0012 00
Services, Initial Adjustments, Checks, and	0005 00
Setup of Heater Assembly:	
Inside of Tent	0005 00
Outside of Tent.....	0005 00
Shipment, Preparation for	0042 00
Spares/Tools, Onboard	0002 00
Special Tools List	0062 00
Starting, Normal Operation, and Stopping	0006 00

INDEX

S-Continued

Stopping, Starting, and Normal Operation	0006 00
Storage:	
Administrative	0042 00
Preparation for	0042 00

T

Tent Control Assembly (Front View)	0002 00
Testing External Combustion Air System	0027 00
Testing Heated Air System	0033 00
Testing Internal Electrical/Electronic System.....	0024 00
Testing Internal Fuel System	0035 00
Testing Remote Control Cable.....	0017 00
Testing Thermoelectric Generator (TEG) and Heat Exchanger	0038 00
Thermoelectric Generator (TEG) and Heat Exchanger	0038 00
Tools/Spares, Onboard	0002 00
Troubleshooting	0009 00

U

Unit Maintenance Procedures.....	0015 00
Unit Preventive Maintenance Checks and Services (PMCS)	0014 00
Unit Troubleshooting	0009 01
Unusual Conditions, Operation Under	0007 00
Upper Housing Assembly.....	0030 00
Use and Description of Operator's Controls and Indicators.....	0004 00
Usual Conditions, Operation Under	0006 00

W

Winds, Operation in High	0007 00
Wiring Harness and Wiring Harness Grommet.....	0023 00

By Order of the Secretary of the Army:

Official:



JOEL B. HUDSON

*Administrative Assistant to the
Secretary of the Army*

0128506

ERIC K. SHINSEKI
*General, United States Army
Chief of Staff*

DISTRIBUTION:

To be distributed in accordance with Initial Distribution Number (IDN) 256698, requirements for TM 10-4520-262-12&P.

These are the instructions for sending an electronic 2028

The following format must be used if submitting an electronic 2028. The subject line must be exactly the same and all fields must be included; however only the following fields are mandatory: 1, 3, 4, 5, 6, 7, 8, 9, 10, 13, 15, 16, 17, and 27.

From: "Whomever" whomever@avma27.army.mil

To: TACOMLCMC.DAForm2028@us.army.mil

Subject: DA Form 2028

1. **From:** Joe Smith
2. **Unit:** home
3. **Address:** 4300 Park
4. **City:** Hometown
5. **St:** MO
6. **Zip:** 77777
7. **Date Sent:** 19-OCT-93
8. **Pub no:** 55-2840-229-23
9. **Pub Title:** TM
10. **PublicationDate:** 04-JUL-85
11. **Change Number:** 7
12. **Submitter Rank:** MSG
13. **Submitter FName:** Joe
14. **Submitter MName:**T
15. **Submitter LName:** Smith
16. **Submitter Phone:** (123) 123-1234
17. **Problem:** 1
18. **Page:** 2
19. **Paragraph:** 3
20. **Line:** 4
21. **NSN:** 5
22. **Reference:** 6
23. **Figure:** 7
24. **Table:** 8
25. **Item:** 9
26. **Total:** 123
27. **Text:**

This is the text for the problem below line 27.

RECOMMENDED CHANGES TO PUBLICATIONS AND BLANK FORMS For use of this form, see AR 25-30; the proponent agency is ODISC4.						Use Part II (reverse) for Repair Parts and Special Tool Lists (RPSTL) and Supply Catalogs/Supply Manuals (SC/SM).	DATE 21 October 2003
TO: (Forward to proponent of publication or form) (Include ZIP Code) TACOM Life Cycle Management Command ATTN: AMSTA-LC-LMPP/TECH PUBS 1 Rock Island Arsenal Rock Island, IL 61299-7630						FROM: (Activity and location) (Include ZIP Code) <i>PFC Jane Doe</i> <i>CO A 3rd Engineer BR</i> <i>Ft. Leonardwood, MO 63108</i>	
PART I – ALL PUBLICATIONS (EXCEPT RPSTL AND SC/SM) AND BLANK FORMS							
PUBLICATION/FORM NUMBER TM 10-1670-296-23&P				DATE 30 October 2002	TITLE Unit Manual for Ancillary Equipment for Low Velocity Air Drop Systems		
ITEM NO.	PAGE NO.	PARA-GRAPH	LINE NO. *	FIGURE NO.	TABLE NO.	RECOMMENDED CHANGES AND REASON <i>(Provide exact wording of recommended changes, if possible).</i>	
	0036 00-2				1	<i>In table 1, Sewing Machine Code Symbols, the second sewing machine code symbol should be MD ZZ not MD 22.</i> <i>Change the manual to show Sewing Machine, Industrial: Zig-Zag; 308 stitch; medium-duty; NSN 3530-01-181-1421 as a MD ZZ code symbol.</i>	
<i>*Reference to line numbers within the paragraph or subparagraph.</i>							
TYPED NAME, GRADE OR TITLE Jane Doe, PFC				TELEPHONE EXCHANGE/AUTOVON, PLUS EXTENSION 508-233-4141		SIGNATURE Jane Doe <i>Jane Doe</i>	

TO: <i>(Forward direct to addressee listed in publication)</i> TACOM Life Cycle Management Command ATTN: AMSTA-LC-LMPP/TECH PUBS 1 Rock Island Arsenal Rock Island, IL 61299-7630	FROM: <i>(Activity and location) (Include ZIP Code)</i> <i>PFC Jane Doe</i> <i>CO A 3rd Engineer BR</i> <i>Ft. Leonardwood, MO 63108</i>	DATE 21 October 2003
--	---	--------------------------------

PART II – REPAIR PARTS AND SPECIAL TOOL LISTS AND SUPPLY CATALOGS/SUPPLY MANUALS

PUBLICATION NUMBER TM 10-1670-296-23&P	DATE 30 October 2002	TITLE Unit Manual for Ancillary Equipment for Low Velocity Air Drop Systems
--	--------------------------------	---

PAGE NO.	COLM NO.	LINE NO.	NATIONAL STOCK NUMBER	REFERENCE NO.	FIGURE NO.	ITEM NO.	TOTAL NO. OF MAJOR ITEMS SUPPORTED	RECOMMENDED ACTION
0066 00-1					4			<i>Callout 16 in figure 4 is pointed to a <u>D-Ring</u>. In the Repair Parts List key for figure 4, item 16 is called a <u>Snap Hook</u>. Please correct one or the other.</i>

PART III – REMARKS *(Any general remarks or recommendations, or suggestions for improvement of publications and blank forms. Additional blank sheets may be used if more space is needed.)*

--	--	--

TYPED NAME, GRADE OR TITLE	TELEPHONE EXCHANGE/AUTOVON, PLUS EXTENSION	SIGNATURE
----------------------------	--	-----------

RECOMMENDED CHANGES TO PUBLICATIONS AND BLANK FORMS For use of this form, see AR 25-30; the proponent agency is ODISC4.						Use Part II (<i>reverse</i>) for Repair Parts and Special Tool Lists (RPSTL) and Supply Catalogs/Supply Manuals (SC/SM).	DATE
TO: (<i>Forward to proponent of publication or form</i>) (<i>Include ZIP Code</i>) TACOM Life Cycle Management Command ATTN: AMSTA-LC-LMPP/TECH PUBS 1 Rock Island Arsenal, Rock Island, IL 61299-7630						FROM: (<i>Activity and location</i>) (<i>Include ZIP Code</i>)	
PART I – ALL PUBLICATIONS (EXCEPT RPSTL AND SC/SM) AND BLANK FORMS							
PUBLICATION/FORM NUMBER TM 10-4520-262-12&P						DATE 1 August 2008	TITLE Operator's and Unit Maintenance Manual (Including Repair Parts and Special Tools List) for Space Heater, Convective, (SHC 35K)
ITEM NO.	PAGE NO.	PARA-GRAPH	LINE NO. *	FIGURE NO.	TABLE NO.	RECOMMENDED CHANGES AND REASON (<i>Provide exact wording of recommended changes, if possible.</i>)	
<i>*Reference to line numbers within the paragraph or subparagraph.</i>							
TYPED NAME, GRADE OR TITLE				TELEPHONE EXCHANGE/AUTOVON, PLUS EXTENSION		SIGNATURE	

TO: <i>(Forward direct to addressee listed in publication)</i> TACOM Life Cycle Management Command ATTN: AMSTA-LC-LMPP/TECH PUBS 1 Rock Island Arsenal, Rock Island, IL 61299-7630	FROM: <i>(Activity and location) (Include ZIP Code)</i>	DATE
---	---	------

PART II – REPAIR PARTS AND SPECIAL TOOL LISTS AND SUPPLY CATALOGS/SUPPLY MANUALS

PUBLICATION NUMBER TM 10-4520-262-12&P	DATE 1 August 2008	TITLE Operator's and Unit Maintenance Manual (Including Repair Parts and Special Tools List) for Space Heater, Convective, (SHC 35K)
---	-----------------------	---

PAGE NO.	COLM NO.	LINE NO.	NATIONAL STOCK NUMBER	REFERENCE NO.	FIGURE NO.	ITEM NO.	TOTAL NO. OF MAJOR ITEMS SUPPORTED	RECOMMENDED ACTION

PART III – REMARKS *(Any general remarks or recommendations, or suggestions for improvement of publications and blank forms. Additional blank sheets may be used if more space is needed.)*

TYPED NAME, GRADE OR TITLE	TELEPHONE EXCHANGE/AUTOVON, PLUS EXTENSION	SIGNATURE
----------------------------	--	-----------

RECOMMENDED CHANGES TO PUBLICATIONS AND BLANK FORMS For use of this form, see AR 25-30; the proponent agency is ODISC4.						Use Part II (<i>reverse</i>) for Repair Parts and Special Tool Lists (RPSTL) and Supply Catalogs/Supply Manuals (SC/SM).	DATE
TO: (<i>Forward to proponent of publication or form</i>) (<i>Include ZIP Code</i>) TACOM Life Cycle Management Command ATTN: AMSTA-LC-LMPP/TECH PUBS 1 Rock Island Arsenal, Rock Island, IL 61299-7630						FROM: (<i>Activity and location</i>) (<i>Include ZIP Code</i>)	
PART I – ALL PUBLICATIONS (EXCEPT RPSTL AND SC/SM) AND BLANK FORMS							
PUBLICATION/FORM NUMBER TM 10-4520-262-12&P						DATE 1 August 2008	TITLE Operator's and Unit Maintenance Manual (Including Repair Parts and Special Tools List) for Space Heater, Convective, (SHC 35K)
ITEM NO.	PAGE NO.	PARA-GRAPH	LINE NO. *	FIGURE NO.	TABLE NO.	RECOMMENDED CHANGES AND REASON <i>(Provide exact wording of recommended changes, if possible).</i>	
<i>*Reference to line numbers within the paragraph or subparagraph.</i>							
TYPED NAME, GRADE OR TITLE				TELEPHONE EXCHANGE/AUTOVON, PLUS EXTENSION		SIGNATURE	

TO: <i>(Forward direct to addressee listed in publication)</i> TACOM Life Cycle Management Command ATTN: AMSTA-LC-LMPP/TECH PUBS 1 Rock Island Arsenal, Rock Island, IL 61299-7630	FROM: <i>(Activity and location) (Include ZIP Code)</i>	DATE
---	---	------

PART II – REPAIR PARTS AND SPECIAL TOOL LISTS AND SUPPLY CATALOGS/SUPPLY MANUALS

PUBLICATION NUMBER TM 10-4520-262-12&P	DATE 1 August 2008	TITLE Operator's and Unit Maintenance Manual (Including Repair Parts and Special Tools List) for Space Heater, Convective, (SHC 35K)
---	-----------------------	---

PAGE NO.	COLM NO.	LINE NO.	NATIONAL STOCK NUMBER	REFERENCE NO.	FIGURE NO.	ITEM NO.	TOTAL NO. OF MAJOR ITEMS SUPPORTED	RECOMMENDED ACTION

PART III – REMARKS *(Any general remarks or recommendations, or suggestions for improvement of publications and blank forms. Additional blank sheets may be used if more space is needed.)*

TYPED NAME, GRADE OR TITLE	TELEPHONE EXCHANGE/AUTOVON, PLUS EXTENSION	SIGNATURE
----------------------------	--	-----------

RECOMMENDED CHANGES TO PUBLICATIONS AND BLANK FORMS For use of this form, see AR 25-30; the proponent agency is ODISC4.						Use Part II (<i>reverse</i>) for Repair Parts and Special Tool Lists (RPSTL) and Supply Catalogs/Supply Manuals (SC/SM).	DATE
TO: (<i>Forward to proponent of publication or form</i>) (<i>Include ZIP Code</i>) TACOM Life Cycle Management Command ATTN: AMSTA-LC-LMPP/TECH PUBS 1 Rock Island Arsenal, Rock Island, IL 61299-7630						FROM: (<i>Activity and location</i>) (<i>Include ZIP Code</i>)	
PART I – ALL PUBLICATIONS (EXCEPT RPSTL AND SC/SM) AND BLANK FORMS							
PUBLICATION/FORM NUMBER TM 10-4520-262-12&P						DATE 1 August 2008	TITLE Operator's and Unit Maintenance Manual (Including Repair Parts and Special Tools List) for Space Heater, Convective, (SHC 35K)
ITEM NO.	PAGE NO.	PARA-GRAPH	LINE NO. *	FIGURE NO.	TABLE NO.	RECOMMENDED CHANGES AND REASON <i>(Provide exact wording of recommended changes, if possible).</i>	
<i>*Reference to line numbers within the paragraph or subparagraph.</i>							
TYPED NAME, GRADE OR TITLE				TELEPHONE EXCHANGE/AUTOVON, PLUS EXTENSION		SIGNATURE	

TO: <i>(Forward direct to addressee listed in publication)</i> TACOM Life Cycle Management Command ATTN: AMSTA-LC-LMPP/TECH PUBS 1 Rock Island Arsenal, Rock Island, IL 61299-7630	FROM: <i>(Activity and location) (Include ZIP Code)</i>	DATE
--	--	-------------

PART II – REPAIR PARTS AND SPECIAL TOOL LISTS AND SUPPLY CATALOGS/SUPPLY MANUALS

PUBLICATION NUMBER TM 10-4520-262-12&P	DATE 1 August 2008	TITLE Operator's and Unit Maintenance Manual (Including Repair Parts and Special Tools List) for Space Heater, Convective, (SHC 35K)
--	------------------------------	--

PAGE NO.	COLM NO.	LINE NO.	NATIONAL STOCK NUMBER	REFERENCE NO.	FIGURE NO.	ITEM NO.	TOTAL NO. OF MAJOR ITEMS SUPPORTED	RECOMMENDED ACTION

PART III – REMARKS *(Any general remarks or recommendations, or suggestions for improvement of publications and blank forms. Additional blank sheets may be used if more space is needed.)*

TYPED NAME, GRADE OR TITLE	TELEPHONE EXCHANGE/AUTOVON, PLUS EXTENSION	SIGNATURE
-----------------------------------	---	------------------

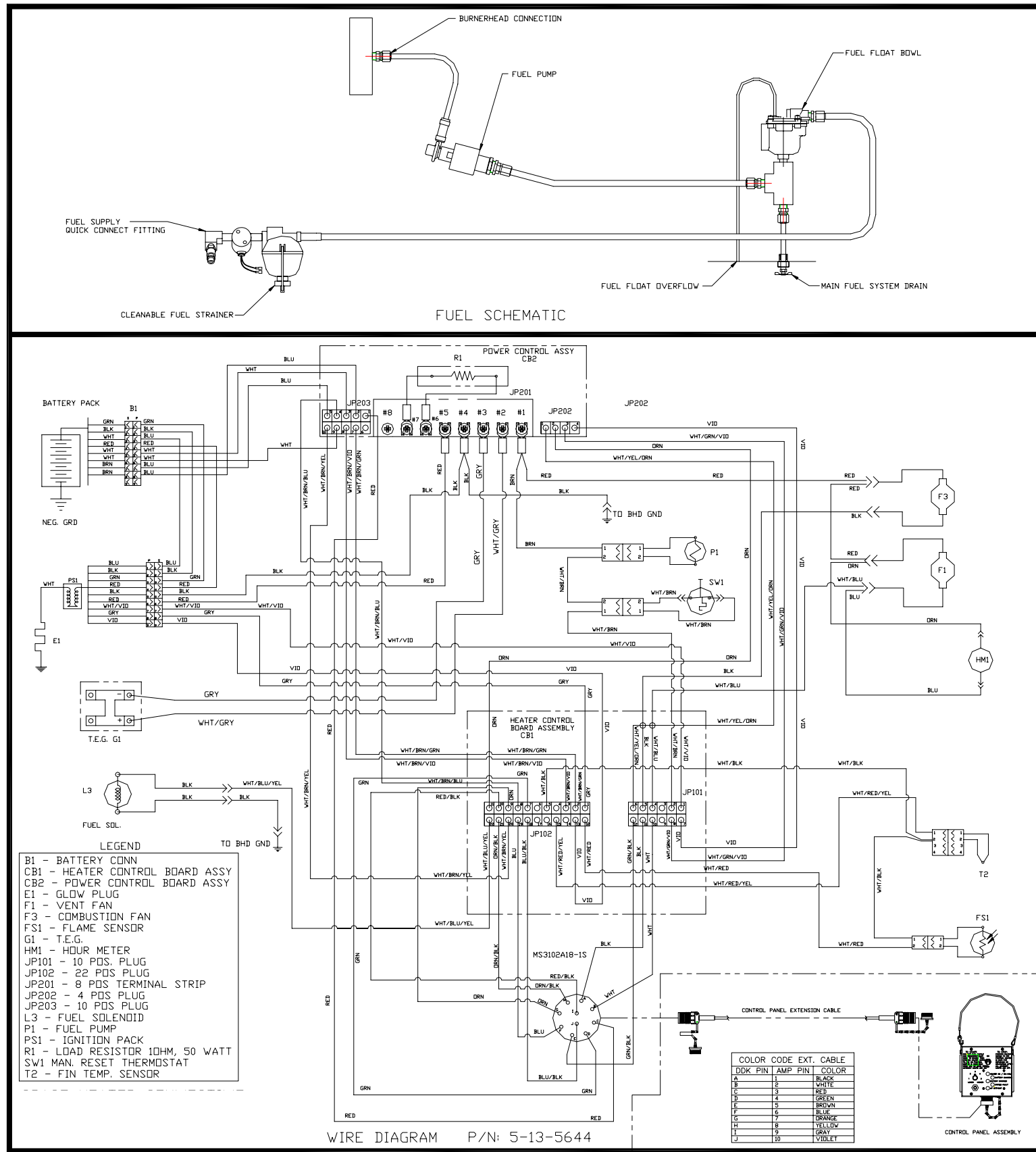

Figure 1. PC Board Wiring Diagram.

The Metric System and Equivalents

Linear Measure

1 centimeter = 10 millimeters = .39 inch
 1 decimeter = 10 centimeters = 3.94 inches
 1 meter = 10 decimeters = 39.37 inches
 1 dekameter = 10 meters = 32.8 feet
 1 hectometer = 10 dekameters = 328.08 feet
 1 kilometer = 10 hectometers = 3,280.8 feet

Weights

1 centigram = 10 milligrams = .15 grain
 1 decigram = 10 centigrams = 1.54 grains
 1 gram = 10 decigrams = .035 ounce
 1 dekagram = 10 grams = .35 ounce
 1 hectogram = 10 dekagrams = 3.52 ounces
 1 kilogram = 10 hectograms = 2.2 pounds
 1 quintal = 100 kilograms = 220.46 pounds
 1 metric ton = 10 quintals = 1.1 short tons

Liquid Measure

1 centiliter = 10 milliliters = .34 fl. ounce
 1 deciliter = 10 centiliters = 3.38 fl. ounces
 1 liter = 10 deciliters = 33.81 fl. ounces
 1 dekaliter = 10 liters = 2.64 gallons
 1 hectoliter = 10 dekaliters = 26.42 gallons
 1 kiloliter = 10 hectoliters = 264.18 gallons

Square Measure

1 sq. centimeter = 100 sq. millimeters = .155 sq. inch
 1 sq. decimeter = 100 sq. centimeters = 15.5 sq. inches
 1 sq. meter (centare) = 100 sq. decimeters = 10.76 sq. feet
 1 sq. dekameter (are) = 100 sq. meters = 1,076.4 sq. feet
 1 sq. hectometer (hectare) = 100 sq. dekameters = 2.47 acres
 1 sq. kilometer = 100 sq. hectometers = .386 sq. mile

Cubic Measure

1 cu. centimeter = 1000 cu. millimeters = .06 cu. inch
 1 cu. decimeter = 1000 cu. centimeters = 61.02 cu. inches
 1 cu. meter = 1000 cu. decimeters = 35.31 feet

Approximate Conversion Factors

<i>To change</i>	<i>To</i>	<i>Multiply by</i>	<i>To change</i>	<i>To</i>	<i>Multiply by</i>
inches	centimeters	2.540	ounce-inches	newton-meters	.007062
feet	meters	.305	centimeters	inches	.394
yards	meters	.914	meters	feet	3.280
miles	kilometers	1.609	meters	yards	1.094
square inches	square centimeters	6.451	kilometers	miles	.621
square feet	square meters	.093	square centimeters	square inches	.155
square yards	square meters	.836	square meters	square feet	10.764
square miles	square kilometers	2.590	square meters	square yards	1.196
acres	square hectometers	.405	square kilometers	square miles	.386
cubic feet	cubic meters	.028	square hectometers	acres	2.471
cubic yards	cubic meters	.765	cubic meters	cubic feet	35.315
fluid ounces	milliliters	29.573	cubic meters	cubic yards	1.308
pints	liters	.473	milliliters	fluid ounces	.034
quarts	liters	.946	liters	pints	2.113
gallons	liters	3.785	liters	quarts	1.057
ounces	grams	28.349	liters	gallons	.264
pounds	kilograms	.454	grams	ounces	.035
short tons	metric tons	.907	kilograms	pounds	2.205
pound-feet	newton-meters	1.356	metric tons	short tons	1.102
pound-inches	newton-meters	.11296			

Temperature (Exact)

_F	Fahrenheit temperature	5/9 (after subtracting 32)	Celsius temperature	_C
----	---------------------------	-------------------------------	------------------------	----

PIN: 079343-000